



*An Online PDH Course
brought to you by
CEDengineering.com*

Liquid Process Piping Systems

Course No: M12-001

Credit: 12 PDH

Elie Tawil, P.E., LEED AP



Continuing Education and Development, Inc.

P: (877) 322-5800
info@cedengineering.com

This course was adapted from the United States Army of Corps of Engineers (USACE), Publication No. EM 1110-1-4008, Chapters 3 to 12 of the "Liquid Process Piping" engineering manual, which is in the public domain.

Chapters 1 and 2 as well as Appendices A through D are provided for reference only.

**Engineering and Design
LIQUID PROCESS PIPING**

1. This change to EM 1110-1-4008, 5 May 1999, updates example problems in Chapter 4 and adds references to Appendix A.

2. Substitute attached pages as shown below:

Chapter	Remove pages	Insert pages
4	4-14-4-21	4-14-4-20
Appendix A	A-6-A-7	A-6-A-7

3. File this change sheet in front of this publication for reference purposes.

FOR THE COMMANDER:

JOSEPH SCHROEDEL
Colonel, Corps of Engineers
Chief of Staff

Errata Sheet

No. 1

Engineering and Design

Liquid Process Piping

EM 1110-1-4008

5 May 1999

Reference to MSS SP-119 on page A-6, paragraph A-1 is in error. The title of the document is incorrect. Page A-6, paragraph A-1: The title for MSS SP-119 should be as follows: Belled End Socket Welding Fittings, Stainless Steel and Copper -Nickel.

Engineering and Design
LIQUID PROCESS PIPING

1. The purpose of this manual is to provide information for the design of liquid process piping.
2. Applicability. This manual applies to all HQUSACE elements and all USACE Commands having responsibility for the design of unit processes for treatment of liquids.
3. Distribution Restriction. Approved for public release; distribution is unlimited.
4. References. References are provided in Appendix A.
5. Scope. This manual is to be used in the selection of piping systems and materials for chemical and physical unit processes. Process piping systems include pipe and appurtenances used to transport fluids. Separate guidance has been provided for plumbing, potable water, sewage, storm drainage, fuel and lubricant systems.
6. Discussion. This manual includes criteria for the design of component parts and assemblies of liquid process piping systems. Compliance with these criteria requires that fundamental design principles are followed. Modification or additions to existing systems solely for the purpose of meeting criteria in this manual are not authorized.

FOR THE COMMANDER:

4 Appendices
(See Table of Contents)

ALBERT J. GENETTI, JR.
Major General, U. S. Army
Chief of Staff

**Engineering and Design
LIQUID PROCESS PIPING**

TABLE OF CONTENTS

SUBJECT	PARAGRAPH	PAGE	SUBJECT	PARAGRAPH	PAGE
Chapter 1					
Introduction					
Purpose	1-1	1-1	Design Pressure	4-3	4-9
Applicability	1-2	1-1	Piping Supports for Metallic Piping Systems	4-4	4-9
References	1-3	1-1	Joining	4-5	4-12
Distribution	1-4	1-1	Thermal Expansion	4-6	4-12
Scope	1-5	1-1	Ductile Iron	4-7	4-17
Metrics	1-6	1-1	Carbon Steel	4-8	4-17
Brand Names	1-7	1-1	Stainless Steel	4-9	4-18
Accompanying Guidance			Nickel and Nickel Alloys	4-10	4-19
Specification	1-8	1-1	Aluminum	4-11	4-20
Manual Organization	1-9	1-3	Copper	4-12	4-21
Chapter 2					
Design Strategy					
Design Analyses	2-1	2-1	Chapter 5		
Specifications	2-2	2-1	Plastic Piping Systems		
Drawings	2-3	2-1	General	5-1	5-1
Bases of Design	2-4	2-2	Polyvinyl Chloride (PVC)	5-2	5-9
Loading Conditions	2-5	2-7	Polytetrafluoroethylene (PTFE)	5-3	5-9
Piping Layout	2-6	2-10	Acrylonitrile-Butadiene-Styrene (ABS)	5-4	5-9
Chapter 3					
General Piping Design					
Materials of Construction	3-1	3-1	Chlorinated Polyvinyl Chloride (CPVC)	5-5	5-10
Design Pressure	3-2	3-2	Polyethylene (PE)	5-6	5-10
Sizing	3-3	3-7	Polypropylene (PP)	5-7	5-10
Stress Analysis	3-4	3-17	Polyvinylidene Fluoride (PVDF)	5-8	5-10
Flange, Gaskets and Bolting			Chapter 6		
Materials	3-5	3-19	Rubber and Elastomer Piping Systems		
Pipe Identification	3-6	3-23	General	6-1	6-1
Piping Supports	3-7	3-23	Design Factors	6-2	6-1
Testing and Flushing	3-8	3-29	Sizing	6-3	6-4
Chapter 4					
Metallic Piping Systems					
General	4-1	4-1	Piping Support and Burial	6-4	6-5
Corrosion	4-2	4-1	Fluoroelastomer	6-5	6-5
			Isobutylene Isoprene	6-6	6-5
			Acrylonitrile Butadiene	6-7	6-5
			Polychloroprene	6-8	6-5
			Natural Rubber	6-9	6-5

TABLE OF CONTENTS - CONTINUED

SUBJECT	PARAGRAPH	PAGE	SUBJECT	PARAGRAPH	PAGE
Chapter 7 Thermoset Piping Systems			Chapter 12 Corrosion Protection		
General	7-1	7-1	Corrosion Protection	12-1	12-1
Reinforced Epoxies	7-2	7-5	Cathodic Protection	12-2	12-1
Reinforced Polyesters	7-3	7-5	Isolation Joints	12-3	12-2
Reinforced Vinyl Esters	7-4	7-6	Protective Coatings	12-4	12-4
Reinforced Furans	7-5	7-6			
Chapter 8 Double Containment Piping Systems			Appendix A References		
General	8-1	8-1	Appendix B Fluid/Material Matrix		
Piping System Sizing	8-2	8-6	Appendix C Design Example		
Double Containment Piping System Testing	8-3	8-7	Appendix D Index		
Leak Detection Systems	8-4	8-8			
Chapter 9 Lined Piping Systems					
General	9-1	9-1			
Plastic Lined Piping Systems	9-2	9-3			
Other Lined Piping Systems	9-3	9-8			
Chapter 10 Valves					
General	10-1	10-1			
Valve Types	10-2	10-9			
Valve Sizing and Selection	10-3	10-13			
Valve Schedule	10-4	10-20			
Chapter 11 Ancillary Equipment					
Flexible Couplings	11-1	11-1			
Air and Vacuum Relief	11-2	11-1			
Drains	11-3	11-5			
Sample Ports	11-4	11-5			
Pressure Relief Devices	11-5	11-5			
Backflow Prevention	11-6	11-7			
Static Mixers	11-7	11-8			
Expansion Joints	11-8	11-9			
Piping Insulation	11-9	11-10			
Heat Tracing	11-10	11-12			

Chapter 1 Introduction

1-1. Purpose

This United States Army Corps of Engineers (USACE) Engineer Manual (EM) 1110-1-4008 provides information for the design of liquid process piping systems.

1-2. Applicability

Liquid process piping systems include all pipe and appurtenances which are used to convey liquids to, from and between pumping, storage and treatment units and which are not integral to any unit (i.e., piping that is furnished as a part of the unit). Plumbing is covered by TM 5-810-5, potable water piping is covered by TI 814-03, sewage piping is covered by TI 814-10, storm drainage, and fuel and lubricant supply piping are excluded.

1-3. References

Required and related references are listed in Appendix A.

1-4. Distribution

This manual is approved for public release; distribution is unlimited.

1-5. Scope

This manual includes criteria for the design of component parts and assemblies of liquid process piping systems. Compliance with these criteria requires only that fundamental design principles be followed. Materials and practices not prohibited by this manual or its basic references should also be considered. Where special conditions and problems are not specifically addressed in this manual, acceptable industry standards should be followed. Modifications or additions to existing systems solely for the purpose of meeting criteria in this manual are not authorized.

a. Cathodic Protection

All underground ferrous piping will be cathodically protected. TM 5-811-7 (Army) and MIL-HDBK-

1004/10 (Air Force) contain additional guidance pertaining to cathodic protection of underground pipelines.

1-6. Metrics

Both the International System of Units (SI) (the Modernized Metric System) and the Inch-Pound (IP) ("English") system of measurement are used in this manual. Pipe and appurtenances are provided in standard dimensions, either in International Organization for Standardization (ISO) sizes which are SI based, or in American National Standards Institute (ANSI) sizes which are IP based. Table 1-1 compares the standard sizes of the measurement systems. Standard sizes under the two systems are close, but not equivalent. A similar table is included in the Tri-Service CADD Details Library.

a. SI Design Requirement

In accordance with ER 1110-1-4, where feasible, all project designs for new facilities after 1 January 1994 must be developed using the SI system of measurement. The USACE metric conversion has been closely coordinated with that of the construction industry. Where the industry has committed to a "hard" metric product, USACE must specify and use that product in its designs. Where the industry is as yet undecided, IP products should be used with a "soft" conversion when design efficiency or architectural treatments are not compromised. The limited availability of some metric products may require additional investigation, may result in more complex procurement, and may alter scheduling during construction.

1-7. Brand Names

The citation in this manual of brand names of commercially available products does not constitute official endorsement or approval of the use of such products.

1-8. Accompanying Guidance Specification

This manual is intended to be used in conjunction with CEGS 15200, Liquid Process Piping.

Table 1-1 Standard Pipe Dimensions					
ANSI		ISO			
Nominal Pipe Size (in)	Actual D _o (in)	Nominal Pipe Size		Actual D _o	
		(mm)	(in)	(mm)	(in)
1/8	0.405	6	(0.236)	10	(0.394)
1/4	0.540	8	(0.315)	12	(0.472)
3/8	0.675	10	(0.394)	16	(0.630)
1/2	0.840	15	(0.591)	20	(0.787)
3/4	1.050	20	(0.787)	25	(0.984)
1	1.315	25	(0.984)	32	(1.260)
1 1/4	1.660	32	(1.260)	40	(1.575)
1 1/2	1.900	40	(1.575)	50	(1.969)
2	2.375	50	(1.969)	63	(2.480)
2 1/2	2.875	65	(2.559)	75	(2.953)
3	3.500	80	(3.150)	90	(3.543)
4	4.500	100	(3.937)	110	(4.331)
5	5.563	125	(4.921)	140	(5.512)
6	6.625	150	(5.906)	160	(6.299)
8	8.625	200	(7.874)	225	(8.858)
10	10.75	250	(9.843)	280	(11.024)
12	12.75	300	(11.81)	315	(12.402)
14	14.00	350	(13.78)	356	(14.00)
16	16.00	400	(15.75)	407	(16.00)
18	18.00	450	(17.72)	457	(18.00)
20	20.00	500	(19.69)	508	(20.00)
--	--	550	(21.65)	559	(22.00)
24	24.00	600	(23.62)	610	(24.02)
--	--	650	(25.59)	660	(25.98)
28	28.00	700	(27.56)	711	(27.99)
30	30.00	750	(29.53)	762	(30.00)
32	32.00	800	(31.50)	813	(32.00)
--	--	850	(33.46)	864	(34.02)
36	36.00	900	(35.43)	914	(35.98)
40	40.00	1000	(39.37)	1016	(40.00)
--	--	1050	(41.34)	1067	(42.00)
44	44.00	1100	(43.31)	1118	(44.00)
48	48.00	1200	(47.24)	1219	(48.00)
52	52.00	1300	(51.18)	1321	(52.00)
56	56.00	1400	(55.12)	1422	(56.00)
60	60.00	1500	(59.06)	1524	(60.00)

Note: D_o = Outer Diameter

1-9. Manual Organization

Chapter 2 of this manual provides basic principles and guidance for design. Chapter 3 presents engineering calculations and requirements for all piping systems, regardless of construction material. Subsequent chapters address engineering requirements for specific materials of construction, valves, ancillary equipment, and corrosion protection.

a. Fluid/Material Matrix

Appendix B contains a matrix that compares pipeline material suitability for different process applications. Design for specific process applications should consider temperature, pressure and carrier fluid. The use of Appendix B is addressed in Chapter 3.

Chapter 2 Design Strategy

2-1. Design Analyses

The design analyses includes the design of the process piping systems. The design criteria includes applicable codes and standards, environmental requirements, and other parameters which may constrain the work.

a. Calculations

Engineering calculations included in the design analyses document the piping system design. Combined with the piping design criteria, calculations define the process flow rates, system pressure and temperature, pipe wall thickness, and stress and pipe support requirements. Design calculations are clear, concise, and complete. The design computations should document assumptions made, design data, and sources of the data. All references (for example, manuals, handbooks, and catalog cuts), alternate designs investigated, and planned operating procedures are included. Computer-aided design programs can be used but are not a substitute for the designer's understanding of the design process.

b. System Descriptions

System descriptions provide the functions and major features of each major system and may require inputs from mechanical, electrical and process control disciplines. The system description contains system design bases, operating modes and control concepts, and both system and component performance ratings. System descriptions provide enough information to develop process flow diagrams (PFDs), piping and instrumentation diagrams (P&IDs), and to obtain any permits or approvals necessary to proceed. Table 2-1 lists the typical contents of a system description.

2-2. Specifications

Piping specifications define material, fabrication, installation and service performance requirements. The work conforms to ER 1110-345-700, Design Analysis, Drawings and Specifications. In addition, the project design must adhere to general quality policy and principles as described in ER 1110-1-12, Quality Management.

**Table 2-1
System Description**

1. Function
2. Bases of Design
Environmental
Safety
Performance Requirements
Codes and Standards
3. Description
General Overview
System Operation
Major Components

2-3. Drawings

Contract drawings include layout piping drawings, fabrication or detail drawings, equipment schedules, and pipe support drawings. Isometric drawings may also be included and are recommended as a check for interferences and to assist in pipe stress analyses. A detailed pipe support drawing containing fabrication details is required. Piping supports can be designed by the engineer or the engineer may specify the load, type of support, direction and degree of restraint.

a. Drawings Requirements

The requirements and procedures for the preparation and approval of drawings shall meet ER 1110-345-700, Design Analysis, Drawings and Specifications. This regulation addresses the stages of design and construction, other than shop drawings.

b. Process Flow Diagram (PFD) Content

PFDs are the schematic illustrations of system descriptions. PFDs show the relationships between the major system components. PFDs also tabulate process design values for different operating modes, typically normal, maximum and minimum. PFDs do not show piping ratings or designations, minor piping systems, for example, sample lines or valve bypass lines;

instrumentation or other minor equipment, isolation valves, vents, drains or safety devices unless operable in a described mode. Table 2-2 lists the typical items contained on a PFD, and Figure 2-1 depicts a small and simplified PFD.

Table 2-2 PFDs	
1.	Major Equipment Symbols, Names, Identification Number
2.	Process Piping
3.	Control Valves and Other Valves that Affect Operations
4.	System Interconnections
5.	System Ratings and Operational Variables maximum, average, minimum flow maximum, average, minimum pressure maximum, average, minimum temperature
6.	Fluid Composition

c. Piping and Instrumentation Diagram (P&ID) Content

P&IDs schematically illustrate the functional relationship of piping, instrumentation and system equipment components. P&IDs show all of the piping, including the intended physical sequence of branches, reducers, and valves, etc.; equipment; instrumentation and control interlocks. The P&IDs are used to operate the process systems. Table 2-3 lists the typical items contained on a P&ID, and Figure 2-2 depicts a small and simplified P&ID.

d. Piping Sketches

Major piping sketches may be included in a preliminary design submittal. Sketches of the major piping systems may be overlaid on preliminary equipment locations and structural plans to indicate new pipe runs and provide data input for a cost estimate.

Table 2-3 P&IDs	
1.	Mechanical Equipment, Names and Numbers
2.	All Valves and Identification
3.	Instrumentation and Designations
4.	All Process Piping, Sizes and Identification
5.	Miscellaneous Appurtenances including Vents, Drains, Special Fittings, Sampling Lines, Reducers and Increases
6.	Direction of Flow
7.	Class Change
8.	Interconnections
9.	Control Inputs/Outputs and Interlocks

2-4. Bases of Design

The bases of design are the physical and material parameters; loading and service conditions; and environmental factors that are considered in the detailed design of a liquid process piping system to ensure a reasonable life cycle. The bases of design must be developed in order to perform design calculations and prepare drawings.

a. Predesign Surveys

Predesign surveys are recommended for the design of liquid process piping for new treatment processes and are a necessity for renovation or expansion of existing processes. A site visit provides an overview of the project. Design requirements are obtained from the customer, an overall sense of the project is acquired, and an understanding of the aesthetics that may be involved is developed. For an existing facility, a predesign survey can be used to evaluate piping material compatibility, confirm as-built drawings, establish connections, and develop requirements for aesthetics.

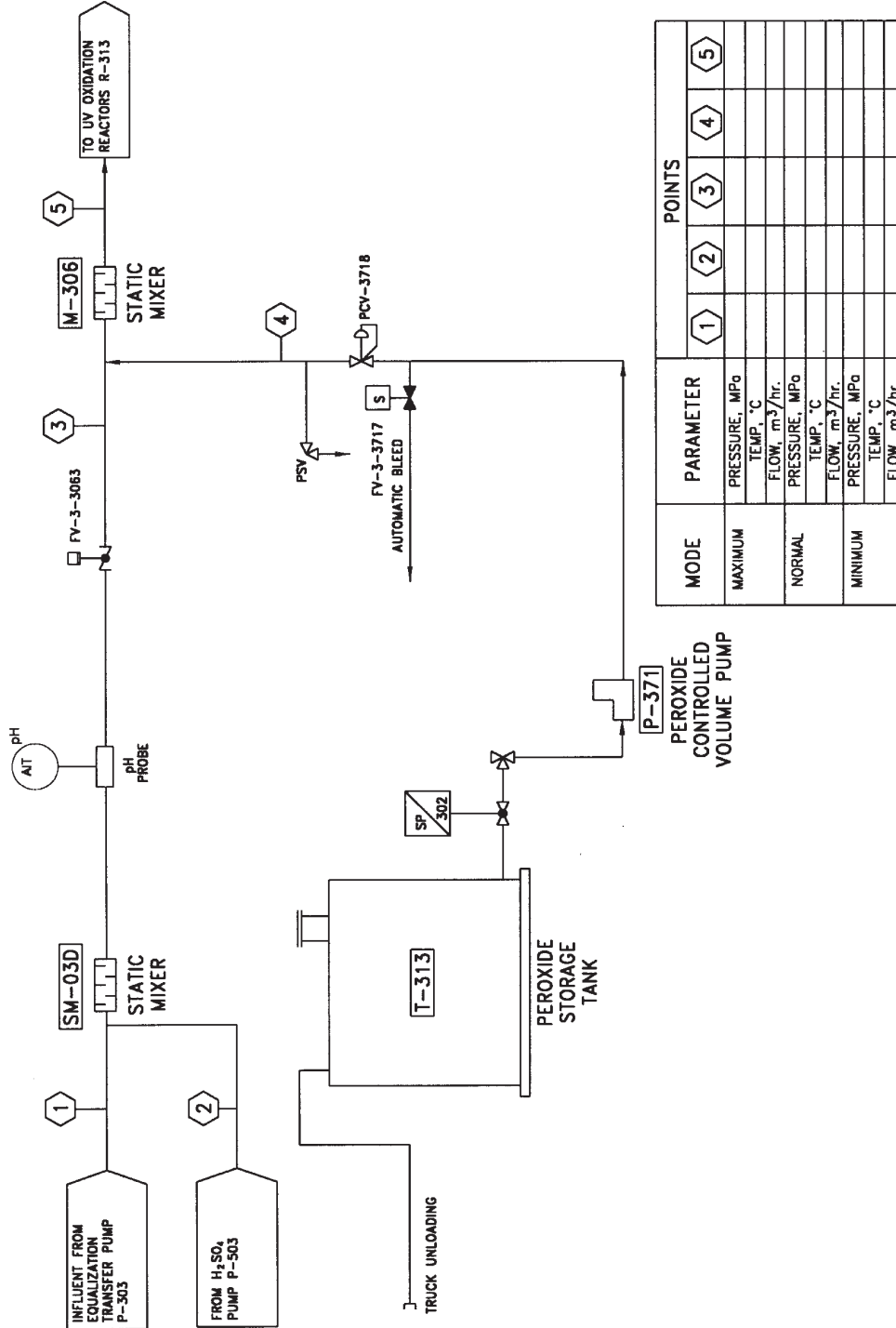

MODE	PARAMETER	1	2	3	4	5
MAXIMUM	PRESSURE, MPo					
	TEMP, °C					
NORMAL	FLOW, m ³ /hr.					
	PRESSURE, MPo					
MINIMUM	TEMP, °C					
	FLOW, m ³ /hr.					
	PRESSURE, MPo					
	TEMP, °C					
	FLOW, m ³ /hr.					

Figure 2-1. Process Flow Diagram (PFD)
(Source: SAIC, 1998.)

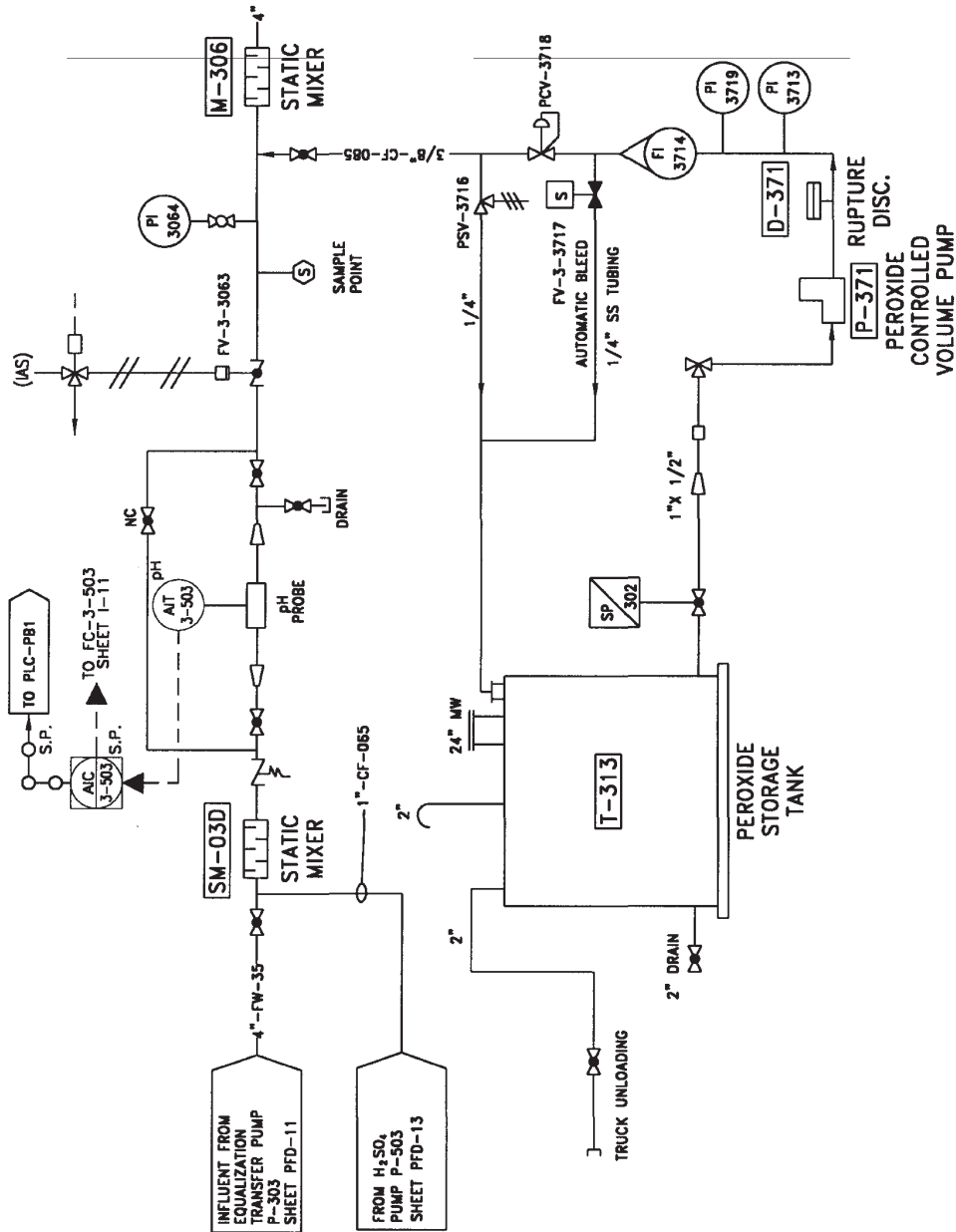

Figure 2-2. Piping and Instrumentation Diagram (P&ID)
(Source: SAIC, 1998.)

Soil conditions play a major role in the selection of piping systems. Soils which contain organic or carbonaceous matter such as coke, coal or cinders, or soils contaminated with acid wastes, are highly corrosive. These conditions impact ferrous metals more than nonferrous metals. For normally acceptable metals, soil variations may be significant. Buried pipes corrode faster at the junction line of dissimilar soils. In fact, electric potentials up to one (1) volt may be generated by placing a metal pipe where it crosses dissimilar soils.

Paragraph 12-2d addresses requirements for predesign surveys and soils sampling that may be necessary to design cathodic protection systems.

b. Service Conditions

The piping system is designed to accommodate all combinations of loading situations (pressure changes, temperature changes, thermal expansion/contraction and other forces or moments) that may occur simultaneously.

These combinations are referred to as the service conditions of the piping. Service conditions are used to set design stress limits and may be defined or specified by code, or are determined based on the system description, site survey, and other design bases.

c. Design Codes and Standards

Standards, codes and specifications referenced throughout this document are issued by the organizations listed in Table 2-4. Codes and standards are reviewed based on project descriptions to determine and verify applicability. This manual generally follows the American Society of Mechanical Engineers (ASME) Code for Pressure Piping, B31. ASME B31 includes the minimum design requirements for various pressure piping applications. While this manual is not comprehensive in including code requirements, it includes standards and recommendations for design of pressure piping.

**Table 2-4
Standards and Codes**

ANSI	American National Standards Institute 11 West 42nd Street, New York, NY 10036
API	American Petroleum Institute 1220 L Street NW, Washington, DC 20005
ASME	The American Society of Mechanical Engineers 345 47th Street, New York, NY 10017
ASQC	American Society for Quality Control P. O. Box 3005, Milwaukee, WI 53201
ASTM	American Society for Testing and Materials 100 Barr Harbor Drive, West Conshohocken, PA 19428
ISO	International Organization for Standardization 1 Rue de Varembe, Geneva, Switzerland
MSS	Manufacturer's Standardization Society for the Valves and Fittings Industry 127 Park Street NE, Vienna, VA 22180
NIST	National Institute of Standards and Technology Department of Commerce Washington, D.C.

Piping codes supply required design criteria. These criteria are rules and regulations to follow when designing a piping system. The following list is a sample of some of the parameters which are addressed by design criteria found in piping codes:

- allowable stresses and stress limits; - allowable dead loads and load limits; - allowable live loads and load limits;
- materials;
- minimum wall thickness;
- maximum deflection;
- seismic loads; and
- thermal expansion.

Codes do not include components such as fittings, valves, and meters. Design of these piping system components should follow industry standards. Standards supply required design criteria and rules for individual components or classes of components, such as valves, meters, and fittings. The purpose of standards is to specify rules for each manufacturer of these components. This permits component interchangeability in a piping system. Standards apply to both dimensions and performance of system components and are prescribed when specifying construction of a piping system.

d. Environmental Factors

The potential for damage due to corrosion must be addressed in the design of process piping. Physical damage may also occur due to credible operational and natural phenomena, such as fires, earthquakes, high winds, snow or ice loading, and subsidence. Two instances of temperature changes must be considered as a minimum. First, there are diurnal and seasonal changes. Second, thermal expansion where elevated liquid temperatures are used must be accommodated. Compensation for the resulting expansions and contractions are made in both the piping system and support systems. Internal wear and erosion also pose unseen hazards that can result in system failures.

Chapter 4 discusses why corrosion occurs in metallic piping, the problems that can result from corrosion, and how appropriate material choices can be made to minimize corrosion impacts. All underground ferrous piping must be cathodically protected. Chapter 12 of this

manual, TM 5-811-7 (Army) and MIL-HDBK-1004/10 (Air Force), contain additional guidance pertaining to cathodic protection of underground pipelines.

Design concerns for the effects of physically damaging events fall into two broad categories: operational phenomena (for example, fires, spills, power outages, impacts/collisions, and breakdown or failure of associated equipment) and natural phenomena (for example, seismic occurrences, lightning strikes, wind, and floods). Risk is a combination of probability and consequence. There are infinite possibilities and all scenarios will not be covered by direct reference to codes. Design experience must be combined with a thorough evaluation of the likelihood of all abnormal events.

Working fluids carry abrasives that may wear internal surfaces. The accumulating damage may be impossible to observe until after system failure has occurred. The most effective defense against this damage is to design protection into the system. Depending upon the process, monitoring pipe wall thicknesses may be necessary as an additive or alternate method to prevent failure due to erosion.

It may not be practical in many cases to provide corrosion-resistant materials due to structural needs or other overriding physical constraints. In these cases, the most effective solution may be to design thicker components to allow for the effects of corrosion occurring, over time. However, an understanding of a system's environmental factors is required. For example, although it is generally true that thicker components will last longer in a corrosive situation, in a situation where severe pitting corrosion (see Paragraph 4-2 for definitions and description of various types of corrosion) is occurring thicker components may not last much longer than those with standard thicknesses. In this case other design solutions are provided.

The most common installation constraint is the need to avoid interconnection of dissimilar metals. For example, piping is often totally destroyed by connecting brass valves to carbon steel pipe. Short, easily replaced spools may be considered for installation on both sides of such components in order to protect the piping.

e. Safety Provisions

Safety provisions as required by EM 385-1-1, The Safety and Health Requirements Manual, USACE guide specifications, trade standards, codes, and other manuals are referenced here. Requirements of the Occupational Safety and Health Administration (OSHA) are minimum design constraints in USACE projects.

(1) For transient pressure conditions which exceed the design pressure by 10 percent or less and act for less than 10 percent of the total operating time, neglect the transient and do not increase the design pressure.

(2) For transients whose magnitude or duration is greater than 10 percent of the design pressure or operating time, increase the design pressure to encompass the range of the transient.

2-5. Loading Conditions

As described in Paragraph 2-4, the stresses on a piping system define the service conditions of the piping system and are a function of the loads on that system. The sources of these loads are internal pressure, piping system dead weight, differential expansion due to temperature changes, wind loads, and snow or ice loads. Loads on a piping system are classified as sustained or occasional loads.

The determination of design pressure and analysis of pressure transients are addressed in Paragraph 3-2.

Dead weight is the dead load of a piping system or the weight of the pipe and system components. Dead weight generally does not include the weight of the system fluid. The weight of the fluid is normally considered an occasional load by code.

a. Sustained Loads

Sustained loads are those loads that do not vary considerably over time and are constantly acting on the system. Examples of sustained loads are the pressures, both internal and external, acting on the system and the weight of the system. The weight of the system includes both that of the piping material and the operating fluid.

For buried piping, dead weight is not a factor. However, a sustained load that is analyzed is the load from the earth above the buried piping. Because of the different potential for deformation, the effects of an earth load on flexible piping and rigid piping are analyzed differently. Paragraph 5-1 f addresses earth loads on buried flexible piping. The earth load on rigid piping may be calculated using the following formula.¹

$$F_E = \frac{\omega H}{a}$$

where:

- F_E = earth load, kPa (psi)
- ω = soil weight, kg/m³ (lb/ft³); typically 1,922 kg/m³ (120 lb/ft³)
- H = height of cover, m (ft)
- a = conversion factor, 102 kg/m²/kPa (144 lb/ft²/psi).

The sustained maximum system operating pressure is the basis for the design pressure. The design temperature is the liquid temperature at the design pressure. The minimum wall thickness of the pipe and the piping components pressure rating is determined by the design temperature and pressure. Although the design pressure is not to be exceeded during normal, steady-state operations, short-term system pressure excursions in excess of the design pressures occur. These excursions are acceptable if the pressure increase and the time durations are within code defined limits.

b. Occasional Loads

Piping codes provide design guidance and limits for design pressure excursions. If a code does not have an over-pressure allowance, transient conditions are accounted for within the system design pressure. A reasonable approach to over-pressure conditions for applications without a specific design code is:

Occasional loads are those loads that act on the system on an intermittent basis. Examples of occasional loads are those placed on the system from the hydrostatic leak test, seismic loads, and other dynamic loads. Dynamic loads are those from forces acting on the system, such as forces

¹ AWWA C150, pp. 4-5.

caused by water hammer (defined on page 3-5) and the energy released by a pressure relief device. Another type of occasional load is caused by the expansion of the piping system material. An example of an expansion load is the thermal expansion of pipe against a restraint due to a change in temperature.

Wind load is a transient, live load (or dynamic load) applied to piping systems exposed to the effects of the wind. Obviously the effects of wind loading can be neglected for indoor installation. Wind load can cause other loads, such as vibratory loads, due to reaction from a deflection caused by the wind. The design wind speed is determined from ASCE 7 and/or TI 809-01, Load Assumptions for Buildings, although a minimum of 161 km/h (100 miles per hour) will be used. By manipulating Bernoulli's equation, the following equation may be obtained to calculate the horizontal wind load on a projected pipe length.

$$F_w = C_{w1} V_w^2 C_D D_o$$

where:

- F_w = design wind load per projected pipe length, N/m (lb/ft)
- V_w = design wind speed, m/s (miles/hr)
- C_D = drag coefficient, dimension less
- D_o = pipe (and insulation) outside diameter, mm (in)
- C_{w1} = constant, 2.543×10^{-6} (N/m)/[mm(m/s)] (2.13×10^{-4} (lb/ft)/[in(mile/hr)]).

The drag coefficient is obtained from ASCE 7 and is a function of the Reynolds Number, R_e , of the wind flow across the projected pipe.

$$R_e = C_{w2} V_w D_o$$

where:

- R_e = Reynolds Number
- V_w = design wind speed, m/s (miles/hr)
- D_o = pipe (and insulation) outside diameter, mm (in)
- C_{w2} = constant, 6.87 s/mm-m (780 hr/in-mile).

Snow and ice loads are live loads acting on a piping system. For most heavy snow climates, a minimum snow load of 1.2 kPa (25 psf) is used in the design. In some

cases, local climate and topography dictate a larger load. This is determined from ANSI A58.1, local codes or by research and analysis of other data. Snow loads can be ignored for locations where the maximum snow is insignificant. Ice buildup may result from the environment, or from operating conditions.

The snow loads determined using ANSI A58.1 methods assume horizontal or sloping flat surfaces rather than rounded pipe. Assuming that snow laying on a pipe will take the approximate shape of an equilateral triangle with the base equal to the pipe diameter, the snow load is calculated with the following formula.

$$W_s = \frac{1}{2} n D_o S_L$$

where:

- W_s = design snow load acting on the piping, N/m (lb/ft)
- D_o = pipe (and insulation) outside diameter, mm (in)
- S_L = snow load, Pa (lb/ft²)
- n = conversion factor, 10^{-3} m/mm (0.083 ft/in).

Ice loading information does not exist in data bases like snow loading. Unless local or regional data suggests otherwise, a reasonable assumption of 50 to 75 mm (2 to 3 in) maximum ice accumulation is used to calculate an ice loading:

$$W_I = \pi n_3 S_I t_I (D_o + t_I)$$

where:

- W_I = design ice load, N/m (lbs/ft)
- S_I = specific weight of ice, 8820 N/m³ (56.1 lbs/ft³)
- t_I = thickness of ice, mm (in)
- D_o = pipe (and insulation) outside diameter, mm (in)
- n_3 = conversion factor, 10^{-6} m²/mm² (6.9×10^{-4} ft²/in²).

Seismic loads induced by earthquake activity are live (dynamic) loads. These loads are transient in nature. Appropriate codes are consulted for specifying piping systems that may be influenced by seismic loads. Seismic zones for most geographical locations can be found in TM 5-809-10, American Water Works Association

(AWWA) D110, AWWA D103, or CEGS 13080, Seismic Protection for Mechanical Electrical Equipment. ASME B31.3 (Chemical Plant and Petroleum Refinery Piping) requires that the piping is designed for earthquake induced horizontal forces using the methods of ASCE 7 or the Uniform Building Code.

Hydraulic loads are by their nature transient loads caused by an active influence on a piping system. Examples of dynamic loads inherent to piping systems are pressure surges such as those caused by pump starts and stops, valve actuation, water hammer, and by the energy discharged by a pressure relief valve. Examples of hydraulic loads causing pressure transients and the effect upon the design are provided in Paragraph 3-2b.

Vibration in a piping system is caused by the impact of fluctuating force or pressure acting on the system. Mechanical equipment such as pumps can cause vibrations. Typically the low to moderate level of periodic excitation caused by pumps do not result in damaging vibration. The potential for damage occurs when the pressure pulses or periodic forces equate with the natural resonant frequencies of the piping system. TM 5-805-4, Noise and Vibration Control, provides design recommendations for vibration control, particularly vibration isolation for motor-pump assemblies. In addition, TM 5-805-4 recommends the following vibration isolation for piping systems:

For connections to rotating or vibrating equipment, use resilient pipe supports and:

- the first three supports nearest the vibrating equipment should have a static deflection equal to $\frac{1}{2}$ of that required for the equipment; the remaining pipe supports should have a static deflection of 5 to 12.5 mm (0.2 to 0.49 in);
- provide a minimum 25 mm (1 in) clearance for a wall penetration, support the pipe on both sides of the penetration to prevent the pipe from resting on the wall, and seal the penetration with a suitable compound (fire-stop system, if required);
- use neoprene isolators in series with steel spring isolators;

- always include a neoprene washer or grommet with ceiling hangers; and
- inspect hanger rods during installation to ensure that they are not touching the side of the isolator housings.

Flexible pipe connections should have a length of 6 to 10 times the pipe diameter and be a bellows-type or wire-reinforced elastomeric piping. Tie-rods are not used to bolt the two end flanges together².

Loads applied to a piping system can be caused by forces resulting from thermal expansion and contraction. A load is applied to a piping system at restraints or anchors that prevent movement of the piping system. Within the pipe material, rapid changes in temperature can also cause loads on the piping system resulting in stresses in the pipe walls. Finally, loads can be introduced in the system by combining materials with different coefficients of expansion.

Movements exterior to a piping system can cause loads to be transmitted to the system. These loads can be transferred through anchors and supports. An example is the settlement of the supporting structure. The settling movement transfers transient, live loads to the piping system.

Live loads can result from the effects of vehicular traffic and are referred to as wheel loads. Because above ground piping is isolated from vehicle traffic, these live loads are only addressed during the design of buried piping. In general, wheel loads are insignificant when compared to sustained loads on pressure piping except when buried at “shallow” depths.³ The term shallow is defined based upon both site specific conditions and the piping material. “However, as a rule, live loads diminish rapidly for laying depths greater than about four feet for highways and ten feet for railroads.”⁴ Wheel loads are calculated using information in AASHTO H20 and guidance for specific materials such as AWWA C150 (ductile-iron and metallic), AWWA C900 (PVC) and AWWA C950 (FRP). For example, wheel loads for rigid metallic piping over an effective length of 0.91 m (3 ft) can be calculated using the following formula.⁵

² TM 5-805-4, pp. 8-10 - 8-11.

³ EM 1110-2-503, p. 7-15.

⁴ Ibid., p. 7-15.

⁵ AWWA C150, pp. 4-5.

$$F_w = \frac{C R P F}{b D_o}$$

where:

- F_w = wheel load, kPa (psi)
- C = surface load factor, see AWWA C150, Table 10.6M/10.6
- R = reduction factor for a AASHTO H20 truck on an unpaved or flexible paved road, see AWWA C150, Table 10.4M/10.4
- P = wheel weight, kg (lb); typically 7,257 kg (16,000 lb)
- F = impact factor; typically 1.5
- b = conversion factor, 0.031 kg/m/kPa (12 lb/ft/psi)
- D_o = pipe outside diameter, mm (in).

2-6. Piping Layout

The bases of design establish the factors that must be included in liquid process piping design. The preparation of the piping layout requires a practical understanding of complete piping systems, including material selections, joining methods, equipment connections, and service applications. The standards and codes previously introduced establish criteria for design and construction but do not address the physical routing of piping.

a. Computer Aided Drafting and Design

Computer based design tools, such as computer aided draft and design (CADD) software, can provide powerful and effective means to develop piping layouts. Much of the commercially available software can improve productivity and may also assist in quality assurance, particularly with interference analyses. Some CADD software has the ability to generate either 3-dimensional drawings or 2-dimensional drawings, bills of material, and databases.

b. Piping Layout Design

System P&IDs; specifications; and equipment locations or layout drawings that are sufficiently developed to show equipment locations and dimensions, nozzle locations and pressure ratings are needed to develop the piping layout. A completely dimensioned pipe routing from one point of connection to another with all appurtenances and branches as shown on the P&ID is prepared.

Pipe flexibility is required to help control stress in liquid piping systems. Stress analysis may be performed using specialized software. The bases of the analyses are developed in Chapter 3. Considerations that must be accounted for in routing piping systems in order to minimize stress include: avoiding the use of a straight pipe run between two equipment connections or fixed anchor points (see Figure 2-3); locating fixed anchors near the center of pipe runs so thermal expansion can occur in two directions; and providing enough flexibility in branch connections for header shifts and expansions.

The load and minimum spacing requirements and support hardware are addressed throughout this manual. The layout design must also deal with piping support. Piping on racks are normally designed to bottom of pipe (BOP) elevations rather than centerline.

In addition, the piping layout should utilize the surrounding structure for support where possible. Horizontal and parallel pipe runs at different elevations are spaced for branch connections and also for independent pipe supports.

Interferences with other piping systems; structural work; electrical conduit and cable tray runs; heating, ventilation and air conditioning equipment; and other process equipment not associated with the liquid process of concern must be avoided. Insulation thickness must be accounted for in pipe clearances. To avoid interferences, composite drawings of the facility are typically used. This is greatly aided by the use of CADD software. Figure 2-4 presents a simple piping layout and Figure 2-5 is a CADD generated 3-dimensional drawing of the layout. However, as mentioned previously in this chapter communications between engineering disciplines must be maintained as facilities and systems are typically designed concurrently though designs may be in different stages of completion.

Lay lengths and other restrictions of in-line piping equipment and other system equipment constraints must be considered. For example, valve location considerations are listed in Table 2-5. Valves and other equipment such as flow instrumentation and safety relief devices have specific location requirements such as minimum diameters of straight run up- and downstream, vertical positioning and acceptable velocity ranges that require pipe diameter changes. Manufacturers should be consulted for specific requirements.

Piping connections to pumps affect both pump operating efficiency and pump life expectancy. To reduce the effects, the design follows the pump manufacturer's installation requirements and the Hydraulic Institute Standards, 14th Edition. Table 2-6 provides additional guidelines. The project process engineer should be consulted when unique piping arrangements are required.

Miscellaneous routing considerations are: providing piping insulation for personnel protection, access for future component maintenance, heat tracing access, hydrostatic test fill and drain ports, and air vents for testing and startup operations. System operability, maintenance, safety, and accessibility are all considerations that are addressed in the design.

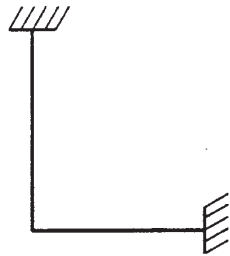

a. L-Shaped

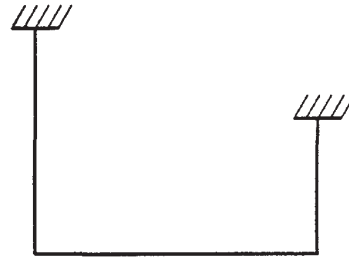

b. U-Shaped

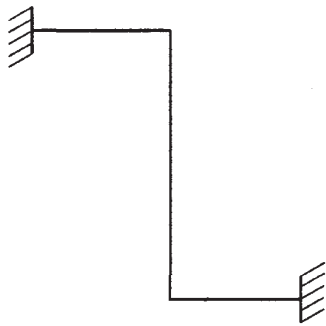

c. Z-Shaped

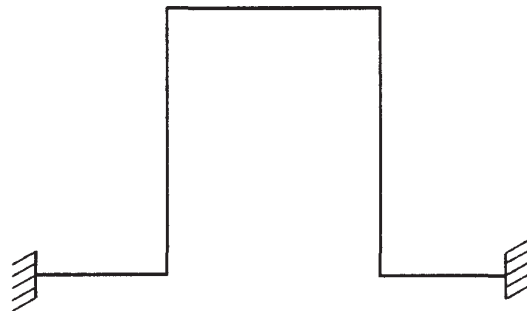

d. Expansion Loop (Without Guides)

Figure 2-3. Flexibility Arrangements
(Source: SAIC, 1998.)

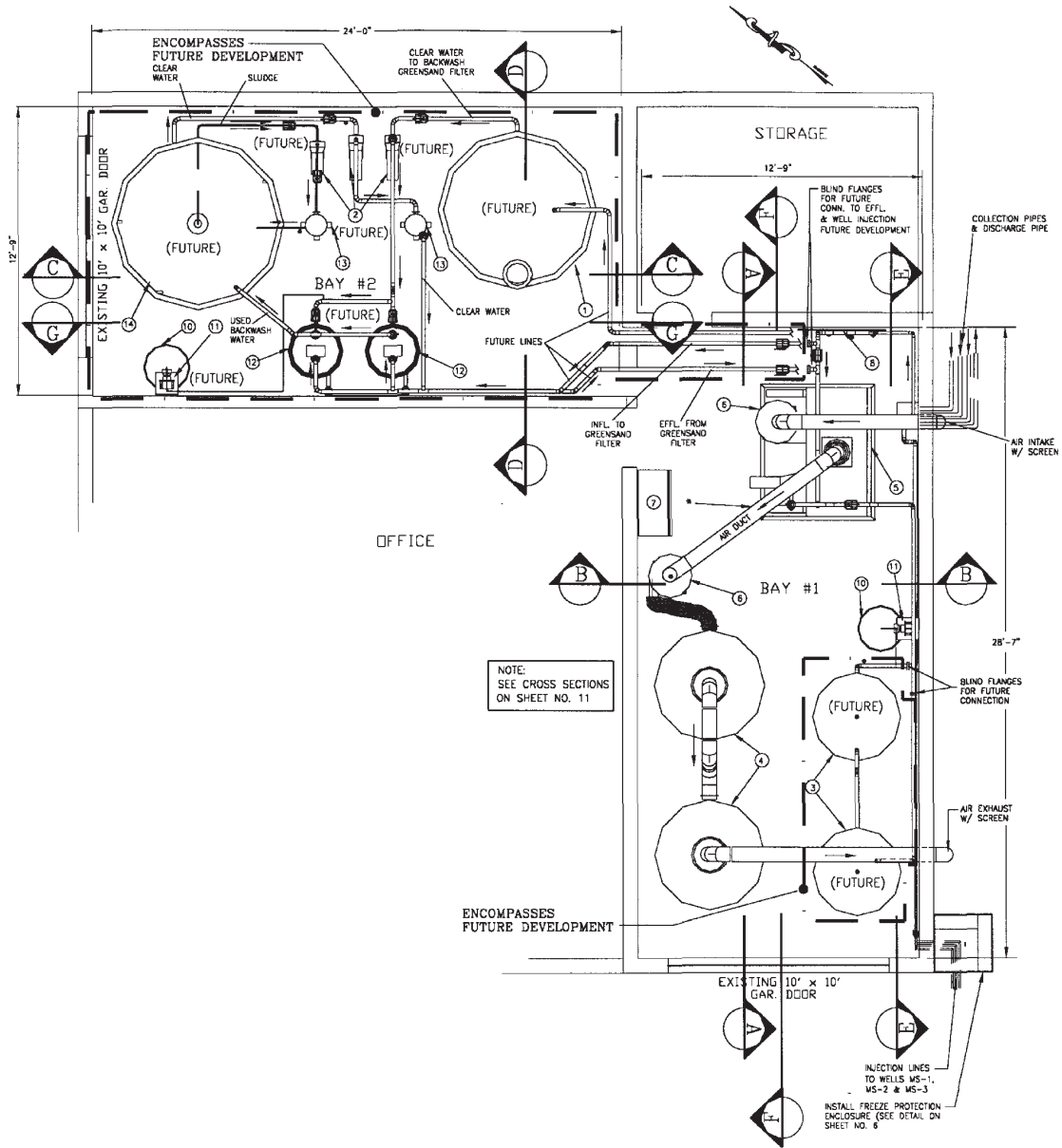

Figure 2-4. Remediation Process Piping Plan
(Source: SAIC, 1998.)

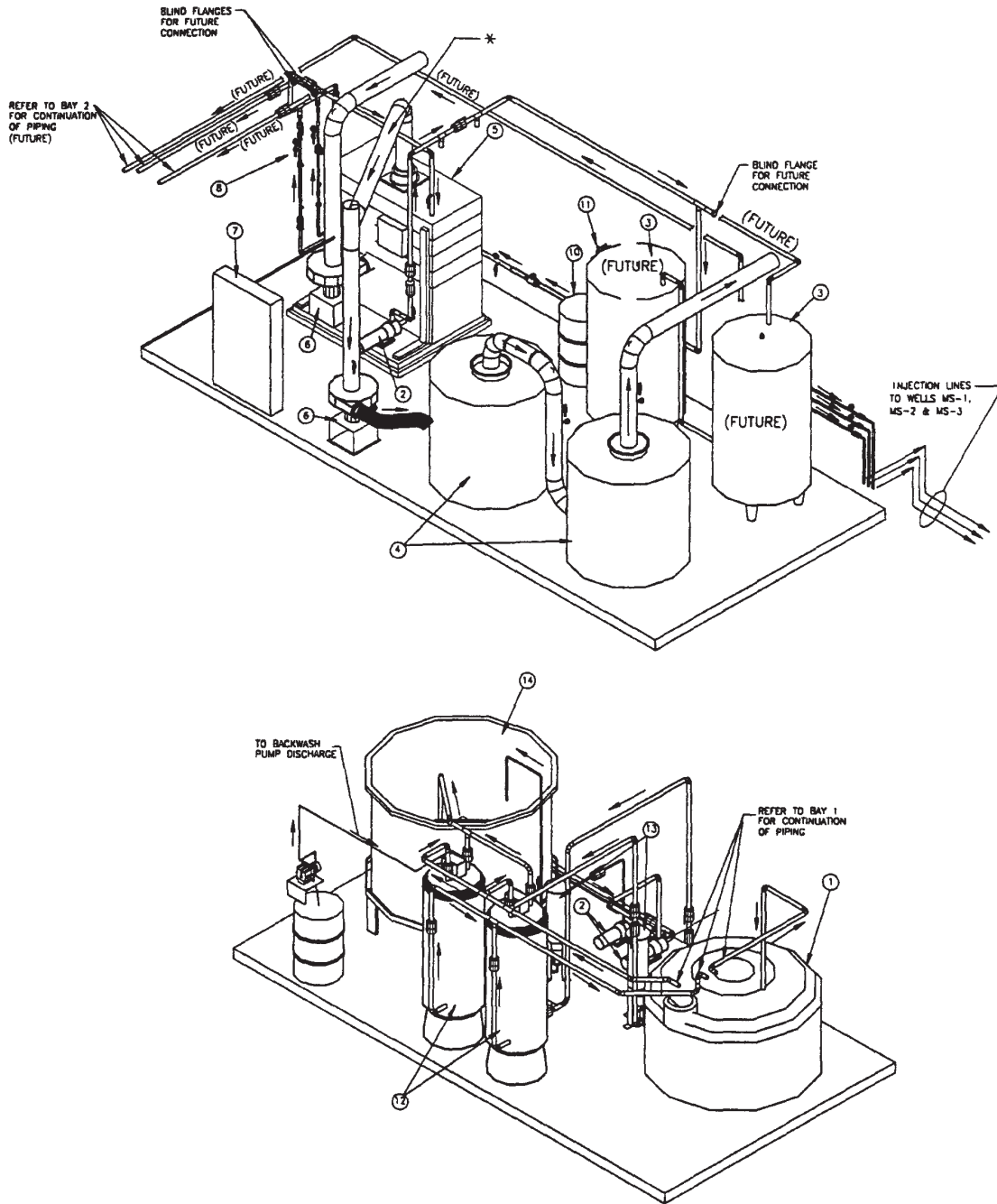

Figure 2-5. Isometric View
(Source: SAIC, 1998.)

**Table 2-5
Valve Location Design**

1. Control valves - install with a minimum of 3 diameters of straight run both upstream and downstream, and install vertically upright.
2. Butterfly and check valves - install with a minimum of 5 diameters of straight run upstream.
3. Non-control valves - install with stems in the horizontal to vertical positions and avoid head, knee, and tripping hazards.
4. Chemical service valves - locate below eye level.
5. All valves - provide a minimum of 100 mm (3.94 in.) hand clearance around all hand wheels, allow space for valve parts removal or maintenance, and avoid creating water hammer conditions.

Note: These guidelines are generally accepted practices. However, designs should conform to manufacturer's recommendations and commercial standards; for example, ASME and ISA standards.

Source: SAIC, 1998.

**Table 2-6
Pump Connections Design**

Supports	Piping is independently supported from the pump. A pipe anchor is provided between a flexible coupling and the pump.
Suction Connections	The pump suction is continuously flooded, has 3 diameters of straight run, uses long radius elbows, and can accommodate a temporary in-line strainer.
Fittings	An eccentric reducer, flat side up, is provided when a pipe reduction is required at the pipe suction. Flanges mating to flat faced pump flanges are also flat faced and use full-faced gaskets and common (normal strength) steel bolting.

Note: These guidelines are generally accepted practices. However, designs should conform to manufacturer's recommendations and Hydraulic Institute Standards.

Source: SAIC, 1998.

Chapter 3 General Piping Design

3-1. Materials of Construction

Most failures of liquid process systems occur at or within interconnect points - - the piping, flanges, valves, fittings, etc. It is, therefore, vital to select interconnecting equipment and materials that are compatible with each other and the expected environment. Materials selection is an optimization process, and the material selected for an application must be chosen for the sum of its properties. That is, the selected material may not rank first in each evaluation category; it should, however, be the best overall choice. Considerations include cost and availability. Key evaluation factors are strength, ductility, toughness, and corrosion resistance.

a. Strength

The strength of a material is defined using the following properties: modulus of elasticity, yield strength, and ultimate tensile strength. All of these properties are determined using ASTM standard test methods.

The modulus of elasticity is the ratio of normal stress to the corresponding strain for either tensile or compressive stresses. Where the ratio is linear through a range of stress, the material is elastic; that is, the material will return to its original, unstressed shape once the applied load is removed. If the material is loaded beyond the elastic range, it will begin to deform in a plastic manner. The stress at that deformation point is the yield strength. As the load is increased beyond the yield strength, its cross-sectional area will decrease until the point at which the material cannot handle any further load increase. The ultimate tensile strength is that load divided by the original cross-sectional area.

b. Ductility

Ductility is commonly measured by either the elongation in a given length or by the reduction in cross-sectional area when subjected to an applied load. The hardness of a material is a measure of its ability to resist deformation. Hardness is often measured by either of two standard scales, Brinell and Rockwell hardness.

c. Toughness

The toughness of a material is dependent upon both strength and ductility. Toughness is the capability of a material to resist brittle fracture (the sudden fracture of materials when a load is rapidly applied, typically with little ductility in the area of the fracture). Two common ASTM test methods used to measure toughness are the Charpy Impact and Drop-Weight tests. The Charpy brittle transition temperature and the Drop-Weight NDTT are important design parameters for materials that have poor toughness and may have lower operating temperatures. A material is subject to brittle, catastrophic failure if used below the transition temperature.

d. Corrosion Resistance

Appendix B provides a matrix that correlates process fluids, piping materials and maximum allowable process temperatures to assist in determining material suitability for applications.

e. Selection Process

Piping material is selected by optimizing the basis of design. First, eliminate from consideration those piping materials that:

- are not allowed by code or standard;
- are not chemically compatible with the fluid;
- have system rated pressure or temperatures that do not meet the full range of process operating conditions; and
- are not compatible with environmental conditions such as external corrosion potential, heat tracing requirements, ultraviolet degradation, impact potential and specific joint requirements.

The remaining materials are evaluated for advantages and disadvantages such as capital, fabrication and installation costs; support system complexity; compatibility to handle thermal cycling; and cathodic protection requirements. The highest ranked material of construction is then selected. The design proceeds with pipe sizing, pressure-integrity calculations and stress analyses. If the selected piping material does not meet those requirements, then

the second ranked material is used and the pipe sizing, pressure-integrity calculations and stress analyses are repeated.

Example Problem 1:

Assume a recovered material process line that handles nearly 100% ethyl benzene at 1.20 MPa (174 psig) and 25°C (77°F) is required to be installed above ground. The piping material is selected as follows:

Solution: Step 1. Above ground handling of a flammable liquid by thermoplastic piping is not allowed by ASME B31.3¹.

Step 2. Review of the Fluid/Material Corrosion Matrix (Appendix B) for ethyl benzene at 25°C (77°F) indicates that aluminum, Hastelloy C, Monel, TP316 stainless steel, reinforced furan resin thermoset and FEP lined pipe are acceptable for use. FKM is not available in piping.

Step 3. Reinforced furan resin piping is available to a system pressure rating of 689 kPa (100 psig)²; therefore, this material is eliminated from consideration. The remainder of the materials have available system pressure ratings and material allowable stresses greater than the design pressure.

Step 4. FEP lined piping is not readily available commercially. Since other material options exist, FEP lined piping is eliminated from consideration.

Step 5. The site specific environmental conditions are now evaluated to determine whether any of the remaining materials (aluminum, Hastelloy C, Monel or TP316 stainless steel) should be eliminated prior to ranking. The material is then selected based on site specific considerations and cost.

3-2. Design Pressure

After the piping system's functions, service conditions, materials of construction and design codes and standards have been established (as described in Chapter 2) the next step is to finalize the system operational pressures and temperatures. Up to this point, the system operating

pressure has been addressed from a process requirement viewpoint to ensure proper operation of the system as a whole. At this point in the detail design of the piping system, it is necessary to ensure that the structural integrity of the pipe and piping system components is maintained during both normal and upset pressure and temperature conditions. In order to select the design pressure and temperature, it is necessary to have a full understanding and description of all operating processes and control system functions. The pressure rating of a piping system is determined by identifying the maximum steady state pressure, and determining and allowing for pressure transients.

a. Maximum Steady State Pressure

The determination of maximum steady state design pressure and temperature is based on an evaluation of specific operating conditions. The evaluation of conditions must consider all modes of operation. This is typically accomplished utilizing design references, codes and standards. An approach using the code requirements of ASME B31.3 for maximum pressure and temperature loads is used herein for demonstration.

Piping components shall be designed for an internal pressure representing the most severe condition of coincident pressure and temperature expected in normal operation.³ This condition is by definition the one which results in the greatest required pipe thickness and the highest flange rating. In addition to hydraulic conditions based on operating pressures, potential back pressures, surges in pressures or temperature fluctuations, control system performance variations and process upsets must be considered. The system must also be evaluated and designed for the maximum external differential pressure conditions.

Piping components shall be designed for the temperature representing the most severe conditions described as follows:

- for fluid temperatures below 65°C (150°F), the metal design temperature of the pipe and components shall be taken as the fluid temperature.

¹ ASME B31.3, p. 95.

² Schweitzer, Corrosion-Resistant Piping Systems, p. 140.

³ ASME B31.3, p. 11.

- for fluid temperatures above 65°C (150°F), the metal design temperature of uninsulated pipe and components shall be taken as 95% of the fluid temperature, except flanges, lap joint flanges and bolting shall be 90%, 85% and 80% of the fluid temperature, respectively.
- for insulated pipe, the metal design temperature of the pipe shall be taken as the fluid temperature unless calculations, testing or experience based on actual field measurements can support the use of other temperatures.
- for insulated and heat traced pipe, the effect of the heat tracing shall be included in the determination of the metal design temperature.⁴

In addition to the impact of elevated temperatures on the internal pressure, the impact of cooling of gases or vapors resulting in vacuum conditions in the piping system must be evaluated.

b. Pressure Transients

As discussed in Paragraph 2-5, short-term system pressure excursions are addressed either through code defined limits or other reasonable approaches based on experience. The ASME B31.3 qualification of acceptable pressure excursions states:

“302.2.4 Allowances for Pressure and Temperature Variations. Occasional variations of pressure or temperature, or both, above operating levels are characteristic of certain services. The most severe conditions of coincident pressure and temperature during the variation shall be used to determine the design conditions unless all of the following criteria are met.

- (a) The piping system shall have no pressure containing components of cast iron or other nonductile metal.*
- (b) Nominal pressure stresses shall not exceed the yield strength at temperature (see para. 302.3 of this Code [ASME B31.3] and S_y data in [ASME] BPV Code, Section II, Part D, Table Y-1).*
- (c) Combined longitudinal stress shall not exceed the limits established in paragraph 302.3.6 [of ASME B31.3].*

(d) The total number of pressure-temperature variations above the design conditions shall not exceed 1000 during the life of the piping system.

(e) In no case shall the increased pressure exceed the test pressure used under para. 345 [of ASME B31.3] for the piping system.

(f) Occasional variations above design conditions shall remain within one of the following limits for pressure design.

(1) Subject to the owner's approval, it is permissible to exceed the pressure rating or the allowable stress for pressure design at the temperature of the increased condition by not more than:

(a) 33% for no more than 10 hour at any one time and no more than 100 hour per year; or

(b) 20% for no more than 50 hour at any one time and no more than 500 hour per year.

The effects of such variations shall be determined by the designer to be safe over the service life of the piping system by methods acceptable to the owner. (See Appendix V [of ASME B31.3])

(2) When the variation is self-limiting (e.g., due to a pressure relieving event), and lasts no more than 50 hour at any one time and not more than 500 hour/year, it is permissible to exceed the pressure rating or the allowable stress for pressure design at the temperature of the increased condition by not more than 20%.

(g) The combined effects of the sustained and cyclic variations on the serviceability of all components in the system shall have been evaluated.

(h) Temperature variations below the minimum temperature shown in Appendix A [of ASME B31.3] are not permitted unless the requirements of para. 323.2.2 [of ASME B31.3] are met for the lowest temperature during the variation.

⁴ ASME B31.3, pp. 11-12.

(i) *The application of pressures exceeding pressure-temperature ratings of valves may under certain conditions cause loss of seat tightness or difficulty of operation. The differential pressure on the valve closure element should not exceed the maximum differential pressure rating established by the valve manufacturer. Such applications are the owner's responsibility.*⁵

The following example illustrates a typical procedure for the determination of design pressures.

Example Problem 2:

Two motor-driven boiler feed pumps installed on the ground floor of a power house supply 0.05 m³/s (793 gpm) of water at 177°C (350°F) to a boiler drum which is 60 m (197 ft) above grade. Each pump discharge pipe is 100 mm (4 in), and the common discharge header to the boiler drum is a 150 mm (6 in) pipe. Each pump discharge pipe has a manual valve that can isolate it from the main header. A relief valve is installed upstream of each pump discharge valve to serve as a minimum flow bypass if the discharge valve is closed while the pump is operating. The back pressure at the boiler drum is 17.4 MPa (2,520 psig). The set pressure of the relief valve is 19.2 MPa (2,780 psig), and the shutoff head of each pump is 2,350 m (7,710 ft). The piping material is ASTM A 106, Grade C, with an allowable working stress of 121 MPa (17,500 psi), over the temperature range of -6.7 to 343°C (-20 to 650°F). The corrosion allowance is 2 mm (0.08 in) and the design code is ASME B31.1 (Power Piping).

The design pressures for the common discharge header and the pump discharge pipes upstream of the isolation valve must be determined. Also the maximum allowable pressure is to be calculated assuming the relief valve on a pump does not operate when its discharge valve is closed.

Solution:

Step 1. Determination of design pressure for the 150 mm (6 in) header is as follows. The specific volume of 177°C (350°F) saturated water is 0.001123 m³/kg (0.01799 ft³/lbm). The specific volume is corrected for

the effects of compression to 17.2 MPa (2,500 psig) using steam tables:

$$v - v_f = -0.000013 \text{ m}^3/\text{kg} \text{ } (-0.00021 \text{ ft}^3/\text{lbm})$$

$$v_f \text{ at } 177^\circ\text{C (350}^\circ\text{F)} = 0.001123 \text{ m}^3/\text{kg} \\ (0.01799 \text{ ft}^3/\text{lbm}), \text{ saturated}$$

$$v \text{ at } 17.2 \text{ MPa (2,500 psig)}$$

$$= 0.001123 \text{ m}^3/\text{kg} + (-0.000013 \text{ m}^3/\text{kg})$$

$$= 0.001110 \text{ m}^3/\text{kg} \text{ } (0.01778 \text{ ft}^3/\text{lbm}), \\ \text{compressed}$$

where:

v = specific volume of water, m³/kg (ft³/lbm)

v_f = specific volume of feed water, m³/kg (ft³/lbm)

The static head above the pumps due to the elevation of the boiler drum is:

$$P_{st} = (60 \text{ m}) \left(\frac{1}{0.001110 \frac{\text{m}^3}{\text{kg}}} \right) \left(9.81 \frac{\text{m}}{\text{s}^2} \right) \\ = 530 \text{ kPa (76.9 psig)}$$

where:

P_{st} = static head, kPa (psig)

Step 2. The total discharge pressure at the pump exit is:

$$P = P_b + P_{st} \\ = 17.4 \text{ MPa} + 0.530 \text{ MPa} \\ = 17.9 \text{ MPa (2.600 psig)}$$

where:

P = total discharge pressure, MPa (psig)

P_b = back pressure, MPa (psig)

P_{st} = static head, MPa (psig)

⁵ ASME B31.3, pp. 13-14.

The design pressure for the 150 mm (6 in) header should be set slightly above the maximum operating pressure. Therefore the design pressure for the 150 mm (6 in) header is 18.3 MPa (2,650 psig).

$$S' = 1.20 (S) = 1.20 (121 \text{ MPa}) \\ = 145 \text{ MPa (21,000 psi)}$$

Step 3. Determination of design pressure for the 100 mm (4 in) pipe is as follows. The set pressure of the relief valve is 19.2 MPa (2,780 psig). The design pressure of the 100 mm (4 in) pipe upstream of the pump discharge valve should be set at the relief pressure of the relief valve. Although not shown in this example, the design pressure should also take into account any over-pressure allowance in the relief valve sizing determination. Therefore, for this example, the design pressure for the 100 mm (4 in) pipe upstream of the pump isolation valves is 19.2 MPa (2,780 psig).

where:

S' = higher allowable stress, MPa (psi)
S = code allowable stress, MPa (psi)

Step 6. The maximum pressure rating of the 100 mm (4 in) pipe is calculated using the following equation⁸:

$$P_{\max} = \frac{2 S E (t_m - A)}{D_o - 2 y (t_m - A)}$$

Step 4. The maximum allowable pressure in the 100 mm (4 in) pipe is compared to that which would be observed during relief valve failure. The probability that a valve will fail to open is low. It is recognized that variations in pressure and temperature inevitably occur.

where:

P_{max} = maximum allowable pressure, MPa (psig)
S = code allowable stress, MPa (psi)
E = joint efficiency
t_m = pipe wall thickness, mm (in)
A = corrosion allowance, mm (in)
D_o = outside diameter of pipe, mm (in)
y = temperature-based coefficient, see ASME B31.1, for cast iron, non-ferrous metals, and for ferric steels, austenitic steels and Ni alloys less than 482°C (900°F), y = - 0.4.

"102.2.4 Ratings: Allowance for Variation From Normal Operation. The maximum internal pressure and temperature allowed shall include considerations for occasional loads and transients of pressure and temperature."⁶

The calculated stress resulting from such a variation in pressure and/or temperature may exceed the maximum allowable stress from ASME B31.1 Appendix A by 15% if the event duration occurs less than 10% of any 24- hour operating period, or 20% if the event duration occurs less than 1% of any 24-hour operating period.⁷ The occasional load criteria of ASME B31.1, paragraph 102.2.4, is applied, and it is assumed that the relief valve failure-to-open event occurs less than 1% of the time. Therefore, the allowable stress is 20% higher than the basic code allowable stress of 121 MPa (17,500 psi).

Step 7. For this example, the value of S is set to equal to S' and E = 1.00 for seamless pipe. The pipe wall thickness is determined in accordance to pressure integrity, see Paragraph 3-3b, and is assumed equal to 87½% of the nominal wall thickness of schedule XXS pipe. Therefore:

$$t_m = 17.1 \text{ mm (0.875)} \\ = 15.0 \text{ mm (0.590 in)}$$

Step 5. The higher allowable stress is denoted as S':

where

t_m = pipe wall thickness, mm (in)

⁶ ASME B31.1, p. 13.

⁷ Ibid., p. 13.

⁸ Ibid., p. 17.

and

$$P_{\max} = \frac{2(145 \text{ MPa})(1.0)(15.0 \text{ mm} - 2 \text{ mm})}{114.3 \text{ mm} - 2(0.4)(15.0 \text{ mm} - 2 \text{ mm})}$$

$$= 36.3 \text{ MPa (5,265 psig)}$$

where:

P_{\max} = maximum allowable pressure, MPa (psig)

Step 8. Therefore, the maximum allowable pressure in the 100 mm (4 in) pipe section during a relief valve failure is 36.3 MPa (5,265 psig).

Another common transient pressure condition is caused by suddenly reducing the liquid flow in a pipe. When a valve is abruptly closed, dynamic energy is converted to elastic energy and a positive pressure wave is created upstream of the valve. This pressure wave travels at or near the speed of sound and has the potential to cause pipe failure. This phenomenon is called water hammer.

The maximum pressure rise is calculated by:

$$P_i = \rho \Delta V V_w n_1$$

where:

P_i = maximum pressure increase, MPa (psi)
 ρ = fluid density, kg/m³ (slugs/ft³)
 ΔV = sudden change in liquid velocity, m/s (ft/s)
 V_w = pressure wave velocity, m/s (ft/s)
 n_1 = conversion factor, 10⁻⁶ MPa/Pa for SI units (1 ft²/144 in² for IP units)

The maximum time of valve closure that is considered sudden (critical) is calculated by:

$$t_c = \frac{2L}{V_w}$$

where:

t_c = critical time, s
 L = length of pipe, m (ft)
 V_w = pressure wave velocity, m/s (ft/s)

The velocity of the pressure wave is affected by the fluid properties and by the elasticity of the pipe. The pressure wave velocity in water is approximately 1,480 m/s (4,800 ft/s). For a rigid pipe, the pressure wave velocity is calculated by:

$$V_w = \left(\frac{E_s}{n_1 \rho} \right)^{1/2}$$

where:

V_w = pressure wave velocity, m/s (ft/s)
 E_s = fluid's bulk modulus of elasticity, MPa (psi)
 ρ = fluid density, kg/m³ (slugs/ft³)
 n_1 = conversion factor, 10⁻⁶ MPa/Pa for SI units (1 ft²/144 in² for IP units)

Because of the potential expansion of an elastic pipe, the pressure wave for an elastic pipe is calculated by:

$$V_w = \left(\frac{E_s}{n_1 \rho \left(1 + \frac{E_s D_i}{E_p t} \right)} \right)^{1/2}$$

where:

V_w = pressure wave velocity, m/s (ft/s)
 E_s = fluid's bulk modulus of elasticity, MPa (psi)
 ρ = fluid density, kg/m³ (slugs/ft³)
 E_p = bulk modulus of elasticity for piping material, MPa (psi)
 D_i = inner pipe diameter, mm (in)
 t = pipe wall thickness, mm (in)
 n_1 = conversion factor, 10⁻⁶ MPa/Pa for SI units (1 ft²/144 in² for IP units)

If the valve is slowly closed (i.e., the time of closure is greater than the critical time), a series of small pressure waves is transmitted up the pipe and returning negative pressure waves will be superimposed on the small pressure waves and full pressure will not occur. The pressure developed by gradual closure of a valve is:

$$P'_i = \frac{2 \rho L V n_1}{t_v}$$

where:

- P'_1 = pressure increase, MPa (psi)
- t_v = valve closure time
- ρ = fluid density, kg/m³ (slugs/ft³)
- L = length of pipe, m (ft)
- V = liquid velocity, m/s (ft/s)
- n_1 = conversion factor, 10⁻⁶ MPa/Pa for SI units (1 ft²/144 in² for IP units)

$$V_w = \left(\frac{2,180 \text{ MPa}}{(10^{-6} \text{ MPa/Pa}) (998.2 \text{ kg/m}^3)} \right)^{1/2}$$

$$= 1,478 \text{ m/s (4,848 ft/s)}$$

CECER has a computer program, WHAMO, designed to simulate water hammer and mass oscillation in pumping facilities. The program determines time varying flow and head in a piping network which may include valves, pumps, turbines, surge tanks and junctions arranged in a reasonable configuration. Transients are generated in the program due to any variation in the operation of pumps, valves, and turbines, or in changes in head.

Example Problem 3:

Water at 20°C (68°F) flows from a tank at a velocity of 3 m/s (9.8 ft/s) and an initial pressure of 275 kPa (40 psi) in a 50 mm (2 in) PVC pipe rated for 16 kgf/cm² (SDR 26); i.e., wall thickness is 4.7 mm (0.091 in for SDR 26). A valve 150 m (492 ft) downstream is closed. Determine the critical time of closure for the valve and the internal system pressure if the valve is closed suddenly versus gradually (10 times slower).

Solution:

Step 1. Velocity of the pressure wave assuming rigid pipe;

$$V_w = \left(\frac{E_s}{n_1 \rho} \right)^{1/2}$$

where:

- V_w = pressure wave velocity, m/s (ft/s)
- E_s = fluid's bulk modulus of elasticity; for water at 20°C (68°F) = 2,180 MPa (319,000 psi)
- n_1 = conversion factor, 10⁻⁶ MPa/Pa for SI units (1 ft²/144 in² for IP units)
- ρ = fluid density, for water at 20°C (68°F) = 998.2 kg/m³ (1.937 slugs/ft³)

Step 2. Critical time for valve closure;

$$t_c = \frac{2L}{V_w} = \frac{2(150 \text{ m})}{1,478 \text{ m/s}}$$

$$= 0.2 \text{ s}$$

where:

- t_c = critical time, s
- L = Length of pipe, m (ft)
- V_w = pressure wave velocity, m/s (ft/s)

Step 3. Maximum pressure rise (valve closure time < critical time, t_c);

$$P_i = \rho \Delta V V_w n_1$$

where:

- P_i = maximum pressure increase, MPa (psi)
- ρ = fluid density, kg/m³ (slugs/ft³)
- ΔV = sudden change in liquid velocity, m/s (ft/s)
- V_w = pressure wave velocity, m/s (ft/s)
- n_1 = conversion factor, 10⁻⁶ MPa/Pa for SI units (1 ft²/144 in² for IP units)

$$P_i = \left(998.2 \frac{\text{kg}}{\text{m}^3} \right) \left(3 \frac{\text{m}}{\text{s}} \right) \left(1,478 \frac{\text{m}}{\text{s}} \right) \left(10^{-6} \frac{\text{MPa}}{\text{Pa}} \right)$$

$$= 4.43 \text{ MPa (642 psi)}$$

Therefore, maximum system pressure is

$$P_{\text{max}} = 4.43 \text{ MPa} + 275 \text{ kPa (} 10^{-3} \text{ MPa/kPa)}$$

$$= 4.71 \text{ MPa (682 psig)}$$

Step 4. Pressure increase with gradual valve closure
(valve closure time = critical time, t_c , $\times 10 = 2s$)

$$P'_i = \frac{2 \rho L V n_1}{t_v}$$

where:

- P'_i = pressure increase, MPa (psi)
- t_v = valve closure time
- ρ = fluid density, kg/m^3 (slugs/ ft^3)
- L = length of pipe, m (ft)
- V = liquid velocity, m/s (ft/s)
- n_1 = conversion factor, 10^{-6} MPa/Pa for SI units (1 $\text{ft}^2/144$ in^2 for IP units)

$$P'_i = \frac{2 \left(998.2 \frac{\text{kg}}{\text{m}^3} \right) (150\text{m}) \left(3 \frac{\text{m}}{\text{s}} \right)}{2 \text{ s}} \left(10^{-3} \frac{\text{kPa}}{\text{Pa}} \right)$$

$$= 449 \text{ kPa (65 psi)}$$

Therefore, the maximum system pressure is 449 kPa + 275 kPa = 724 kPa (105 psig).

For a more complex review of water hammer effects in pipes, refer to the references found in Appendix A, Paragraph A-4.

3-3. Sizing

The sizing for any piping system consists of two basic components fluid flow design and pressure integrity design. Fluid flow design determines the minimum acceptable diameter of the piping necessary to transfer the fluid efficiently. Pressure integrity design determines the minimum pipe wall thickness necessary to safely handle the expected internal and external pressure and loads.

a. Fluid Flow Sizing

The primary elements in determining the minimum acceptable diameter of any pipe network are system design flow rates and pressure drops. The design flow rates are based on system demands that are normally established in the process design phase of a project.

Before the determination of the minimum inside diameter can be made, service conditions must be reviewed to determine operational requirements such as recommended fluid velocity for the application and liquid characteristics such as viscosity, temperature, suspended solids concentration, solids density and settling velocity, abrasiveness and corrosivity. This information is then used to determine the minimum inside diameter of the pipe for the network.

For normal liquid service applications, the acceptable velocity in pipes is 2.1 ± 0.9 m/s (7 ± 3 ft/s) with a maximum velocity limited to 2.1 m/s (7 ft/s) at piping discharge points including pump suction lines and drains. As stated, this velocity range is considered reasonable for normal applications. However, other limiting criteria such as potential for erosion or pressure transient conditions may overrule. In addition, other applications may allow greater velocities based on general industry practices; e.g., boiler feed water and petroleum liquids.

Pressure drops throughout the piping network are designed to provide an optimum balance between the installed cost of the piping system and operating costs of the system pumps. Primary factors that will impact these costs and system operating performance are internal pipe diameter (and the resulting fluid velocity), materials of construction and pipe routing.

Pressure drop, or head loss, is caused by friction between the pipe wall and the fluid, and by minor losses such as flow obstructions, changes in direction, changes in flow area, etc. Fluid head loss is added to elevation changes to determine pump requirements.

A common method for calculating pressure drop is the Darcy-Weisbach equation:

$$h_L = \left(\frac{fL}{D_i} + \Sigma K \right) \frac{V^2}{2g}; \text{ loss coefficient method}$$

or

$$h_L = f \frac{(L + L_e)}{D_i} \frac{V^2}{2g}; \text{ equivalent length method}$$

where:

- h_L = head loss, m (ft)
- f = friction factor
- L = length of pipe, m (ft)
- D_i = inside pipe diameter, m (ft)
- L_e = equivalent length of pipe for minor losses, m (ft)
- K = loss coefficients for minor losses
- V = fluid velocity, m/s (ft/sec)
- g = gravitational acceleration, 9.81 m/sec² (32.2 ft/sec²)

The friction factor, f , is a function of the relative roughness of the piping material and the Reynolds number, R_e .

$$R_e = \frac{D_i V}{\nu}$$

where:

- R_e = Reynolds number
- D_i = inside pipe diameter, m (ft)
- V = fluid velocity, m/s (ft/s)
- ν = kinematic viscosity, m²/s (ft²/s)

If the flow is laminar ($R_e < 2,100$), then f is determined by:

$$f = \frac{64}{R_e}$$

where:

- f = friction factor
- R_e = Reynolds number

If the flow is transitional or turbulent ($R_e > 2,100$), then f is determined from the Moody Diagram, see Figure 3-1. The appropriate roughness curve on the diagram is determined by the ratio ϵ/D_i where ϵ is the specific surface roughness for the piping material (see Table 3-1) and D_i is the inside pipe diameter.

The method of equivalent lengths accounts for minor losses by converting each valve and fitting to the length of straight pipe whose friction loss equals the minor loss. The equivalent lengths vary by materials, manufacturer and size (see Table 3-2). The other method uses loss coefficients. This method must be used to calculate exit

and entrance losses. The coefficients can be determined from Table 3-3.

Another method for calculating pressure drop is the Hazen-Williams formula:

$$h_L = (L + L_e) \left(\frac{V}{a C (D_i/4)^{0.63}} \right)^{1.85}$$

where:

- h_L = head loss, m (ft)
- L = length of pipe, m (ft)
- L_e = equivalent length of pipe for minor losses, m (ft)
- V = fluid velocity, m/s (ft/s)
- a = empirical constant, 0.85 for SI units (1.318 for IP units)
- C = Hazen-Williams coefficient
- D_i = inside pipe diameter, m (ft)

The Hazen-Williams formula is empirically derived and is limited to use with fluids that have a kinematic viscosity of approximately 1.12×10^{-6} m²/s (1.22×10^{-5} ft²/s), which corresponds to water at 15.6°C (60°F), and for turbulent flow. Deviations from these conditions can lead to significant error. The Hazen-Williams coefficient, C , is independent of the Reynolds number. Table 3-1 provides values of C for various pipe materials.

The Chezy-Manning equation is occasionally applied to full pipe flow. The use of this equation requires turbulent flow and an accurate estimate of the Manning factor, n , which varies by material and increases with increasing pipe size. Table 3-1 provides values of n for various pipe materials. The Chezy-Manning equation is:

$$h_L = \frac{V^2 n^2}{a (D_i/4)^{4/3}} (L + L_e)$$

where:

- h_L = head loss, m (ft)
- V = fluid velocity, m/s (ft/s)
- n = Manning factor
- a = empirical constant, 1.0 for SI units (2.22 for IP units)

Table 3-1 Pipe Material Roughness Coefficients			
Pipe Material	Specific Roughness Factor, ϵ , mm (in)	Hazen-Williams Coefficient, C	Manning Factor, n
Steel, welded and seamless	0.061 (0.0002)	140	
Ductile Iron	0.061 (0.0002)	130	
Ductile Iron, asphalt coated	0.12 (0.0004)	130	0.013
Copper and Brass	0.61 (0.002)	140	0.010
Glass	0.0015 (0.000005)	140	
Thermoplastics	0.0015 (0.000005)	140	
Drawn Tubing	0.0015 (0.000005)		
Sources: Hydraulic Institute, <u>Engineering Data Book</u> , Various vendor data compiled by SAIC, 1998.			

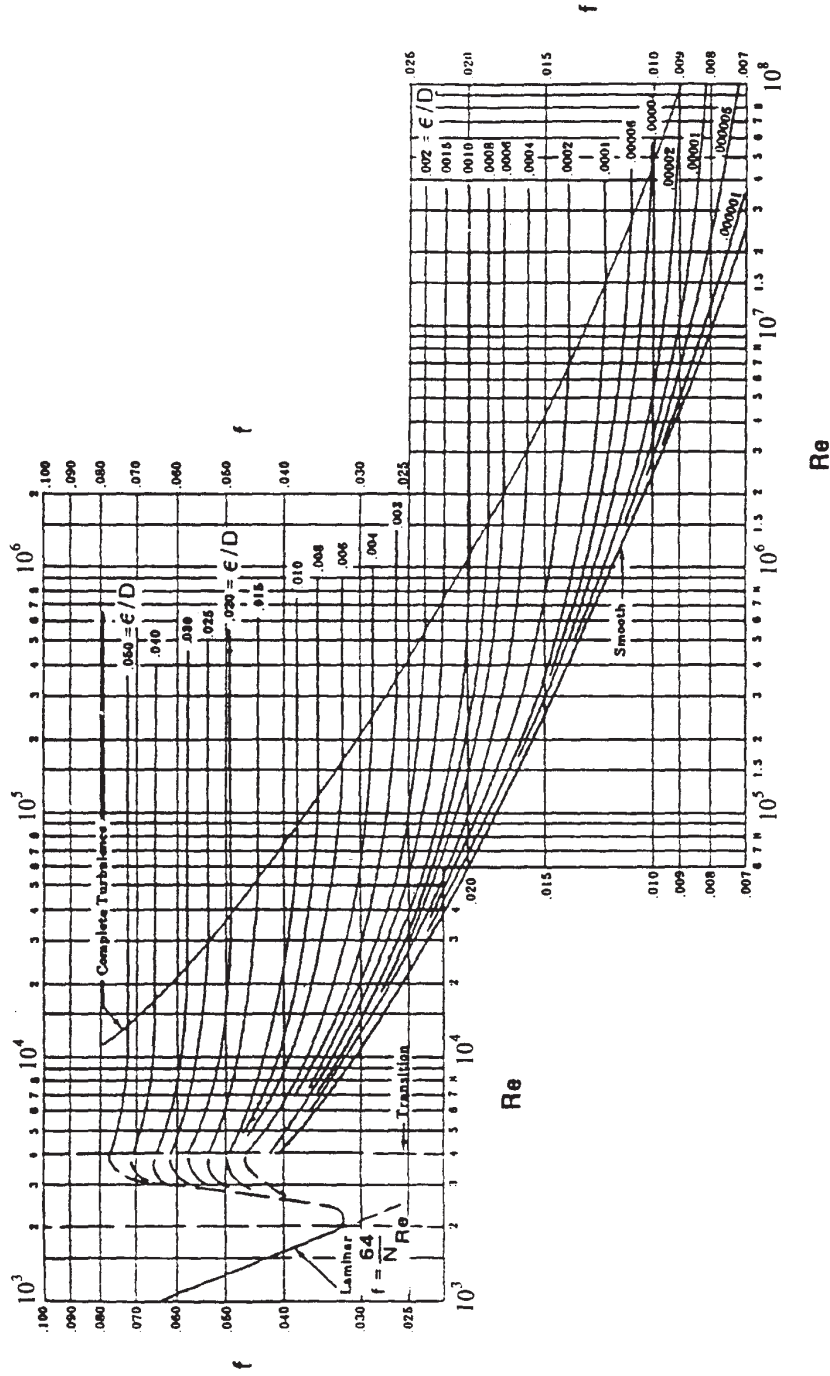

Figure 3-1. Moody Diagram
 (Source: L.F. Moody, "Friction Factors for Pipe Flow," Transactions of the ASME, Vol. 66, Nov. 1944, pp. 671-678, Reprinted by permission of ASME.)

Table 3-2 Estimated Pressure Drop for Thermoplastic Lined Fittings and Valves							
Size mm (in)	Standard 90° elbow	Standard tee		Plug Valve	Diaphragm Valve	Vertical Check Valve	Horizontal Check Valve
		Through run	Through branch				
25 (1)	0.55 (1.8)	0.37 (1.2)	1.4 (4.5)	0.61 (2.0)	2.1 (7)	1.8 (6.0)	4.9 (16)
40 (1½)	1.1 (3.5)	0.70 (2.3)	2.3 (7.5)	1.3 (4.2)	3.0 (10)	1.8 (6.0)	7.0 (23)
50 (2)	1.4 (4.5)	0.91(3.0)	3.0 (10)	1.7 (5.5)	4.9 (16)	3.0 (10)	14 (45)
65 (2½)	1.7 (5.5)	1.2 (4.0)	3.7 (12)	N.A.	6.7 (22)	3.4 (11)	15 (50)
80 (3)	2.1 (7.0)	1.2 (4.1)	4.6 (15)	N.A.	10 (33)	3.7 (12)	18 (58)
100 (4)	3.0 (10)	1.8 (6.0)	6.1 (20)	N.A.	21 (68)	6.1 (20)	20 (65)
150 (6)	4.6 (15)	3.0 (10)	9.8 (32)	N.A.	26 (85)	9.4 (31)	46 (150)
200 (8)	5.8 (19)	4.3 (14)	13 (42)	N.A.	46 (150)	23 (77)	61 (200)
250 (10)	7.6 (25)	5.8 (19)	16 (53)	N.A.	N.A.	N.A.	N.A.
300 (12)	9.1 (30)	7.0 (23)	20 (64)	N.A.	N.A.	N.A.	N.A.

Notes:
 Data is for water expressed as equal length of straight pipe in m (ft)
 N.A. = Part is not available from source.
 Source:
 “Plastic Lined Piping Products Engineering Manual”, p. 48.

**Table 3-3
Minor Loss Coefficients (K)**

Minor loss	Description	K
Pipe Entrance	sharp edged	0.5
	inward projected pipe	1.0
	rounded	0.05
Pipe Exit	all	1.0
Contractions	sudden	$0.5 [1 - (\beta^2)^2]$
	gradual, $\phi < 22^\circ$	$0.8 (\sin \phi) (1 - \beta^2)$
	gradual, $\phi > 22^\circ$	$0.5 (\sin \phi)^{0.5} (1 - \beta^2)$
Enlargements	sudden	$[1 - (\beta^2)^2]^2$
	gradual, $\phi < 22^\circ$	$2.6 (\sin \phi) (1 - \beta^2)^2$
	gradual, $\phi > 22^\circ$	$(1 - \beta^2)^2$
Bends	90° standard elbow	0.9
	45° standard elbow	0.5
Tee	standard, flow through run	0.6
	standard, flow through branch	1.8
Valves	globe, fully open	10
	angle, fully open	4.4
	gate, fully open	0.2
	gate, ½ open	5.6
	ball, fully open	4.5
	butterfly, fully open	0.6
	swing check, fully open	2.5
<p>Notes: ϕ = angle of convergence/divergence β = ratio of small to large diameter</p> <p>Sources: Hydraulic Institute, "Pipe Friction Manual, 3rd Ed. Valve data from Crane Company, "Flow of Fluids," Technical Paper 410; reprinted by permission of the Crane Valve Group.</p>		

D_i = inside pipe diameter, m (ft)
 L = length of pipe, m (ft)
 L_e = equivalent length of pipe for minor losses, m (ft)

It is common practice in design to use higher values of ϵ and n and lower values of C than are tabulated for new pipe in order to allow for capacity loss with time.

Example Problem 4:

An equalization tank containing water with dissolved metals is to be connected to a process tank via above grade piping. A pump is required because the process tank liquid elevation is 30 m (98.4 ft) above the equalization tank level.

The piping layout indicates that the piping system requires:

- 2 isolation valves (gate);
- 1 swing check valve;
- 5 standard 90° elbows; and
- 65 m (213.5 ft) of piping.

The process conditions are:

- $T = 25^\circ\text{C}$ (77°F); and
- $Q = 0.05 \text{ m}^3/\text{s}$ ($1.77 \text{ ft}^3/\text{s}$).

The required piping material is PVC. The design program now requires the pipe to be sized and the pressure drop in the line to be determined in order to select the pump.

Solution:

Step 1. Select pipe size by dividing the volumetric flow rate by the desired velocity (normal service, $V = 2.1 \text{ m/s}$).

$$A = \pi \frac{D_i^2}{4} = \frac{Q}{V}$$

$$D_i = \left[\frac{4}{\pi} \frac{0.05 \text{ m}^3/\text{s}}{2.1 \text{ m/s}} \right]^{0.5} \left(1000 \frac{\text{mm}}{\text{m}} \right)$$

$$= 174 \text{ mm (6.85 in)}$$

Step 2. From Table 1-1, select 150 mm (6 in) as the actual pipe size and calculate actual velocity in the pipe.

$$\begin{aligned}
 V &= \frac{Q}{A} = \frac{Q}{\frac{\pi}{4} D_i^2} \\
 &= \frac{0.05 \text{ m}^3/\text{s}}{\frac{\pi}{4} (0.150 \text{ m})^2} \\
 &= 2.83 \text{ m/s (9.29 ft/s)}
 \end{aligned}$$

Step 3. At 25°C , $\nu = 8.94 \times 10^{-7} \text{ m}^2/\text{s}$. So the Darcy-Weisbach equation is used to calculate the pressure drop through the piping.

$$h_L = \left(\frac{fL}{D_i} + \Sigma K \right) \frac{V^2}{2g}$$

Step 4. Determine the friction factor, f , from the Moody Diagram (Figure 3-1) and the following values.

$$\begin{aligned}
 R_e &= \frac{D_i V}{\nu} = \frac{(0.150 \text{ m})(2.83 \text{ m/s})}{8.94 \times 10^{-7} \text{ m}^2/\text{s}} \\
 &= 4.75 \times 10^5 - \text{turbulent flow}
 \end{aligned}$$

$$\epsilon = 1.5 \times 10^{-6} \text{ m from Table 3-1}$$

$$\epsilon/D_i = \frac{1.5 \times 10^{-6} \text{ m}}{0.150 \text{ m}} = 0.00001;$$

therefore, $f = 0.022$ from Figure 3-1.

Step 5. Determine the sum of the minor loss coefficients from Table 3-3:

<u>minor loss</u>	<u>K</u>
entry	0.5
2 gate valves	0.2x2
check valve	2.5
5 elbows	0.35x5
<u>exit</u>	<u>1.0</u>
sum	6.15

Step 6. Calculate the head loss.

$$h_L = \left(\frac{fL}{D_i} + \Sigma K \right) \frac{V^2}{2g}$$

$$= \left[\frac{(0.022)(65 \text{ m})}{0.150 \text{ m}} + 5.15 \right] \frac{(2.83 \text{ m/s})^2}{2 (9.81 \text{ m/s}^2)}$$

$$= 6.4 \text{ m (21 ft)}$$

Step 7. The required pump head is equal to the sum of the elevation change and the piping pressure drop.

$$P_{head} = 30 \text{ m} + 6.4 \text{ m} = 36.4 \text{ m}$$

The prediction of pressures and pressure drops in a pipe network are usually solved by methods of successive approximation. This is routinely performed by computer applications now. In pipe networks, two conditions must be satisfied: continuity must be satisfied (the flow entering a junction equals the flow out of the junction); and there can be no discontinuity in pressure (the pressure drop between two junctions are the same regardless of the route).

The most common procedure in analyzing pipe networks is the Hardy Cross method. This procedure requires the flow in each pipe to be assumed so that condition 1 is satisfied. Head losses in each closed loop are calculated and then corrections to the flows are applied successively until condition 2 is satisfied within an acceptable margin.

b. Pressure Integrity

The previous design steps have concentrated on the evaluation of the pressure and temperature design bases and the design flow rate of the piping system. Once the

system operating conditions have been established, the minimum wall thickness is determined based on the pressure integrity requirements.

The design process for consideration of pressure integrity uses allowable stresses, thickness allowances based on system requirements and manufacturing wall thickness tolerances to determine minimum wall thickness.

Allowable stress values for metallic pipe materials are generally contained in applicable design codes. The codes must be utilized to determine the allowable stress based on the requirements of the application and the material to be specified.

For piping materials that are not specifically listed in an applicable code, the allowable stress determination is based on applicable code references and good engineering design. For example, design references that address this type of allowable stress determination are contained in ASME B31.3 Sec. 302.3.2. These requirements address the use of cast iron, malleable iron, and other materials not specifically listed by the ASME B31.3.

After the allowable stress has been established for the application, the minimum pipe wall thickness required for pressure integrity is determined. For straight metallic pipe, this determination can be made using the requirements of ASME B31.3 Sec. 304 or other applicable codes. The determination of the minimum pipe wall thickness using the ASME B31.3 procedure is described below (see code for additional information). The procedure and following example described for the determination of minimum wall thickness using codes other than ASME B31.3 are similar and typically follow the same overall approach.

$$t_m = t + A$$

where:

t_m = total minimum wall thickness required for pressure integrity, mm (in)

t = pressure design thickness, mm (in)

A = sum of mechanical allowances plus corrosion allowance plus erosion allowance, mm (in)

Allowances include thickness due to joining methods, corrosion/erosion, and unusual external loads. Some methods of joining pipe sections result in the reduction of wall thickness. Joining methods that will require this allowance include threading, grooving, and swagging. Anticipated thinning of the material due to effects of corrosion or mechanical wear over the design service life of the pipe may occur for some applications. Finally, site-specific conditions may require additional strength to account for external operating loads (thickness allowance for mechanical strength due to external loads). The stress associated with these loads should be considered in conjunction with the stress associated with the pressure integrity of the pipe. The greatest wall thickness requirement, based on either pressure integrity or external loading, will govern the final wall thickness specified. Paragraph 3-4 details stress analyses.

Using information on liquid characteristics, the amount of corrosion and erosion allowance necessary for various materials of construction can be determined to ensure reasonable service life. Additional information concerning the determination of acceptable corrosion resistance and material allowances for various categories of fluids is contained in Paragraph 3-1a.

The overall formula used by ASME B31.3 for pressure design minimum thickness determination (t) is:

$$t = \frac{P D_o}{2 (S E + P y)}$$

where:

- P = design pressure, MPa (psi)
- D_o = outside diameter of the pipe, mm (in)
- S = allowable stress, see Table A-1 from ASME B31.3, MPa (psi)
- E = weld joint efficiency or quality factor, see Table A-1A or Table A-1B from ASME B31.3
- y = dimensionless constant which varies with temperature, determined as follows:
 For $t < D_o/6$, see table 304.1.1 from ASME B31.3 for values of y
 For $t \geq D_o/6$ or $P/SE > 0.385$, then a special consideration of failure theory, fatigue and thermal stress may be required or ASME B31.3 also allows the use of the following equation to calculate y:

$$y = \frac{D_i + 2A}{D_o + D_i + 2A}$$

where:

- D_i = inside diameter of the pipe, mm (in)
- D_o = outside diameter of the pipe, mm (in)
- A = sum of mechanical allowances plus corrosion allowance plus erosion allowance, mm (in)

Example Problem 5:

In order to better illustrate the process for the determination of the minimum wall thickness, the example in Paragraph 3-2b will be used to determine the wall thickness of the two pipes. For the 150 mm (6 in) header, the values of the variables are:

- P = 18.3 MPa (2650 psig)
- D_o = 160 mm (6.299 in)
- S = 121 MPa (17,500 psi)
- Assume $t < 12.75$ in/6, so $y = 0.4$ from ASME B31.3
- A = 2 mm (0.08 in)
- E = 1.0

Solution:

Step 1. Determine the minimum wall thickness.

$$t_m = t + A$$

$$t = \frac{P D_o}{2 (S E + P y)}$$

Therefore,

$$\begin{aligned} t_m &= \frac{P D_o}{2 (S E + P y)} + A \\ &= \frac{(18.3 \text{ MPa})(160 \text{ mm})}{2[(121 \text{ MPa})(1.0) + (18.3 \text{ MPa})(0.4)]} \\ &\quad + 2 \text{ mm} \\ &= 13.4 \text{ mm (0.528 in)} \end{aligned}$$

Step 2. The commercial wall thickness tolerance for seamless rolled pipe is +0, -12½%; therefore, to determine the nominal wall thickness, the minimum wall thickness is divided by the smallest possible thickness allowed by the manufacturing tolerances.

$$t_{NOM} = \frac{13.4 \text{ mm}}{1.0 - 0.125} = 15.3 \text{ mm (0.603 in)}$$

Step 3. Select a commercially available pipe by referring to a commercial specification. For U.S. work ANSI B36.10M/B36.10 is used commercially; the nearest commercial 150 mm (6 in) pipe whose wall thickness exceeds 15.3 mm (0.603 in) is Schedule 160 with a nominal wall thickness of 18.3 mm (0.719 in). Therefore, 150 mm (6 in) Schedule 160 pipe meeting the requirements of ASTM A 106 Grade C is chosen for this application. This calculation does not consider the effects of bending. If bending loads are present, the required wall thickness may increase.

Step 4. For the 100 mm (4 in) header, the outside diameter of 100 mm (4 in) pipe = 110 mm (4.331 in). Therefore:

$$t_m = \frac{P D_o}{2 (S E + P y)} + A$$

$$= \frac{(19.2 \text{ MPa})(110 \text{ mm})}{2[(121 \text{ MPa})(1.0) + (19.2 \text{ MPa})(0.4)]}$$

$$+ 2 \text{ mm}$$

$$= 10.2 \text{ mm (0.402 in)}$$

$$t_{NOM} = \frac{10.2 \text{ mm}}{1.0 - 0.125} = 11.7 \text{ mm (0.459 in)}$$

The required nominal wall thickness is 11.7 mm (0.459 in).

Step 5. Select a commercially available pipe by referring to a commercial standard. Using ANSI B36.10M/B36.10, XXS pipe with a nominal wall thickness of 17.1 mm (0.674 in) is selected.

Step 6. Check whether the wall thickness for the selected 100 mm (4 in) schedule XXS pipe is adequate to withstand a relief valve failure. The shutoff head of the pump was given as 2,350 m (7,710 ft), and the specific volume of pressurized water at 177°C (350°F) was previously determined to be 0.001110 m³/kg (0.01778 ft³/lbm). The pressure equivalent to the shutoff head may be calculated based upon this specific volume.

$$P = (2,350 \text{ m}) \left(\frac{1}{0.001110 \frac{\text{m}^3}{\text{kg}}} \right) \left(9.81 \frac{\text{m}}{\text{s}^2} \right)$$

$$= 20.8 \text{ MPa (3,020 psig)}$$

Step 7. Since the previously determined maximum allowable pressure 36.3 MPa (5,265 psig) rating of the XXS pipe exceeds the 20.8 MPa (3,020 psig) shutoff head of the pump, the piping is adequate for the intended service.

The design procedures presented in the forgoing problem are valid for steel or other code-approved wrought materials. They would not be valid for cast iron or ductile iron piping and fittings. For piping design procedures which are suitable for use with cast iron or ductile iron pipe, see ASME B31.1, paragraph 104.1.2(b).

3-4. Stress Analysis

After piping materials, design pressure and sizes have been selected, a stress analysis is performed that relates the selected piping system to the piping layout (Paragraph 2-6) and piping supports (Paragraph 3-7). The analysis ensures that the piping system meets intended service and loading condition requirements while optimizing the layout and support design. The analysis may result in successive reiterations until a balance is struck between stresses and layout efficiency, and stresses and support locations and types. The stress analysis can be a simplified analysis or a computerized analysis depending upon system complexity and the design code.

a. Code Requirements

Many ASME and ANSI codes contain the reference data, formulae, and acceptability limits required for the stress analysis of different pressure piping systems and services. ASME B31.3 requires the analysis of three stress limits: stresses due to sustained loads, stresses due to displacement strains, and stresses due to occasional loads. Although not addressed by code, another effect resulting from stresses that is examined is fatigue.

b. Stresses due to Sustained Loads

The stress analysis for sustained loads includes internal pressure stresses, external pressure stresses and longitudinal stresses. ASME B31.3 considers stresses due to internal and external pressures to be safe if the wall thickness meets the pressure integrity requirements (Paragraph 3-3b). The sum of the longitudinal stresses in the piping system that result from pressure, weight and any other sustained loads do not exceed the basic allowable stress at the maximum metal temperature.

$$\Sigma S_L \leq S_h$$

where:

- S_L = longitudinal stress, MPa (psi)
- S_h = basic allowable stress at maximum material temperature, MPa (psi), from code (ASME B31.3 Appendix A).

The internal pressure in piping normally produces stresses in the pipe wall because the pressure forces are offset by pipe wall tension. The exception is due to pressure transients such as water hammer which add load to pipe supports. The longitudinal stress from pressure is calculated by:

$$S_L = \frac{P D_o}{4 t}$$

where:

- S_L = longitudinal stress, MPa (psi)
- P = internal design pressure, MPa (psi)
- D_o = outside pipe diameter, mm (in)
- t = pipe wall thickness, mm (in)

The longitudinal stress due to weight is dependent upon support locations and pipe spans. A simplified method to calculate the pipe stress is:

$$S_L = 0.1 \frac{W L^2}{n Z}$$

where:

- S_L = longitudinal stress, MPa (psi)
- W = distributed weight of pipe material, contents and insulation, N/m (lbs/ft)
- L = pipe span, m (ft)
- n = conversion factor, 10^{-3} m/mm (1 ft/12 in)
- Z = pipe section modulus, mm^3 (in^3)

$$Z = \frac{\pi}{32} \frac{D_o^4 - D_i^4}{D_o}$$

where:

- D_o = outer pipe diameter, mm (in)
- D_i = inner pipe diameter, mm (in)

c. Stresses due to Displacement Strains

Constraint of piping displacements resulting from thermal expansion, seismic activities or piping support and terminal movements cause local stress conditions. These localized conditions can cause failure of piping or supports from fatigue or over-stress, leakage at joints or distortions. To ensure that piping systems have sufficient flexibility to prevent these failures, ASME B31.3 requires that the displacement stress range does not exceed the allowable displacement stress range.

$$S_E \leq S_A$$

where:

- S_E = displacement stress range, MPa (psi)
- S_A = allowable displacement stress range, MPa (psi)

$$S_A = f [1.25 (S_c + S_h) - S_L]$$

where:

S_A = allowable displacement stress range, MPa (psi)

f = stress reduction factor

S_c = basic allowable stress of minimum material temperature, MPa (psi), from code (ASME B31.3 Appendix A)

S_h = basic allowable stress at maximum material temperature, MPa (psi), from code (ASME B31.3 Appendix A)

S_L = longitudinal stress, MPa (psi)

$$f = 6.0 (N)^{-0.2} \leq 1.0$$

$$Z = \frac{\pi}{32} \frac{D_o^4 - D_i^4}{D_o}$$

where:

D_o = outer pipe diameter, mm (in)

D_i = inner pipe diameter, mm (in)

$$S_t = \frac{M_t}{2 Z n}$$

where:

f = stress reduction factor

N = equivalent number of full displacement cycles during the expected service life, $< 2 \times 10^6$.

$$S_E = (S_b^2 + 4S_t^2)^{0.5}$$

where:

S_t = torsional stress, MPa (psi)

M_t = torsional moment, N-m (lb-ft)

Z = section modulus, mm^3 (in^3)

n = conversion factor, 10^{-3}m/mm (1 ft/12 in)

A formal flexibility analysis is not required when: (1) the new piping system replaces in kind, or without significant change, a system with a successful service record; (2) the new piping system can be readily judged adequate by comparison to previously analyzed systems; and (3) the new piping system is of uniform size, has 2 or less fixed points, has no intermediate restraints, and meets the following empirical condition.⁹

where:

S_E = displacement stress range, MPa (psi)

S_b = resultant bending stress, MPa (psi)

S_t = torsional stress, MPa (psi)

$$S_b = \frac{[(i_i M_i)^2 + (i_o M_o)^2]^{0.5}}{n Z}$$

$$\frac{D_o Y}{(L - L_s)^2} \leq K_1$$

where:

S_b = resultant bending stress, MPa (psi)

i_i = in plane stress intensity factor (see Table in code, ASME B31.3 Appendix D)

M_i = in plane bending moment, N-m (lb-ft)

i_o = out plane stress intensity factor (see table in code, ASME B31.3 Appendix D)

M_o = out plane bending moment, N-m (lb-ft)

n = conversion factor, 10^{-3}m/mm (1 ft/12 in)

Z = Section modulus, mm^3 (in^3)

where:

D_o = outside pipe diameter, mm (in)

Y = resultant of total displacement strains, mm (in)

L = length of piping between anchors, m (ft)

L_s = straight line distance between anchors, m (ft)

K_1 = constant, 208.3 for SI units (0.03 for IP units)

d. Stresses due to Occasional Loads

The sum of the longitudinal stresses due to both sustained and occasional loads does not exceed 1.33 times the basic allowable stress at maximum material temperature.

⁹ ASME B31.3, p. 38.

$$\Sigma S'_L \leq 1.33 S_h$$

where:

S'_L = longitudinal stress from sustained and occasional loads, MPa (psi)

S_h = basic allowable stress at maximum material temperature, MPa (psi), from code (ASME B31.3 Appendix A)

The longitudinal stress resulting from sustained loads is as discussed in Paragraph 3-4b. The occasional loads that are analyzed include seismic, wind, snow and ice, and dynamic loads. ASME B31.3 states that seismic and wind loads do not have to be considered as acting simultaneously.

e. Fatigue

Fatigue resistance is the ability to resist crack initiation and expansion under repeated cyclic loading. A material's fatigue resistance at an applied load is dependent upon many variables including strength, ductility, surface finish, product form, residual stress, and grain orientation.

Piping systems are normally subject to low cycle fatigue, where applied loading cycles rarely exceed 10^5 . Failure from low cycle fatigue is prevented in design by ensuring that the predicted number of load cycles for system life is less than the number allowed on a fatigue curve, or S-N curve, which correlates applied stress with cycles to failure for a material. Because piping systems are generally subject to varying operating conditions that may subject the piping to stresses that have significantly different magnitudes, the following method can be used to combine the varying fatigue effects.

$$U = \Sigma \frac{n_i}{N_i}$$

$$U < 1.0$$

where:

U = cumulative usage factor

n_i = number of cycles operating at stress level i

N_i = number of cycles to failure at stress level i as

per fatigue curve.

The assumption is made that fatigue damage will occur when the cumulative usage factor equals 1.0.

3-5. Flange, Gaskets and Bolting Materials

ANSI, in association with other technical organizations such as the ASME, has developed a number of predetermined pressure-temperature ratings and standards for piping components. Pipe flanges and flanged fittings are typically specified and designed to ASME B16.5 for most liquid process piping materials. The primary exception to this is ductile iron piping, which is normally specified and designed to AWWA standards. The use of other ASME pressure-integrity standards generally conforms to the procedures described below.

a. Flanges

Seven pressure classes -- 150, 300, 400, 600, 900, 1,500 and 2500 -- are provided for flanges in ASME B16.5. The ratings are presented in a matrix format for 33 material groups, with pressure ratings and maximum working temperatures. To determine the required pressure class for a flange:

Step 1. Determine the maximum operating pressure and temperature.

Step 2. Refer to the pressure rating table for the piping material group, and start at the class 150 column at the temperature rating that is the next highest above the maximum operating temperature.

Step 3. Proceed through the table columns on the selected temperature row until a pressure rating is reached that exceeds the maximum operating pressure.

Step 4. The column label at which the maximum operating pressure is exceeded at a temperature equal to or above the maximum operating temperature is the required pressure class for the flange.

Example Problem 6:

A nickel pipe, alloy 200, is required to operate at a maximum pressure of 2.75 MPa (399 psi) and 50°C (122°F).

Solution:

Nickel alloy 200 forged fitting materials are manufactured in accordance with ASTM B 160 grade

N02200 which is an ASME B16.5 material group 3.2. Entering Table 2-3.2 in ASME B16.5 at 200 degrees F, the next temperature rating above 50 °C (122 °F), a class 400 flange is found to have a 3.31 MPa (480 psi) rating and is therefore suitable for the operating conditions.

Care should be taken when mating flanges conforming to AWWA C110 with flanges that are specified using ASME B16.1 or B16.5 standards. For example, C110 flanges rated for 1.72 MPa (250 psi) have facing and drilling identical to B16.1 class 125 and B16.5 class 150 flanges; however, C110 flanges rated for 1.72 MPa (250 psi) will not mate with B16.1 class 250 flanges.¹⁰

b. Gaskets

Gaskets and seals are carefully selected to insure a leak-free system. A wide variety of gasket materials are available including different metallic and elastomeric products. Two primary parameters are considered, sealing force and compatibility. The force that is required at this interface is supplied by gasket manufacturers. Leakage will occur unless the gasket fills into and seals off all imperfections.

The metallic or elastomeric material used is compatible with all corrosive liquid or material to be contacted and is resistant to temperature degradation.

Gaskets may be composed of either metallic or nonmetallic materials. Metallic gaskets are commonly designed to ASME B16.20 and nonmetallic gaskets to ASME B16.21. Actual dimensions of the gaskets should be selected based on the type of gasket and its density, flexibility, resistance to the fluid, temperature limitation, and necessity for compression on its inner diameter, outer diameter or both. Gasket widths are commonly classified as group I (slip-on flange with raised face), group II (large tongue), or group III (small tongue width). Typically, a more narrow gasket face is used to obtain higher unit compression, thereby allowing reduced bolt loads and flange moments.

Consult manufacturers if gaskets are to be specified thinner than 3.2 mm (1/8 in) or if gasket material is specified to be something other than rubber.¹¹ For non-

metallic gaskets, installation procedures are critical. The manufacturer's installation procedures should be followed exactly.

The compression used depends upon the bolt loading before internal pressure is applied. Typically, gasket compressions for steel raised-face flanges range from 28 to 43 times the working pressure in classes 150 to 400, and 11 to 28 times in classes 600 to 2,500 with an assumed bolt stress of 414 MPa (60,000 psi). Initial compressions typically used for other gasket materials are listed in Table 3-4.

Table 3-4 Gasket Compression	
Gasket Material	Initial Compression, MPa (psi)
Soft Rubber	27.6 to 41.4 (4,000 to 6,000)
Laminated Asbestos	82.7 to 124 (12,000 to 18,000)
Composition	207 (30,000)
Metal Gaskets	207 to 414 (30,000 to 60,000)
Note: These guidelines are generally accepted practices. Designs conform to manufacturer's recommendations. Source: SAIC, 1998	

In addition to initial compression, a residual compression value, after internal pressure is applied, is required to maintain the seal. A minimum residual gasket compression of 4 to 6 times the working pressure is standard practice. See Paragraph 3-5c, following, for determination of bolting loads and torque.

¹⁰ AWWA C110, p. ix-x.

¹¹ Ibid., p. 44.

c. Bolting Materials

Carbon steel bolts, generally ASTM A 307 grade B material, should be used where cast iron flanges are installed with flat ring gaskets that extend only to the bolts. Higher strength bolts may be used where cast iron flanges are installed with full-face gaskets and where ductile iron flanges are installed (using ring or full-face gaskets).¹² For other flange materials, acceptable bolting materials are tabulated in ASME B16.5. Threading for bolts and nuts commonly conform to ASME B1.1, Unified Screw Threads.

The code requirements for bolting are contained in Sections III and VIII of the ASME Boiler and Pressure Vessel Code. To determine the bolt loads in the design of a flanged connection that uses ring-type gaskets, two analyses are made and the most severe condition is applied. The two analyses are for operating conditions and gasket seating.

Under normal operating conditions, the flanged connection (i.e., the bolts) resists the hydrostatic end force of the design pressure and maintains sufficient compression on the gasket to assure a leak-free connection. The required bolt load is calculated by¹³:

$$W_{m1} = 0.785 G^2 P + (2 b)(3.14 G m P)$$

where:

- W_{m1} = minimum bolt load for operating conditions, N (lb)
- G = gasket diameter, mm (in)
 - = mean diameter of gasket contact face when seating width, $b, \leq 6.35$ mm (0.25 in), or
 - = outside diameter of gasket contact face less 2 b when seating width, $b, > 6.35$ mm (0.25 in)
- P = design pressure, MPa (psi)
- b = effective gasket seating width, mm (in), see code (e.g., ASME Section VIII, Appendix 2, Table 2-5.2)
- m = gasket factor, see Table 3-5

The required bolt area is then:

$$A_{m1} = \frac{W_{m1}}{S_b}$$

where:

- A_{m1} = total cross-sectional area at root of thread, mm² (in²)
- W_{m1} = minimum bolt load for operating conditions, N (lb)
- S_b = allowable bolt stress at design temperature, MPa (psi), see code (e.g. ASME Section VIII, UCS-23)

Gasket seating is obtained with an initial load during joint assembly at atmosphere temperature and pressure. The required bolt load is:

$$W_{m2} = 3.14 b G y$$

where:

- W_{m2} = minimum bolt load for gasket seating, N (lbs)
- b = effective gasket seating width, mm (in), see code (e.g., ASME Section VIII, Appendix 2, Table 2-5.2)
- G = gasket diameter, mm (in)
 - = mean diameter of gasket contact face when seating width, $b, \leq 6.35$ mm (0.25 in)
 - = outside diameter of gasket contact face less 2 b when seating width, $b > 6.35$ mm (0.25 in)
- y = gasket unit seating load, MPa (psi), see Table 3-5

The required bolt area is then:

$$A_{m2} = \frac{W_{m2}}{S_a}$$

where:

- A_{m2} = total cross-sectional area at root thread, mm² (in²)
- W_{m2} = minimum bolt load for gasket seating, N (lbs)
- S_a = allowable bolt stress at ambient temperature, MPa (psi), see code (e.g. ASME Section VIII, UCS-23)

¹² AWWA C110, p. 44.

¹³ ASME Section VIII, pp. 327-333.

Table 3-5 Gasket Factors and Seating Stress		
Gasket Material	Gasket Factor, m	Minimum Design Seating Stress, y, MPa (psi)
Self-energizing types (o-rings, metallic, elastomer)	0	0 (0)
Elastomers without fabric below 75A Shore Durometer	0.50	0 (0)
75A or higher Shore Durometer	1.00	1.38 (200)
Elastomers with cotton fabric insertion	1.25	2.76 (400)
Elastomers with asbestos fabric insertion (with or without wire reinforcement)		
3-ply	2.25	15.2 (2,200)
2-ply	2.50	20.0 (2,900)
1-ply	2.75	25.5 (3,700)
Spiral-wound metal, asbestos filled		
carbon	2.50	68.9 (10,000)
stainless steel, Monel and nickel-based alloys	3.00	68.9 (10,000)
Corrugated metal, jacketed asbestos filled or asbestos inserted		
soft aluminum	2.50	20.0 (2,900)
soft copper or brass	2.75	25.5 (3,700)
iron or soft steel	3.00	31.0 (4,500)
Monel or 4% to 6% chrome	3.25	37.9 (5,500)
stainless steels and nickel-based alloys	3.50	44.8 (6,500)
Corrugated metal		
soft aluminum	2.75	25.5 (3,700)
soft copper or brass	3.00	31.0 (4,500)
iron or soft steel	3.25	37.9 (5,500)
Monel or 4% to 6% chrome	3.50	44.8 (6,500)
stainless steels and nickel-based alloys	3.75	52.4 (7,600)
Ring joint		
iron or soft steel	5.50	124 (18,000)
Monel or 4% to 6% chrome	6.00	150 (21,800)
stainless steels and nickel-based alloys	6.50	179 (26,000)
Notes: This table provides a partial list of commonly used gasket materials and contact facings with recommended design values m and y. These values have generally proven satisfactory in actual service. However, these values are recommended and not mandatory; consult gasket supplier for other values.		
Source: ASME Section VIII of the Boiler and Pressure Vessel Code, Appendix 2, Table 2-5.1, Reprinted by permission of ASME.		

The largest bolt load and bolt cross-sectional area controls the design. The bolting is selected to match the required bolt cross-sectional area by:

$$A_s = 0.7854 \left(D - \frac{0.9743}{N} \right)^2$$

where:

- A_s = bolt stressed area, mm² (in²)
- D = nominal bolt diameter, mm (in)
- N = threads per unit length, 1/mm (1/in)

The tightening torque is then calculated using the controlling bolt load¹⁴:

$$T_m = W_m K D n$$

where:

- T_m = tightening torque, N-m (in-lb)
- W_m = required bolt load, N (lb)
- K = torque friction coefficient
= 0.20 for dry
= 0.15 for lubricated
- D = nominal bolt diameter, mm (in)
- n = conversion factor, 10⁻³ m/mm for SI units (1.0 for IP units)

3-6. Pipe Identification

Pipes in exposed areas and in accessible pipe spaces shall be provided with color band and titles adjacent to all valves at not more than 12 m (40 ft) spacing on straight pipe runs, adjacent to directional changes, and on both sides where pipes pass through wall or floors. Piping identification is specified based on CEGS 09900 which provides additional details and should be a part of the contract documents. Table 3-6 is a summary of the requirements

a. Additional Materials

Piping systems that carry materials not listed in Table 3-6 are addressed in liquid process piping designs in accordance with ANSI A13.1 unless otherwise stipulated

by the using agency. ANSI A13.1 has three main classifications: materials inherently hazardous, materials of inherently low hazard, and fire-quenching materials. All materials inherently hazardous (flammable or explosive, chemically active or toxic, extreme temperatures or pressures, or radioactive) shall have yellow coloring or bands, and black legend lettering. All materials of inherently low hazard (liquid or liquid admixtures) shall have green coloring or bands, and white legend lettering. Fire-quenching materials shall be red with white legend lettering.

3-7. Piping Supports

Careful design of piping support systems of above grade piping systems is necessary to prevent failures. The design, selection and installation of supports follow the Manufacturers Standardization Society of the Valve and Fitting Industry, Inc. (MSS) standards SP-58, SP-69, and SP-89, respectively. The objective of the design of support systems for liquid process piping systems is to prevent sagging and damage to pipe and fittings. The design of the support systems includes selection of support type and proper location and spacing of supports. Support type selection and spacing can be affected by seismic zone(see Paragraph 2-5b).

a. Support Locations

The locations of piping supports are dependent upon four factors: pipe size, piping configuration, locations of valves and fittings, and the structure available for support. Individual piping materials have independent considerations for span and placement of supports.

Pipe size relates to the maximum allowable span between pipe supports. Span is a function of the weight that the supports must carry. As pipe size increases, the weight of the pipe also increases. The amount of fluid which the pipe can carry increases as well, thereby increasing the weight per unit length of pipe.

The configuration of the piping system affects the location of pipe supports. Where practical, a support should be located adjacent to directional changes of piping. Otherwise, common practice is to design the length of piping between supports equal to, or less than,

¹⁴ Schweitzer, Corrosion-Resistant Piping Systems, p. 9.

Table 3-6 Color Codes for Marking Pipe			
MATERIAL	LETTERS AND BAND	ARROW	LEGEND
Cold Water (potable)	Green	White	POTABLE WATER
Fire Protection Water	Red	White	FIRE PR. WATER
Hot Water (domestic)	Green	White	H. W.
Hot Water recirculating (domestic)	Green	White	H. W. R.
High Temp. Water Supply	Yellow	Black	H. T. W. S
High Temp. Water Return	Yellow	Black	H.T.W.R.
Boiler Feed Water	Yellow	Black	B. F.
Low Temp. Water Supply (heating)	Yellow	Black	L.T.W.S.
Low Temp. Water Return (heating)	Yellow	Black	L.T.W.R.
Condenser Water Supply	Green	White	COND. W.S.
Condenser Water Return	Green	White	COND. W.R.
Chilled Water Supply	Green	White	C.H.W.S.
Chilled Water Return	Green	White	C.H.W.R.
Treated Water	Yellow	Black	TR. WATER
Chemical Feed	Yellow	Black	CH. FEED
Compressed Air	Yellow	Black	COMP. AIR
Natural Gas	Blue	White	NAT. GAS
Freon	Blue	White	FREON
Fuel Oil	Yellow	Black	FUEL OIL
Steam	Yellow	Black	STM.
Condensate	Yellow	Black	COND.
Source: USACE, Guide Specification 09900, Painting, General, Table 1.			

75% of the maximum span length where changes in direction occur between supports. Refer to the appropriate piping material chapters for maximum span lengths.

As discussed in Chapter 10, valves require independent support, as well as meters and other miscellaneous fittings. These items contribute concentrated loads to the piping system. Independent supports are provided at each side of the concentrated load.

Location, as well as selection, of pipe supports is dependent upon the available structure to which the support may be attached. The mounting point shall be able to accommodate the load from the support. Supports are not located where they will interfere with other design considerations. Some piping materials require that they are not supported in areas that will expose the piping material to excessive ambient temperatures. Also, piping is not rigidly anchored to surfaces that transmit vibrations. In this case, pipe supports isolate the piping system from vibration that could compromise the structural integrity of the system.

b. Support Spans

Spacing is a function of the size of the pipe, the fluid conveyed by piping system, the temperature of the fluid and the ambient temperature of the surrounding area. Determination of maximum allowable spacing, or span between supports, is based on the maximum amount that the pipeline may deflect due to load. Typically, a deflection of 2.5 mm (0.1 in) is allowed, provided that the maximum pipe stress is limited to 10.3 MPa (1,500 psi) or allowable design stress divided by a safety factor of 4¹⁵, whichever is less. Some piping system manufacturers and support system manufacturers have information for their products that present recommended spans in tables or charts. These data are typically empirical and are based upon field experience. A method to calculate support spacing is as follows:

$$l = n \left(m C' \frac{Z S}{W} \right)^{0.5}$$

where:

- l = span, m (ft)
- n = conversion factor, 10⁻³ m/mm (1 ft/12 in)
- m = beam coefficient, see Table 3-7
- C' = beam coefficient = 5/48 for simple, one-span beam (varies with beam type)
- Z = section modulus, mm³ (in³)
- S = allowable design stress, MPa (psi)
- W = weight per length, N/mm (lb/in)

$$Z = \frac{\pi}{32} \frac{D_o^4 - D_i^4}{D_o}$$

where:

- Z = section modulus, mm³ (in³)
- D_o = outer pipe diameter, mm (in)
- D_i = inner pipe diameter, mm (in)

Table 3-7 Beam Coefficient (m)	
m	Beam Characteristic
76.8	simple, single span
185.2	continuous, 2-span
144.9	continuous, 3-span
153.8	continuous, 4 or more span
<p>Note: These values assume a beam with free ends and uniform loads. For piping systems with a fixed support, cantilever beam coefficients may be more appropriate. Source: Manual of Steel Construction, pp. 2-124 to 2-127.</p>	

The term W, weight per length, is the uniformly distributed total weight of the piping system and includes the weight of the pipe, the contained fluid, insulation and

¹⁵ Schweitzer, *Corrosion-Resistant Piping Systems*, p. 5.

jacket, if appropriate. Due to the many types of insulation, the weight must be calculated after the type of insulation is selected; see Chapter 11 for insulation design. The following formula can be used to determine the weight of insulation on piping:

$$W_i = \pi K \delta T_i (D_o + T_i)$$

where:

- W_i = weight of insulation per length, N/mm (lbs/in)
- δ = insulation specific weight, N/m³ (lbs/ft³)
- K = conversion factor, 10⁻⁹ m³/mm³ (5.79 x 10³ ft³/in³)
- T_i = insulation thickness, mm (in)
- D_o = outer pipe diameter, mm (in)

Proper spacing of supports is essential to the structural integrity of the piping system. An improperly spaced support system will allow excessive deflection in the line. This can cause structural failure of the piping system, typically at joints and fittings. Excessive stress can also allow for corrosion of the pipe material by inducing stress on the pipe and, thereby, weakening its resistance to corrosive fluids.

The amount of sag, or deflection in a span, is calculated from the following equation:

$$y = \frac{W (l/n)^4}{m E I}$$

where:

- y = deflection, mm (in)
- W = weight per length, N/mm (lb/in)
- l = span, m (ft)
- n = conversion factor, 10⁻³ m/mm (1 ft/12 in)
- m = beam coefficient, see Table 3-7.
- E = modulus of elasticity of pipe material, MPa (psi)
- I = moment of inertia, mm⁴ (in⁴)

$$I = \frac{\pi}{64} (D_o^4 - D_i^4)$$

where:

- I = moment of inertia, mm⁴ (in⁴)
- D_o = outer pipe diameter, mm (in)
- D_i = inner pipe diameter, mm (in)

Improper spacing of supports can allow fluids to collect in the sag of the pipe. Supports should be spaced and mounted so that piping will drain properly. The elevation of the down-slope pipe support should be lower than the elevation of the lowest point of the sag in the pipe. This is determined by calculating the amount of sag and geometrically determining the difference in height required.

$$h = \frac{(l/n)^2 y}{0.25 (l/n)^2 - y^2}$$

where:

- h = difference in elevation of span ends, mm, (in)
- l = span, m (ft)
- n = conversion factor, 10⁻³ m/mm (1 ft/12 in)
- y = deflection, mm (in)

c. Support Types

The type of support selected is equally important to the design of the piping system. The stresses and movements transmitted to the pipe factor in this selection. Pipe supports should not damage the pipe material or impart other stresses on the pipe system. The basic type of support is dictated by the expected movement at each support location.

The initial support design must address the load impact on each support. Typically, a moment-stress calculation is used for 2-dimensional piping, and a simple beam analysis is used for a straight pipe-run.

If a pipe needs to have freedom of axial movement due to thermal expansion and contraction or other axial movement, a roller type support is selected. If minor axial and transverse (and minimal vertical) movements are expected, a hanger allowing the pipe to 'swing' is selected. If vertical movement is required, supports with springs or hydraulic dampers are required. Other structural requirements and conditions that have the potential to affect piping systems and piping support systems are analyzed. Pipes that connect to heavy tanks

or pass under footings are protected from differential settlement by flexible couplings. Similarly, piping attached to vibrating or rotating equipment are also attached with flexible couplings.

d. Selection of Support Types

The selection of support types is dependent upon four criteria: the temperature rating of the system, the mechanism by which the pipe attaches to the support, protective saddles that may be included with the support, and the attachment of the support to the building or other structures. Support types are most commonly classified in accordance with MSS SP-58. Figure 3-2 displays some of the support types applicable to liquid process piping systems. The selection of the appropriate support type is made according to MSS SP-69. Table 3-8 provides guidance for process system temperatures.

Some piping systems utilize protective saddles between the pipe and the support member. This is done to minimize the stress on the pipe from point loads. In addition, pipe insulation requires protection from supports. Saddles support piping without damaging insulation.

The method by which the supports attach to buildings or other structures is addressed by the design. Typical pipe supports are in the form of hangers, supporting the pipe from above. These hangers may be attached to a ceiling, beam, or other structural member. Pipelines may be supported from below as well, with pipe stanchions or pipe racks. Pipe supports may be rigidly attached to a structure, or allow for a pivoting axial motion, depending on the requirements of the system.

<p align="center">Table 3-8 Support Type Selection for Horizontal Attachments: Temperature Criteria</p>		
<p>Process Temperature, °C (°F)</p>	<p>Typical MSS SP-58 Types</p>	<p>Application</p>
<p>A-1. Hot Systems 49 to 232°C (120 to 450°F)</p>	<p>2, 3, 24, 1, 5, 7, 9, 10, 35 through 38, 59, 41, 43 through 46, 39, 40</p>	<p>clamps hangers sliding rollers insulation protection</p>
<p>B. Ambient Systems 16 to 48°C (60 to 119°F)</p>	<p>3, 4, 24, 26, 1, 5, 7, 9, 10, 35 through 38, 59, 41, 43 through 46, 39, 40</p>	<p>clamps hangers sliding rollers insulation protection</p>
<p>C-1. Cold Systems 1 to 15°C (33 to 59°F)</p>	<p>3, 4, 26, 1, 5, 7, 9, 10, 36 through 38, 59, 41, 43 through 46, 40</p>	<p>clamps hangers sliding rollers insulation protection</p>
<p>Source: MSS SP-69, pp. 1, 3-4.</p>		

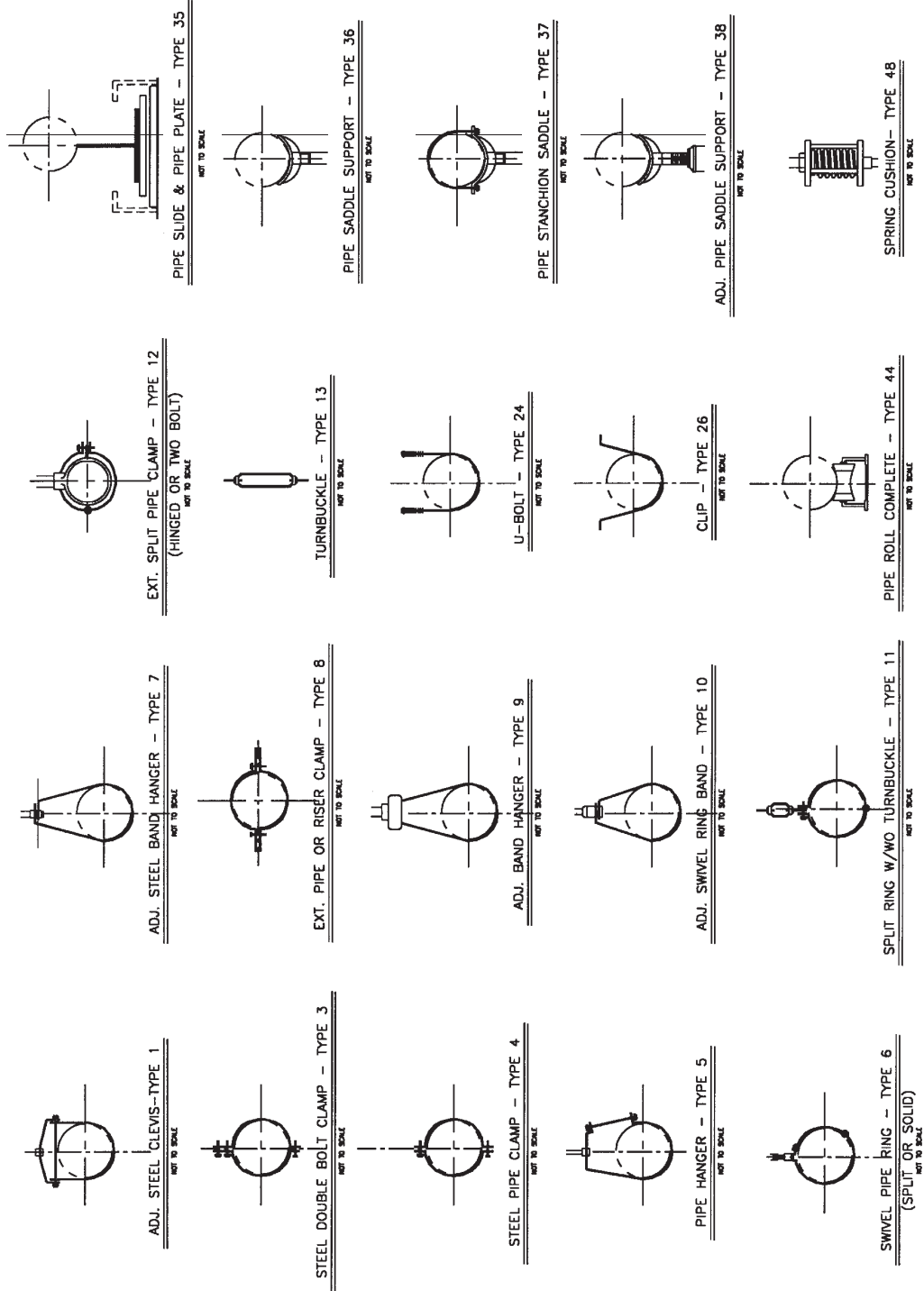

Figure 3-2. Pipe Supports for Ambient Applications
 (Source: MSS SP-69, Pipe Hangers and Supports - Selection and Application, pp. 5-6)

Some piping systems require adjustable pipe supports. One reason for this requirement is the cold spring action. Cold spring is the action whereby a gap is left in the final joint of a piping run to allow for thermal expansion of the pipeline. This action results in the offset of all points along the piping system, including the attachments to pipe supports, and requires that supports be adjustable to accommodate this offset. From a maintenance consideration, cold springing should be avoided if possible through proper thermal expansion and stress analyses.

Vertical adjustment is also usually necessary for pipe supports. Settlement, particularly in new construction, may result in an improper deflection of the elevation of a pipe support. To maintain the proper slope in the pipeline, thereby avoiding excessive sag between supports and accumulation of the product being carried by the pipe, the possibility of vertical adjustment is accommodated in the design of pipe supports.

e. Coatings

Installation of piping systems in corrosive environments may warrant the specification of a protective coating on pipe supports. The coating may be metallic or non-metallic; MSS SP-58 is used to specify coatings. Support manufacturers can provide specific recommendations for coatings in specific environments, particularly for nonmetallic coatings. In addition, compatibility between the support materials and piping system materials is reviewed to avoid galvanic action. Electrical isolation pads or different support materials are sometimes required.

3-8. Testing and Flushing

This section addresses the requirements for pressure and leak testing of piping systems. In addition to these types of tests, welding procedures, welders and qualifications of welding operators must conform with the welding and nondestructive testing procedures for pressure piping specified in CEGS 05093, Welding Pressure Piping.

a. Test Procedure

A written test procedure is specified and utilized to perform a leak test. The procedure should prescribe standards for reporting results and implementing corrective actions, if necessary. Review items for

preparing the test plans and procedures include:

- (1) Determination of the test fluid.
- (2) Comparison of the probable test fluid temperature relative to the brittle fracture toughness of the piping materials (heating the test fluid may be a solution).
- (3) Depending upon the test fluid, placement of temporary supports where permanent supports were not designed to take the additional weight of the test fluid.
- (4) Depending upon the test fluid, location of a relief valve to prevent excessive over-pressure from test fluid thermal expansion. No part of the system will exceed 90% of its yield strength.
- (5) Isolation of restraints on expansion joints.
- (6) Isolation of vessels, pumps and other equipment which may be over stressed at test pressure.
- (7) Location of the test pump and the need for additional pressure gauges.
- (8) Accessibility to joints for inspection (some codes require that the weld joints be left exposed until after the test). All joints in the pipe system must be exposed for inspection.
- (9) Prior to beginning a leak test, the pipe line should be inspected for defects and errors and omissions.

Testing of piping systems is limited by pressure. The pressure used to test a system shall not produce stresses at the test temperature that exceed the yield strength of the pipe material. In addition, if thermal expansion of the test fluid in the system could occur during testing, precautions are taken to avoid extensive stress.

Testing of piping systems is also limited by temperature. The ductile-brittle transition temperature should be noted and temperatures outside the design range avoided. Heat treatment of piping systems is performed prior to leak testing. The piping system is returned to its ambient temperature prior to leak testing.

In general, piping systems should be re-tested after repairs or additions are made to the system. If a leak is detected during testing and then repaired, the system should be re-tested. If a system passes a leak test, and a component is added to the system, the system should be re-tested to ensure that no leaks are associated with the new component.

The documented test records required for each leak test are specified. The records are required to be standardized, completed by qualified, trained test personnel and retained for a period of at least 5 years. Test records include:

- date of the test;
- personnel performing the test and test location;
- identification of the piping system tested;
- test method, fluid/gas, pressure, and temperature; and
- certified results.

Flushing of a piping system prior to leak testing should be performed if there is evidence or suspicion of contaminants, such as dirt or grit, in the pipeline. These contaminants could damage valves, meters, nozzles, jets, ports, or other fittings. The flushing medium shall not react adversely or otherwise contaminate the pipeline, testing fluid, or service fluid. Flushing should be of sufficient time to thoroughly clean contaminants from every part of the pipeline.

b. Preparation

Requirements for preparation of a leak test are also specified. All joints in the piping system are exposed for the leak test in order to allow the inspector to observe the joints during the test to detect leaks. Specified leak test requirements provide for temporary supports. Temporary supports may be necessary if the test fluid weighs more than the design fluid.

c. Hydrostatic Leak Test

The fluid used for a typical hydrostatic leak test is water. If water is not used, the fluid shall be non-toxic and be non-flammable. The test pressure is greater than or equal to 1.5 times the design pressure.

$$P_T \geq 1.5 P$$

where:

- P_T = test pressure, MPa (psi)
- P = design pressure, MPa (psi)

For cases in which the test temperature is less than the design temperature, the minimum test pressure is¹⁶:

$$P_T = \frac{1.5 P S_T}{S}$$

and

$$\frac{S_T}{S} \leq 6.5$$

where:

- P_T = test pressure, MPa (psi)
- P = design pressure, MPa (psi)
- S_T = stress at test temperature, MPa (psi)
- S = stress at design temperature, MPa (psi)

For a typical liquid process piping system with temperatures approximately ambient and low pressure, the S_T/S ratio equals 1.0. If the test pressure would produce an S_T in excess of the material yield strength, then the test pressure may be reduced to limit S_T below the yield strength.

The time period required by ASME B31.3 for a hydrostatic leak test is at least ten (10) minutes, but normally one (1) hour is used.

d. Pneumatic Leak Test

Pneumatic leak tests are not recommended for liquid process piping systems and are only used when the liquid residue left from a hydrostatic test has a hazard potential. The test fluid for a pneumatic leak test is a gas. The gas shall be non-flammable and non-toxic. The hazard of released energy stored in a compressed gas shall be considered when specifying a pneumatic leak test. Safety must be considered when recommending a gas for use in this test.

The test temperature is a crucial consideration for the pneumatic leak test. Test temperature shall be considered

¹⁶ ASME B31.3, p. 83.

when selecting the pipe material. Brittle failure is a consideration in extremely low temperatures for some materials. The energy stored in a compressed gas, combined with the possibility of brittle failure, is an essential safety consideration of the pneumatic leak test.

A pressure relief device shall be specified when recommending the pneumatic leak test. The pressure relief device allows for the release of pressure in the piping system that exceeds a set maximum pressure. The set pressure for the pressure relief device shall be 110% of the test pressure, or 345 kPa (50 psig) above test pressure, whichever is lower.

The test pressure for a pneumatic leak test is 110% of the design pressure. The pressure shall gradually increase to 50% of the test pressure or 170 kPa (25 psig), whichever is lower, at which time the piping system is checked. Any leaks found are then fixed before retesting. The test shall then proceed up to the test pressure before examining for leakage.

e. Initial Service Leak Test

An initial service leak test is permitted by ASME B31.3 with the concurrence of the using agency. This test is a preliminary check for leakage at joints and connections. If this test is performed, and all observed leaks are repaired, it is permissible to omit joint and connection examination during the hydrostatic (or pneumatic) leak tests. The initial service leak test is limited to piping systems subject to Category D fluid service only.

A Category D fluid is defined as non-flammable, non-toxic, and not damaging to human tissues. For this system the operating pressure is less than 1.035 MPa (150 psi), and the operating temperature range is between -29°C (-20°F) to 186°C (366°F)¹⁷.

Typically, the service fluid is used for the initial service leak test. This is possible for a Category D fluid. During the test, the pressure in the piping system should be gradually increased to operating pressure. The piping system is then inspected for leaks.

f. Sensitive Leak Test

A sensitive leak test is required for all Category M fluids (optional for Category D fluids) using the Gas and Bubble Test Method of the ASME Boiler and Pressure Vessel Code, Section V, Article 10, or equivalent. The test pressure for the sensitive leak test is 25% of the design pressure or 105 kPa (15 psig), whichever is lower.

Category M fluid service is one in which the potential for personnel exposure is judged to be possible, and in which a single exposure to a small quantity of the fluid (caused by leakage) can produce serious and irreversible personnel health damage upon either contact or breathing.¹⁸

g. Non-Metallic Piping Systems

Testing requirements, methods, and recommendations for plastic, rubber and elastomer, and thermoset piping systems are the same as those for metallic piping systems, with the following exceptions. The hydrostatic leak test method is recommended and a pneumatic leak test is only performed with the permission of the using agency. The test pressure shall not be less than 1.5 times the system design pressure. However, the test pressure is less than the lowest rated pressure of any component in the system.

$$P_T \geq 1.5 P$$

and

$$P_T < P_{\min}$$

where:

P_T = test pressure, MPa (psi)

P = system design pressure, MPa (psi)

P_{\min} = lowest component rating, MPa (psi)

h. Double Containment and Lined Piping Systems

Testing requirements, methods, and recommendations for double containment and lined piping systems are identical to those pertaining to the outer (secondary) pipe material.

¹⁷ ASME B31.3, p. 5.

¹⁸ Ibid., p. 5.

Chapter 4 Metallic Piping Systems

4-1. General

The metallic materials that are commonly used in liquid process piping systems can be categorized as ferrous (ductile iron, carbon steel, stainless steel and alloys with iron as the principal component) and non-ferrous alloys of nickel, aluminum, copper and lead. Metallic piping systems other than those addressed in this chapter are available (e.g. zirconium, 416 SS). Such materials may be used if cost and technical criteria are met. Applicable design principles from this manual are applied to use these materials.

4-2. Corrosion

When metallic components are used, corrosion of some type(s) will occur. USACE policy requires that all underground ferrous piping be cathodically protected. Chapter 12, TM 5-811-7 and MIL-HDBK-1004/10 contain guidance pertaining to cathodic protection of underground pipelines. Conditions which promote corrosion are:

- contact between dissimilar metals which may become immersed in a conductive medium;
- exposure of piping to corrosive soils or water;
- high temperatures;
- low-velocity, stagnant-type flow conditions;
- abrasive effects that may cause the surfaces of metals to be eroded;
- application of tensile stresses within a corrosive environment;
- highly acidic solutions combined with holes near metal-to-metal surfaces or near sealing surfaces; and
- any metals close to sources of atomic hydrogen.

a. Theory of Corrosion

Corrosion occurs by an electrochemical process. The phenomenon is similar to that which takes place when a carbon-zinc "dry" cell generates a direct current. Basically, an anode (negative electrode), a cathode (positive electrode), electrolyte (corrosive environment), and a metallic circuit connecting the anode and the cathode are required for corrosion to occur. Dissolution

of metal occurs at the anode where the corrosion current enters the electrolyte and flows to the cathode. The general reaction which occurs at the anode is the dissolution of metal as ions:

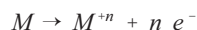

where:

M = metal involved

n = valence of the corroding metal species

e⁻ = represents the loss of electrons from the anode.

Examination of this basic reaction reveals that a loss of electrons, or oxidation, occurs at the anode. Electrons lost at the anode flow through the metallic circuit to the cathode and permit a cathodic reaction (or reactions) to occur.

Practically all corrosion problems and failures encountered in service can be associated with one or more of the following basic forms of corrosion. These are: general corrosion, galvanic corrosion, concentration cell (crevice) corrosion, pitting attack, intergranular corrosion, stress-corrosion cracking (environmentally-induced-delayed failure), dealloying (dezincification and graphitic corrosion), and erosion corrosion.

Corrosion control and avoidance is a highly specialized field. All pre-design surveys, Cathodic Protection (CP) designs, and acceptance surveys must be performed by a "corrosion expert." A "corrosion expert" is a person who, by reason of thorough knowledge of the physical sciences and the principles of engineering and mathematics acquired by a professional education and related practical experience, is qualified to engage in the practice of corrosion control of buried or submerged metallic piping and tank systems. Such a person must be accredited or certified by the National Association of Corrosion Engineers (NACE) as a NACE Accredited Corrosion Specialist or a NACE certified CP Specialist or be a registered professional engineer who has certification or licensing that includes education and experience in corrosion control of buried or submerged metallic piping and tank systems. USACE Construction Engineering Research Laboratories (CECER) provides corrosion expertise on request.

For information on metallic piping system material compatibility with various chemicals, see appendix B. Material compatibility considers the type and concentration of chemical in the liquid, liquid temperature and total stress of the piping system. The selection of construction materials is made by an engineer experienced in corrosion. See Appendix A, paragraph A-4 - Other Sources of Information, for additional sources of corrosion data.

b. General Corrosion

General corrosion is sometimes referred to as uniform attack. When this form of corrosion occurs, anodic dissolution is uniformly distributed over the entire metallic surface. The corrosion rate is nearly constant at all locations. Microscopic anodes and cathodes, which are continuously changing their electrochemical behavior from anode to cathode and cathode to anode, are believed to provide the corrosion cells for uniform attack.

Readily obtained from weight-loss and electrochemical tests, the general corrosion rates for many metals and alloys in a wide variety of environments are known. When a metal or alloy is exposed to an environment where the corrosion rate is known, equipment-life expectancy can be estimated (providing general corrosion is the only form of corrosion which will occur). It is common practice to select materials having general corrosion rates which are acceptable for the application involved.

Time-to-failure should not be the only corrosion criteria used for materials selection. Quite often, even trace amounts of metal which are introduced into the environment by very low corrosion rates are, or should be, unacceptable. For example, relatively non-corrosive domestic waters can dissolve sufficient amounts of certain metals, such as lead and copper, from the piping to create a health hazard. Corrosion-produced trace elements which are considered toxic and frequently found in the domestic waters of buildings include cadmium and antimony (from solder) and lead (an impurity in hot-dip, galvanized coatings).

One of the environments where general corrosion can occur is soil. Steel is especially susceptible to general corrosion when exposed to soils having resistivities less than about 10,000 ohm-cm. Even galvanized-steel can

be expected to fail in these aggressive environments. As the resistivity of the soil decreases, the magnitude of the corrosion damage increases.

c. Galvanic Corrosion

Galvanic corrosion can occur when two electrochemically-dissimilar metals or alloys (see Table 4-1) are metallically connected and exposed to a corrosive environment. The less noble material (anode) suffers accelerated attack and the more noble material (cathode) is protected by the galvanic current.

Table 4-1 Galvanic Series (Partial Listing)	
Wasting End (anodic or least noble)	
Magnesium alloys Zinc Galvanized steel Aluminum Aluminum alloys Carbon steel Cast iron Stainless steel (active state) Lead Nickel (active state) Brass Copper Bronze Nickel alloys Nickel (passive state) Stainless steel (passive state) Titanium Graphite Platinum	
Protected End (cathodic or most noble)	
Sources: Schweitzer, <u>Corrosion-Resistant Piping Systems</u> , p. 264 (courtesy of Marcel Dekker, Inc.). SAIC, 1998.	

One common galvanic corrosion problem clearly illustrates the "area and distance effects". For example, consider a building where a copper water service line and

a coated carbon steel natural gas service line are laid in the same ditch. Assuming soil in the area has low resistivity, it is easily recognized that a cathode (copper tube), an anode (steel pipe), and an electrolyte (soil) exist. In order to have a galvanic cell, only a metallic path for electron flow is needed; this is provided when the two dissimilar materials are metallicity connected through the hot-water heater. Because the cathodic area is large (bare copper tube) and the anodic area is small (steel exposed at locations where "holidays", or defects, exist in the coating), corrosion produced leaks in the natural gas line can occur in relatively short times. (Generally, natural gas leaks occur first in soil near the foundations of buildings where fertilizing and watering have lowered the resistivity of the native soil.) The fact that the two service lines were laid only inches apart and in the same ditch is also a factor in this corrosion problem. Had the lines been located in separate ditches, the distance between them may have been sufficient to prevent the flow of galvanic current.

Severe galvanic corrosion is a problem in many potable-water systems. Providing the water is sufficiently aggressive, connecting steel or galvanized steel (the zinc coating is generally destroyed by threading) to copper or copper-base alloys will cause galvanic attack of the steel. Similarly, connecting aluminum and its alloys to copper-base materials exposed to corrosive potable waters generally accelerates attack of the aluminum. However, there are many waters where dissimilar metals and alloys can be directly connected without accelerated attack of the less noble material. In general, waters of high pH and low carbon dioxide, or those capable of producing a thin continuous layer of calcareous scale on the metal surface, do not promote galvanic attack.

Galvanic corrosion is also an important cause of rapid deterioration to underground aluminum-alloy structures. For example, in aircraft refueling areas, it is common practice to use aluminum-alloy pipe between the filter-meter pit and the hydrant outlets. Steel pipe is usually used between the filter meter pit and the fuel storage area. For safety, convenience, and aesthetic reasons, all of the pipe is underground. When the two dissimilar pipe materials (see Table 4-1) are metallicity connected (for example, flanged at a filter meter pit) and exposed to a highly conductive, chloride containing soil, galvanic corrosion can be expected to occur. In these environments, galvanic corrosion of the aluminum alloy

is generally characterized in a appearance by severe pitting attack. Cases are known where galvanic corrosion has perforated 7.6 mm (0.3 in) thick, aluminum-alloy pipe in two (2) years.

A number of methods and practices are available which will either prevent or minimize galvanic corrosion. These include: the use of materials which are electrochemically similar (that is, close together in the galvanic series); avoiding unfavorable (large) cathode-to-anode area ratios; breaking the metallic circuit by the proper use of insulators (for example, isolating flanges and insulating unions); the use of inhibitors (preferably cathodic inhibitors, or a sufficient amount of anodic inhibitor to insure that the anodic reaction will be completely stifled); keeping the dissimilar metals or alloys physically distant from each other; avoiding the use of threaded joints between dissimilar metals; cathodic protection; applying protective coatings to both dissimilar metals; and possibly increasing the resistivity of the environment.

d. Concentration Cell Corrosion

Electrochemical attack of a metal or alloy because of differences in the environment is called concentration cell corrosion. This form of corrosion is sometimes referred to as "crevice corrosion", "gasket corrosion", and "deposit corrosion" because it commonly occurs in localized areas where small volumes of stagnant solution exist. Normal mechanical construction can create crevices at sharp corners, spot welds, lap joints, fasteners, flanged fittings, couplings, threaded joints, and tube-sheet supports. Deposits which promote concentration cell corrosion can come from a number of sources; other sites for crevice attack can be established when electrolyte-absorbing materials are used for gaskets and the sealing of threaded joints.

There are at least five types of concentration cells. Of these, the "oxygen" and "metal ion" cell are most commonly considered in the technical literature. The "hydrogen ion", "neutral salt", and "inhibitor" cells must be considered in any discussion of concentration cell corrosion.

It is known that areas on a surface in contact with electrolyte having a high oxygen content will generally be cathodic relative to those areas where less oxygen is present. Oxygen can function as a cathodic depolarizer;

in neutral and alkaline environments, regions of high oxygen would be preferred cathodic sites where the reduction of oxygen can occur. This is the commonly referred to as an "oxygen concentration cell," see Figure 4-1.

A mechanism is proposed wherein the dissolution of metal (anodic process) and reduction of oxygen (cathodic process) initially occur uniformly over the entire surface, including the interior of the crevice. In time, the oxygen within the crevice is consumed and the localized (oxygen reduction) cathodic process stops in this area. The overall rate of oxygen reduction, however, remains essentially unaltered because the area within the crevice is quite small compared to the area outside of the crevice. The rate of corrosion within and outside the crevice remains equal.

Concentration cell corrosion can occur at threaded joints of pipe used to convey aggressive, liquids. When the joints are improperly sealed, rapid crevice attack occurs in the threaded area where stagnant, low-oxygen-content fluids exist. Since the wall thickness of the pipe is reduced by threading, failures due to concentration cell corrosion can be a frequent and common occurrence at threaded joints. Threaded joints sealed with liquid-absorbing materials (for example, string or hemp) can fail in times as short as nine months. Similarly, transport deposits of solids can be a major cause of concentration cell corrosion.

Some of the methods to reduce concentration cell corrosion damage include: using butt welds instead of riveted, spot-welded, and bolted joints; caulking, welding and soldering existing lap joints; avoiding the use of fluid absorbing materials for gaskets and threaded-joint sealants; providing a more uniform environment, for example, placing homogeneous sand around underground steel structures; removing suspended solids from solution; periodic cleaning to remove deposits from the surface; improving the design, for example, providing adequate slope on the inside bottoms of underground storage tanks so accumulated liquid will flow to the sump; cathodic protection; and protective coatings, especially on the interior surfaces of storage tanks and carbon steel piping.

e. Pitting Corrosion

Pitting corrosion is a randomly occurring, highly localized form of attack on a metal surface. In general, it is characterized by the observation that the depth of penetration is much greater than the diameter of the area affected. Pitting is similar to concentration cell-corrosion in many respects. The two should be distinguished, however, because crevices, deposits, or threaded joints are not requisites for pit initiation. Further, concentration cell corrosion can occur in environments where the metal or alloy is immune to pitting attack.

Pitting attack appears to occur in two distinct stages. First, there is an incubation period during which the pits are initiated; second, there is a propagation period during which the pits develop and penetrate into the metal. It is generally agreed that a sufficient concentration of an aggressive anion (generally chloride, but also bromide, iodide, and perchlorate) and an oxidizing agent (dissolved oxygen, Fe^{+++} , H_2O_2 , Cu^{++} , and certain others) must be present in the electrolyte. A stagnant volume of liquid must exist in the pit or pitting will not occur. In addition, for a given metal/electrolyte system, the redox potential must be more noble than a certain critical value. It is also agreed that the corrosion processes within the pit produce conditions of low pH and high chloride ion content; these keep the localized anodic areas electrochemically active.

Many grades of stainless steel are particularly susceptible to pitting corrosion when exposed to saline environments. Alloying elements in a stainless steel, however, greatly affect its resistance to pitting attack; the tendency to pit decreases as the content in nickel, chromium and molybdenum increases. In sea water, austenitic stainless steels containing 18% chromium and a 2-3% molybdenum addition (e.g., Type 316 stainless steel) exhibit much better pitting-corrosion resistance than similar alloys which contain no molybdenum (e.g., Type 302 stainless steel). For certain grades of ferritic stainless steel, relatively low chloride content waters can cause severe pitting corrosion. For example, Type 430, ferritic grade, stainless steel (16% Cr) tubes failed by pitting corrosion and pinhole leaks when they were used to convey cooling water containing only a small amount of chlorides.

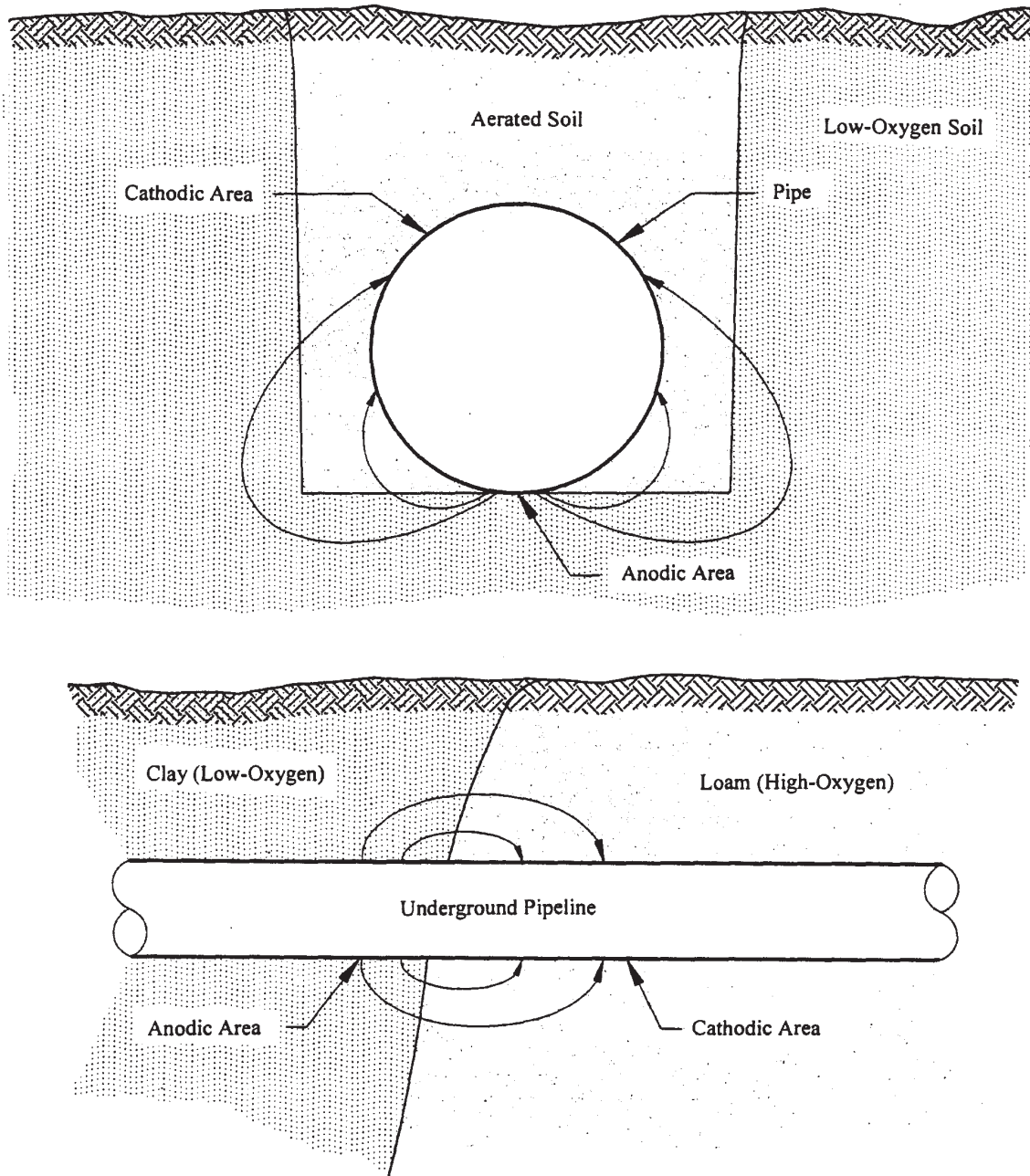

Figure 4-1. Concentration-Cell Corrosion of Underground Pipeline
(Source: USACE CECER, 1998.)

In many cases, methods which minimize concentration cell corrosion can be used to successfully mitigate pitting attack. Widely-used practices and procedures for reducing damage by pitting corrosion include: keeping the fluid uniformly aerated; keeping the fluid at a low and uniform temperature; improving the homogeneity of the metal's surface by polishing, heat treating, or passivation; using inhibitors; implementing cathodic protection; reducing the concentration of aggressive ions in the electrolyte; selecting materials which have good pitting corrosion resistance; and using anodic protection by controlling the metal or alloy's potential in the passive range at a value more negative than the critical potential for pitting.

f. Intergranular Corrosion

Intergranular corrosion is the localized attack which occurs at or in narrow zones immediately adjacent to the grain boundaries of an alloy. Severe intergranular attack usually occurs without appreciable corrosion of the grains; eventually, the alloy disintegrates or loses a significant amount of its load-bearing capability. Although a number of alloy systems are susceptible to intergranular attack, most of the problems encountered in service involve austenitic stainless steels and the 2xxx and 7xxx series aluminum alloys. Welding, stress-relief annealing, improper heat treating, or overheating in service generally establish the microscopic, compositional inhomogeneities which make a material susceptible to intergranular corrosion.

Several grades of austenitic stainless steels (for example, Type 304, which contains about 0.08% carbon) are susceptible to intergranular corrosion after they have been heated into the temperature range of about 425°C to 790°C (800°F to 1450°F). Provided the time in this temperature range is sufficiently long, but not extended, the stainless steel becomes sensitized. Intergranular corrosion will occur if the alloy is subsequently exposed to certain environments.

Some of the environments which reportedly cause intergranular corrosion in sensitized, austenitic stainless steels are listed in Table 4-2. Examination of this table reveals that intergranular corrosion can occur in many environments where austenitic stainless steels normally exhibit excellent corrosion resistance.

Table 4-2 Environments Which Cause Intergranular Corrosion in Sensitized Austenitic Stainless Steels	
Acetic Acid	Phosphoric Acid
Ammonium Nitrate	Phthalic Acid
Beet Juice	Salt Spray
Chromic Acid	Sea Water
Copper Sulfate	Sodium Bisulfate
Crude Oil	Sulfite Cooking Liquor
Fatty Acids	Sulfite Digestor Acid
Lactic Acid	Sulfamic Acid
Maleic Acid	Sulfur Dioxide (wet)
Nitric Acid	Sulfuric Acid
Oxalic Acid	Sulfurous Acid
Source: USACE CECER, 1998.	

The use of extra-low carbon grades of stainless steel, for example, Type 304L, essentially eliminates the intergranular corrosion problem. These alloys are immune to sensitization because of their low carbon content. It is well known that sensitization can occur only if the carbon content of the alloy exceeds about 0.02 to 0.03%. The control of carbon to a maximum of 0.03%, by blowing oxygen through the melt and using low-carbon ferrochrome, has permitted steel manufacturers to produce alloys which can be welded, stress-relief annealed, and used in corrosive environments without major concern for intergranular attack.

g. Stress-Corrosion Cracking

Stress-corrosion cracking (environmentally-induced-delayed failure) describes the deleterious phenomena which can occur when many alloys are subjected to static, surface tensile stresses and exposed to certain corrosive environments. Cracks are initiated and propagated by the combined effect of a surface tensile stress and the environment. When stress-corrosion cracking occurs, the tensile stress involved is often much less than the yield strength of the material; the environment is generally one in which the material exhibits good resistance to general corrosion. For example, various steels have good general

corrosion resistance to anhydrous liquid ammonia. Steel tanks are widely and successfully used for the storage and transport of this liquified gas. Stress-corrosion cracking failures have occurred in some large-diameter liquid ammonia tanks, however, probably because the high residual tensile stresses introduced during fabrication were not removed by stress-relief annealing. Several of the alloy/susceptible environment combinations where stress-corrosion cracking can occur are given in Table 4-3.

h. Dealloying

Dealloying, sometimes referred to as parting or selective leaching, is a corrosion process wherein one element is preferentially removed from an alloy. The process is unique in that corrosion occurs without appreciable change in the size or shape of the component being attacked. The affected areas become brittle, weak, and porous but the overall dimensions of the component do not change appreciably.

Table 4-3 Alloy/Susceptible Environment Combinations for Stress-Corrosion Cracking (Partial Listing)		
Alloy System	Environment	Type of Cracking
Mild Steel	OH ⁻ NO ₃ ⁻	Intergranular Intergranular
Alpha Brass (70 Cu- 30 Zn)	NH ₄ ⁺	Transgranular at high pH; intergranular in neutral solutions
Austenitic Stainless Steel	Cl ⁻	Transgranular
2XXX - Series Al Alloys	Cl ⁻	Adjacent to grain boundaries
7XXX - Series Al Alloys	Cl ⁻	Intergranular
Cu-P Alloys	NH ₄ ⁺	Intergranular
Titanium Alloys*	Cl ⁻	Transgranular or intergranular
Mg-Al Alloys	Cl ⁻	Intergranular; sometimes transgranular
Beta Brass	Cl ⁻ NH ₄ ⁺	Transgranular Intergranular
Martensitic Low-Alloy	Cl ⁻	Along prior-austenite grain boundaries
18 Ni Maraging Steel	Cl ⁻	Along prior-austenite grain boundaries
Note: *Includes Ti-8Al-1Mo-1V, Ti-6Al-4V and Ti-5Al-2.5Sn alloys. Source: USACE CECER, 1998.		

The two most important examples of dealloying are the preferential removal of zinc from copper-zinc alloys (dezincification) and the preferential removal of iron from gray-cast iron (graphitic corrosion). Other cases of dealloying include the preferential removal of aluminum, nickel, and tin from copper-base alloys and cobalt from a Co-W-Cr alloy.

Dezincification commonly occurs when yellow brass (67Cu-33Zn) is exposed to waters having a high chloride content, low temporary hardness, and pH above approximately 8. Other alloys which are susceptible to dezincification in many waters include Muntz metal (60Cu-40Zn) and non-inhibited aluminum brass (76Cu-22Zn-2Al). Generally, higher zinc content brasses are more susceptible to dezincification than alloys containing smaller amounts of the solute element.

Dezincification problems are generally solved by changing alloys. This includes the use of low-zinc-content alloys such as red brass (85Cu-15Zn) and specially-alloyed materials such as arsenical Admiralty Metal (70Cu-29Zn-1Sn-0.05As) and arsenical aluminum brass (76Cu-22Zn-2Al-0.05As). For severe applications, it may be necessary to use cupro-nickel alloys, for example, 90Cu-10Ni, which contain a small amount of iron. In some process streams, dezincification can be eliminated by changing the fluid chemistry, but this should be done with caution and not without expert advice.

i. Erosion Corrosion

Most metals and alloys depend upon a protective surface-film for corrosion resistance. When the protective film or corrosion products have poor adherence, an acceleration or increase in the rate of localized corrosion can occur because of relative movement between the liquid and the metal. Generally, movement of the liquid is quite rapid and mechanical wear effects or abrasion (due to suspended solids and entrained gases in the environment) can be involved. Repetitive formation (a corrosion process) and destruction (a mechanical erosion process) of the surface films is referred to as erosion corrosion. The term includes impingement attack, a special form of erosion corrosion is cavitation.

Many metallic materials are susceptible to erosion corrosion at sufficiently high flow rates or excessive turbulence. Some of the equipment and components where erosion-corrosion damage frequently occurs include: piping systems (particularly at elbows, tees, and bends), pump impellers, valves, propellers, orifices of measuring devices, nozzles, heat-exchanger tubes, and turbine blades. Erosion corrosion is characterized in appearance by the presence of waves, valleys, deep grooves, and gullies on the metal surface. An absence of residual corrosion products and a clean metal appearance in the area of attack also suggest that the destructive process is erosion corrosion. For copper, the effected area is usually bright and shiny, resembling that of a new penny.

Some of the other material/environmental combinations where erosion corrosion can occur include: red brass (85Cu-15Zn) in potable hot waters; hard lead (92Pb-8Sb) in heated, dilute sulfuric acid solutions; carbon steel in heated, acidified distilled waters; austenitic stainless steels in heated sulfuric acid-ferrous sulfate slurries; and cupro-nickel alloys in heated sea water. It is important to appreciate that none of these environments would appreciably corrode the respective materials under static or low-flow conditions. For example, hard lead corrodes at a negligible rate in stagnant 10% sulfuric acid at 90°C (194°F). When the same sulfuric acid solution is circulated at 11.8 m/s (39 ft/s), the erosion-corrosion penetration rate of hard lead is about 1000 microns/y (40 mils/y).

A number of techniques are available for minimizing erosion corrosion. Velocities in a system must be considered before materials are selected and used. Materials which are susceptible to erosion corrosion should not be used when the environment is going to be circulated at high velocities. For this reason, copper tubing is not recommended for conveying aggressive, potable hot waters at temperatures above 60°C (140°F); 90-10 cupro-nickel should be used when high-temperature, potable waters must be circulated at high flow rates. Similarly, use of Monel can generally eliminate the "wire drawing" which occurs in brass valve seats.

Cavitation corrosion is a special form of erosion corrosion. The process is basically the result of gas bubbles forming at low pressure and collapsing under high pressure at or near the liquid-metal interface. Bubble collapse, which produces very high localized pressures (shock waves), destroys the metal's protective film. Repetitive formation and destruction of the film on a localized basis results in severe damage. Cavitation corrosion damaged surfaces are characterized by their deeply pitted and "spongy" appearance.

j. Microbially Induced Corrosion

Microbiological activity can induce corrosion as a result of byproducts such as carbon dioxide, hydrogen sulfide, ammonia and acids. In some instances microorganisms may also consume metal. Biological activity can be reduced through the use of biocides and/or occasional pH variations.

4-3. Design Pressure

In addition to the requirements of Paragraph 3-2, a key consideration when specifying metal pipe and components is compliance with established pressure and temperature rating of applicable codes and standards.

a. Maximum Steady Pressure

When using ASME B31.3 as the governing code, the following pressure and temperature rating issues must be addressed for the metal pipe to be specified:

- (1) For listed components having established rating, utilization of materials falling within the acceptable service ratings are listed in the codes and standards contained in Table 326.1 of ASME B31.3.
- (2) For listed components not having established ratings, utilization of components of the same materials with the same allowable stress as material specified in the codes and standards contained in Table 326.1, if the service ratings are based on straight seamless pipe and the pipe components to be utilized are not manufactured from straight seamless pipe. Because of this deviation from the listed rating, the pipe components should be rated using not more than 87.5% of the nominal wall thickness of the listed pipe less allowances applied to the pipe.

- (3) Unlisted components, components not listed in ASME B31.3 but conforming to other published standards, may be utilized if the requirements of the published standard are comparable to ASME B31.3 requirements and if the pressure design satisfies the ASME B31.3 pressure design of components.

b. Pressure Transients

Most design codes for metal pipe provide allowances for short duration transient conditions which do not increase the design pressure and temperature. When following ASME B31.3 or similar codes, the limitations of using these allowances without increasing the design conditions are typically specified within the code. Before finalizing the system design pressure and temperature, allowances for transient conditions within the applicable design code are reviewed and the anticipated conditions that would be covered by the allowances in the code are fully evaluated.

4-4. Piping Supports for Metallic Piping Systems

Specific metallic piping materials have particular requirements for the design of piping supports. Care should be taken to minimize stress in the pipe that may induce corrosion. Concentrated loads, such as valves, meters, and other fittings, should be independently supported. As a rule of thumb, spans for insulated lines should be reduced by approximately 30% from those for uninsulated pipes.

Tables 4-4 through 4-7 present support spacing examples for various metals. Calculations should be performed for each application since material strength varies by temper and manufacturing method. Table 4-4 summarizes support spacing for carbon and stainless steel pipe.

Support of nickel pipe should follow similar principles of other metallic piping systems. Table 4-5 summarizes support spacing for nickel 200 and nickel 201. Nickel 200 is pure wrought nickel. Nickel 201 is a low-carbon alloy of nickel 200, for higher temperature applications.

When designing aluminum pipe system supports, either aluminum or padded pipe supports should be specified. Aluminum will corrode when exposed to other metals. Contact with metals such as copper, brass, nickel, and carbon steel should be avoided. The support spacing for aluminum alloy 6063 pipe is summarized in Table 4-6.

**Table 4-4
Support Spacing for Steel Pipe**

Nominal Pipe Size, mm (in)	Maximum Support Spacing, m (ft)				
	SS, Sch 5S	SS, Sch 10S	CS, Sch 40	SS Sch 40S	CS Sch 80
15 (0.5)	2.9 (9.4)	2.9 (9.6)	2.1 (7.0)*	2.9 (9.6)	2.5 (8.3)
20 (0.75)	3.2 (10.3)	3.2 (10.6)	2.1 (7.0)*	3.3 (10.7)	2.9 (9.4)
25 (1)	3.4 (11.2)	3.6 (11.9)	2.1 (7.0)*	3.6 (12.0)	3.2 (10.5)
40 (1.5)	3.8 (12.6)	4.2 (13.8)	2.7 (9.0)*	4.3 (14.2)	3.9 (12.7)
50 (2)	4.1 (13.4)	4.5 (14.9)	3.0 (10.0)*	4.8 (15.6)	4.3 (14.1)
80 (3)	4.8 (15.7)	5.2 (17.1)	3.7 (12.0)*	5.8 (18.9)	5.2 (17.1)
100 (4)	5.0 (16.5)	5.6 (18.3)	4.3 (14.0)*	6.4 (21.0)	5.8 (19.2)
150 (6)	5.9 (19.4)	6.3 (20.6)	5.2 (17.0)*	7.5 (24.6)	7.0 (23.0)
200 (8)	6.2 (20.2)	6.8 (22.4)	5.8 (19.0)*	8.3 (27.4)	7.9 (25.8)
250 (10)	7.1 (23.3)	7.4 (24.1)	6.1 (22.0)*	9.1 (30.0)	8.7 (28.7)
300 (12)	7.4 (24.3)	7.8 (25.6)	7.0 (23.0)*	9.8 (32.2)	9.5 (31.1)

Notes:
 CS - electric resistance welded carbon steel ASTM A 53, grade A.
 SS - seamless stainless steel ASTM A 312, TP316L.
 Span lengths are based on a piping system that is a simple single span pipe run, is not insulated, has a full flow condition that is essentially water and is subject to a maximum operating condition of 93 °C (200 °F).
 *Maximum horizontal spacing based on MSS SP-69 (std. wt. steel pipe, water service)
 Source: Calculations by SAIC, 1998

**Table 4-5
Support Spacing for Nickel Pipe**

Nominal Pipe Size, mm (in)	Maximum Support Spacing, m (ft)					
	Ni 200, Sch 5	Ni 201, Sch 5	Ni 200, Sch 10	Ni 201, Sch 10	Ni 200, Sch 40	Ni 201, Sch 40
15 (0.5)	2.4 (7.8)	2.1 (6.9)	2.4 (7.9)	2.1 (6.9)	2.4 (7.9)	2.1 (6.9)
20 (0.75)	2.6 (8.6)	2.3 (7.5)	2.7 (8.8)	2.3 (7.7)	2.7 (8.8)	2.4 (7.8)
25 (1)	2.9 (9.4)	2.5 (8.2)	3.0 (9.8)	2.6 (8.6)	3.0 (9.9)	2.6 (8.7)
40 (1.5)	3.2 (10.6)	2.8 (9.3)	3.5 (11.5)	3.1 (10.1)	3.6 (11.8)	3.1 (10.3)
50 (2)	3.4 (11.3)	3.0 (9.9)	3.8 (12.5)	3.3 (10.9)	4.0 (13.0)	3.5 (11.4)
80 (3)	4.0 (13.2)	3.5 (11.6)	4.4 (14.4)	3.8 (12.6)	4.8 (15.7)	4.2 (13.8)
100 (4)	4.3 (14.0)	3.7 (12.3)	4.7 (15.4)	4.1 (13.6)	5.3 (17.5)	4.7 (15.3)
150 (6)	4.5 (14.7)	4.0 (13.2)	4.8 (15.6)	4.3 (14.0)	5.6 (18.4)	5.0 (16.4)
200 (8)	4.7 (15.4)	4.2 (13.8)	5.2 (17.0)	4.6 (15.2)	6.3 (20.5)	5.6 (18.4)
250 (10)	5.4 (17.8)	4.8 (15.9)	5.6 (18.3)	5.0 (16.4)	6.9 (22.5)	6.1 (20.1)
300 (12)	5.7 (18.5)	5.1 (16.6)	5.9 (19.4)	5.3 (17.4)	7.4 (24.2)	6.6 (21.6)

Notes:
 Ni 200 = seamless nickel ASTM B 161, alloy N02200, annealed.
 Ni 201 = seamless nickel ASTM B 161, alloy N02201, annealed.
 Span lengths are based on a piping system that is a simple single span pipe run, is not insulated, has a full flow condition that is essentially water and is subject to a maximum operating condition of 93 °C (200 °F).
 Source: Calculations by SAIC, 1998.

**Table 4-6
Support Spacing for Aluminum Pipe**

Nominal Pipe Size, mm (in)	Maximum Support Spacing, m (ft)			
	Al 6063, Sch 5	Al 6063, Sch 10	Al 6063, Sch 40	Al 6063, Sch 80
15 (0.5)	2.3 (7.6)	2.4 (8.0)	2.5 (8.3)	2.6 (8.5)
20 (0.75)	2.5 (8.1)	2.6 (8.6)	2.8 (9.1)	2.9 (9.4)
25 (1)	2.6 (8.5)	3.0 (9.7)	3.1 (10.1)	3.2 (10.5)
40 (1.5)	2.7 (9.0)	3.2 (10.6)	3.6 (11.4)	3.7 (12.2)
50 (2)	2.8 (9.3)	3.4 (11.1)	3.7 (12.3)	4.0 (13.3)
80 (3)	3.2 (10.7)	3.7 (12.2)	4.5 (14.7)	4.8 (15.9)
100 (4)	3.3 (10.9)	3.9 (12.6)	4.9 (16.0)	5.3 (17.5)
150 (6)	3.8 (12.6)	4.2 (13.8)	5.5 (18.1)	6.3 (20.5)
200 (8)	3.9 (12.9)	4.5 (14.7)	6.0 (19.8)	6.9 (22.7)
250 (10)	4.5 (14.8)	4.8 (15.6)	6.5 (21.4)	7.6 (25.0)
300 (12)	4.7 (15.4)	5.0 (16.4)	6.9 (22.7)	8.2 (27.1)

Notes:
 Al 6063 = seamless aluminum ASTM B 241 A96063, type T6 with welded joints.
 Span lengths are based on a piping system that is a simple single span pipe run, is not insulated, has a full flow condition that is essentially water and is subject to a maximum operating condition of 93 °C (200 °F).
 Source: Calculations by SAIC, 1998.

Design of copper pipe support follows principles similar to those for other metallic piping systems. Galvanic action between pipe supports and copper piping must be considered when specifying support materials. Table 4-7 summarizes support spacing for copper pipe.

4-5. Joining

Common methods for the joining of metallic pipe for liquid process systems include utilization of welded, flanged, threaded and mechanical joints including flared, flareless, compression, caulked, brazed and soldered joints. The application requirements and material specifications for these fittings are typically found in accompanying sections of the codes and standards used for the specification of the metallic pipe. The most common sources for application requirements and material specifications can be found in ASME, MSS and

API standards. Table 4-8 presents applicable sections of relevant codes and standards for the metallic fittings. In selecting a joining method for liquid process piping systems, the advantages and disadvantages of each method must be evaluated.

4-6. Thermal Expansion

Thermal expansion can impact the design of the piping system in the following critical areas: excessive stress related to thermal loads on the liquid being contained by the piping system, reduction of allowable stress due to elevated material temperature and stresses caused by elongation of the metal pipe; excessive thrust loads or bending moments at connected equipment due to thermal expansion of the metal pipe; and leaking at pipe joints due to thermal expansion of the metal pipe.

**Table 4-7
Support Spacing for Copper Pipe**

Nominal Pipe Size, mm (in)	Maximum Support Spacing, m (ft)		
	Cu Light Wall	Cu Regular Wall	Cu X-Strong Wall
15 (0.5)	1.5 (5.0)*	1.5 (5.0)*	1.5 (5.0)*
20 (0.75)	1.5 (5.0)*	1.5 (5.0)*	1.5 (5.0)*
25 (1)	1.8 (6.0)*	1.8 (6.0)*	1.8 (6.0)*
40 (1.5)	2.2 (7.3)	2.4 (8.0)*	2.4 (8.0)*
50 (2)	2.4 (7.8)	2.4 (8.0)*	2.4 (8.0)*
80 (3)	2.8 (9.2)	3.0 (10.0)*	3.0 (10.0)*
100 (4)	3.2 (10.4)	3.7 (12.0)*	3.7 (12.0)*
150 (6)	3.8 (12.6)	4.2 (13.9)	4.3 (14.0)*
200 (8)	4.5 (14.6)	4.8 (15.8)	4.9 (16.0)*
250 (10)	4.9 (16.1)	5.3 (17.4)	5.5 (18.0)*
300 (12)	5.4 (17.6)	5.9 (19.4)	--

Notes:
 Cu = seamless copper ASTM B 42, allow C 12200, drawn with brazed fittings.
 Span lengths are based on a piping system that is a simple single span pipe run, is not insulated, has a full flow condition that is essentially water and is subject to a maximum operating condition of 93 °C (200 °F).
 *Maximum horizontal spacing based on MSS SP-69 (copper tube, water service).
 Source: Calculations by SAIC, 1998.

Table 4-8
Applicable Codes for Metallic Fittings

Reference Standard	Key Aspects of Standard
API 605	Large Diameter Carbon Steel Flanges
ASME B16.1	Cast Iron Pipe Flanges and Flanged Fittings, Classes 25, 125, 250, and 800
ASME B16.5	Pipe Flanges and Flanged Fittings
ASME B16.9	Factory Made, Wrought Steel Butt-Welding Fittings
ASME B16.11	Forged Steel Fittings, Socket Welding and Threaded
ASME B16.24	Bronze Pipe Flanges and Flanged Fittings, Classes 150 and 300
ASME B16.25	Butt-Welding Ends
ASME B16.31	Non-Ferrous Pipe Flanges
ASME B31.3	Chemical Plant and Petroleum Refinery Piping - Chapter II Design Parts 3 and 4, Chapter III, Chapter IV, and Chapter V
ASME B16.42	Ductile Iron Pipe Flanges and Flanged Fittings, Classes 150 and 300
ASME B16.47	Large Diameter Steel Flanges
MSS SP-43	Wrought Stainless Steel Butt-welding Fittings
MSS SP-44	Steel Pipeline Flanges
MSS SP-51	Class 150 LW Corrosion Resistant Cost Flanges and Flanged Fittings
MSS SP-73	Brazing Joints for Wrought and Cast Copper Alloy Solder Joint Pressure Fittings
MSS SP-104	Wrought Copper Solder Joint Pressure Fittings
MSS SP-106	Cast Copper Alloy Flanges and Flanged Fittings, Class 125, 150 and 300
MSS SP-114	Corrosion Resistant Pipe Fittings Threaded and Socket Welding, Class 150 and 1000
MSS SP-119	Belled End Socket Welding Fittings, Stainless Steel and Copper Nickel
Source: Compiled by SAIC, 1998.	

When designing a piping system subject to thermal expansion due to anticipated operating temperatures and in which the piping is restrained at supports, anchors, equipment nozzles and penetrations, thermal stresses and loads may be large and must be analyzed and accounted for within the design. The system PFDs and P&IDs are analyzed to determine the thermal conditions or modes to which the piping system will be subjected to during operation. Based on this analysis, the design and material specification requirements are followed as an applicable standard.

The need for detailed thermal stress analysis is assessed for piping systems. An approach for this as-

essment is to first identify the operating conditions that will expose the piping to the most severe thermal loading conditions.

Once these conditions have been established, a free or unrestrained thermal analysis of the piping is performed. This analysis is performed by assuming no intermediate pipe supports, only terminal connections to anchors, equipment nozzles, and equipment penetrations. If, based on this analysis, the stress resulting from thermal expansion is less than 68.9 MPa (10 ksi), the pipe section analyzed has sufficient flexibility to accommodate the thermal expansion and rigid supports can be utilized. The terminal loadings on

equipment determined from this analysis can then be used to assess the equipment capabilities for withstanding the loading from the piping system. It should also be noted that this analysis at equipment and anchor terminations should consider the movement and stress impacts of the “cold” condition.

If the initial free thermal analysis indicates that the resulting stresses will require the piping system to be designed to accommodate thermal expansion, the design should conform to applicable codes and standards.

A basic approach to assess the need for additional thermal stress analysis for piping systems includes identifying operating conditions that will expose the piping to the most severe thermal loading conditions. Once these conditions have been established, a thermal analysis of the piping can be performed to establish location, sizing, and arrangement of expansion loops, or expansion joints (generally, bellows or slip types).

If the application requires the use of a bellow or piston joint, the manufacturer of the joint should be consulted to determine design and installation requirements. An alternative is an expansion loop. Expansion loops can be used in vertical or horizontal planes. If an expansion loop is to be required, the following formula can be used. This formula is based on guided-cantilever-beam theory in which both ends are fixed and limited pipe rotation is assumed. The loop is also geometrically similar (as depicted in Figure 2-3d) with the middle parallel leg equal to 1/2 of each of the tangential legs.

$$L = X + 2Y = (\Delta DE / C_1 S_A)^{0.5} \quad (\text{Metric Units})^1$$

or

$$L = X + 2Y = (3\Delta DE / (144 \text{ in.}^2/\text{ft}^2) S_A)^{0.5} \quad (\text{English Units})^2$$

where:

L = loop length to accommodate the thermal expansion, mm (ft)

X = parallel leg of loop, mm (ft)

$Y = 2X$ = tangential leg of loop, mm (ft)

D = actual outside pipe diameter, mm (in.)

¹ 1988 ASHRAE Handbook, EQUIPMENT

² 2000 ASHRAE Handbook, Heating, Ventilating, and Air-Conditioning, SYSTEMS AND EQUIPMENT

E = modulus of elasticity at the working temperature, kPa (psi)

S_A = maximum allowable stress at the working temperature, kPa (psi)

Δ = change in length due to temperature change, mm (in.)

C_1 = constant, 0.3333

ASHRAE states that for the commonly used A53 Grade B seamless or electric resistance welded (ERW) pipe, an allowable stress S_A of 155 MPa (22,500 psi) can be used without overstressing the pipe. However, this may result in very high end reactions and anchor forces, especially with large-diameter pipe. Designing to a stress range $S_A = 103$ MPa (15,000 psi) and assuming $E = 1.92 \times 10^5$ MPa (27.9×10^6 psi), the above equation reduces to:

$$L = 74.7(\Delta D)^{0.5} \quad (\text{Metric Units})$$

$$L = 6.225(\Delta D)^{0.5} \quad (\text{English Units})$$

This provides reasonably low end reactions without requiring too much extra pipe. In addition, this equation may be used with A53 butt-welded pipe and B88 drawn copper tubing.

When welded fittings are used in expansion loops rather than pipe bends, another important consideration is the effects of bending on the fittings used to install the expansion loop. The loop should be installed in consultation with the fitting manufacturer to ensure that specified fittings are capable of withstanding the anticipated loading conditions, constant and cyclic, at the design temperatures of the system. Terminal loadings on equipment determined from this analysis can then be used to assess the equipment capabilities for withstanding the loading from the piping system. It should also be noted that this termination analysis at equipment and anchor terminations should consider the movement and stress impacts of the “cold” condition.

Example Problem 7:

A 145-m-long (475-ft-long) steel, 200-mm (8-in.) diameter liquid process pipe operates at 90°C (194°F) and 1.55 MPa (225 psig). The expansion caused by the process stream must be absorbed using U-bends without damage to the pipe.

Solution:

Step 1. Establish a temperature differential (ΔT). Assume an installation temperature of 4.4°C (40°F). This would be a conservative, yet reasonable, assumption. Therefore, the temperature differential would be 90°C – 4.4°C, or 85.6°C (194°F – 40°F, or 154°F).

Step 2. Determine the thermal expansion (Δ).

$$\Delta = \alpha L_0(\Delta T)$$

where:

Δ = thermal expansion of pipe run, mm (in.)
 α = coefficient of thermal expansion, 11.7×10^{-6} mm/(mm °C), $(6.5 \times 10^{-6}$ in./[in. °F])³
 L_0 = original length of pipe run, mm (in.)
 ΔT = temperature differential

$$\Delta = 11.7 \times 10^{-6} \text{ mm/(mm °C)} \times 145,000 \text{ mm} \times 85.6^\circ\text{C}$$

$$(6.5 \times 10^{-6} \text{ in./[in. °F]} \times 5700 \text{ in} \times 154^\circ\text{F})$$

$$\Delta = 145.2 \text{ mm}$$

$$(5.71 \text{ in.})$$

Step 3. Determine dimensions of expansion loop. The expansion loop is centered between anchored supports as schematically shown in Figure 2-3d.

$$L = X + 2Y = 74.7(\Delta D)^{0.5} \quad 6.225(\Delta D)^{0.5}$$

and

$$Y = 2X$$

So

$$L = 5X = 74.7(145.2 \text{ mm} \times 220 \text{ mm})^{0.5}$$

$$6.225 (5.71 \text{ in.} \times 8.625 \text{ in.})^{0.5}$$

$$L = 5X = 13,351 \text{ mm} \quad (43.7 \text{ ft})$$

$$X = 2670 \text{ mm} \quad (8.74 \text{ ft})$$

$$Y = 2(2670 \text{ mm}) = 5340 \text{ mm} \quad (17.5 \text{ ft})$$

The length of the parallel leg of the expansion loop is 2670 mm (8.74 ft), and the length of each of the two tangential legs of the expansion loop is 5340 mm (17.5 ft).

4-7. Ductile Iron

³ Design of Machine Elements, 5th Edition, Spotts, M.F., Tables 2-1, 2-1A, Prentice Hall, 1978.

Ductile iron is a hard, nonmalleable ferrous metal that must be molded into the various component shapes. It is used for those piping applications requiring strength, shock resistance, and machinability. It has good resistance to general corrosion, but reacts readily with hydrogen sulfide.

a. Ductile Iron Specifications

Due to the long use of ductile iron in water service, ductile iron piping is most commonly specified pursuant to AWWA standards. As noted in Paragraph 3-5, care must be taken when joining AWWA piping systems to ASME piping systems.

4-8. Carbon Steel

Carbon steel is a hot-rolled, all-purpose material. It is the most common and economical metal used in industry. It will readily rust (corrode) in ambient atmospheres, and therefore casting applications should be considered. It will also become embrittled with prolonged contact with alkaline or strong caustic fluids and contact with acid accelerates corrosion. It may react directly with hydrogen sulfide gas. The material/fluid matrix in Appendix B should be consulted for each application.

a. Carbon Steel Pipe Specifications

A wide variety of mechanical properties is available by varying the carbon content and heat treatments. The most commonly specified carbon steel piping is manufactured to meet ASTM A 53. The type and grade of the pipe must be specified: type F (furnace-butt-welded), grade A; type E (electric-resistance welded), grade A or B; or type S (seamless), grade A or B. Type F should not be used if flanging is required, and grade A is preferred if cold-bending is to occur. Options that can be specified pursuant to ASTM A 53 include hot-dip galvanizing, threaded ends and dimensions, schedule 40, 80, 160 and others that may be available depending on pipe diameter.

Many other options exist. For example, ASTM A 587 specifies an electric-resistance welded carbon steel pipe intended for use in the chemical industry. The material is low-carbon and can also be specified for galvanizing; either of these factors will reduce corrosion effects. The pipe is available in two nominal wall thicknesses from 15 mm (½ in.) to 250 mm (10 in.) in diameter. Another carbon steel pipe standard is ASTM A 106 which specifies seamless carbon steel pipe for high temperature service, but

graphitization at prolonged high temperature may still occur. Additional manufacturing standards for specialized carbon steel piping include, but are not limited to: ASTM A 135, schedule 10 electric-resistance welded carbon steel pipe; ASTM A 333, seamless or welded carbon steel (and low-alloy steel) pipe for low temperature service; and ASTM A 691, 405 mm (16 in.) and larger diameter electric-fusion welded carbon steel (and low-alloy steel) pipe for high pressure service at high temperatures. ASTM standards are reviewed for unusual process conditions or requirements to select the material most compatible to the application.

b. Carbon Steel Fittings

Fittings for carbon steel piping can be threaded, welded or flanged; all are commonly used. Fitting materials can be cast malleable iron, forged carbon steel and low-carbon or other specialized steel. In non-corrosive applications with threaded fittings, malleable iron conforming to ASTM A 47 is typically used. However, as the process dictates, forged carbon steel threaded fittings pursuant to ASTM A 105 are applicable for ambient to high temperature service, and low-carbon steel threaded fittings pursuant to ASTM A 858 are applicable for ambient to low temperature or corrosive service. Welded fittings can be butt-welded or socket welded with ASTM A 105 or ASTM A 858 conforming materials. Malleable iron is not welded. Other ASTM materials may also be appropriate; select a material and fitting that are compatible to the application.

Due to the relative inexpense of carbon steel flanges, carbon steel piping is usually flanged at connections to equipment and appurtenances such as valves or other items that may have to be removed or replaced. Common flange material is ASTM A 105 forged carbon steel for ambient to high temperature and ASTM A 727 forged carbon steel for temperatures between -30EC (-20EF) and 345EC (650EF).

In addition to fittings described above, carbon steel piping may be joined by mechanical couplings. The pipe sections must, however, be specified with grooved ends. Most of the manufacturers that produce mechanical couplings for ductile iron piping also produce them for carbon steel piping.

4-9. Stainless Steel

Stainless steel is the product of steel alloyed with chromium and, to a lesser extent, nickel. Other elements such as molybdenum, copper, manganese and

silicon may also be included as part of the alloy for various steel types. Chromium is the primary additive that makes steel “stainless”; stainless steels are actually a very broad range of highly corrosion-resistant alloys that have a variety of trace elements.

a. Stainless Steel Types

The most common types of stainless steel used for liquid process applications are 304 and 316. One caution: stainless steel is not totally corrosion resistant. Chemicals such as sodium bisulfide, ferric chloride, ozone and hydrochloric acid can attack stainless steel successfully. Check the material/fluid matrix in Appendix B for compatibility with the application. The most commonly used series for corrosion resistance are discussed below.

Types 304 and 304L are austenitic stainless steels that provide outstanding resistance to bases such as lime and sodium hydroxide. They are highly resistant to many acids, including hot or cold nitric. Types 316 and 316L are stainless steel types that exhibit better resistance to sulfides and chlorides than 304 and 304L, and will provide adequate resistance to corrosion from sulfuric acid. Otherwise, 316 and 316L provide the same outstanding resistance to acids and bases as 304 and 304L. The “L” designation indicates alloys developed to minimize post-welding intergranular corrosion, and these alloys are strongly recommended whenever welding is involved. In general, the “L” stainless steels provide more resistance to sulfuric acid/nitric acid mixed solutions than non-low carbon steels.

Austenitic stainless steel piping is commonly specified to conform to ASTM A 312, ASTM A 813 or ASTM A 814. All three of these standards address austenitic stainless steel pipe intended for general corrosive and/or high temperature service. ASTM A 312 specifies seamless and straight-seam welded pipe; ASTM A 813 covers straight-seam single- or double-welded pipe that is of fit-up and alignment quality; and ASTM A 814 addresses flanged and cold-bending quality (cold worked) straight-seam single- or double-welded pipe.

Austenitic stainless steel fittings may be threaded, welded or flanged. The materials should match the associated pipe. For example, WP316L fittings or F316L flanges should be used with type 316L pipe. Welding fittings are typically specified under ASTM A 403. Class WP welding fittings are standard use as they conform to ASME B16.9 and ASME B16.11. Class CR welding fittings are light weight and con-

form to MSS SP-43. Threaded and flanged fittings are commonly specified under ASTM A 182.

Ferritic and martensitic stainless steels are used less commonly than austenitic. Unlike austenitic steels, ferritic stainless steels do not contain nickel and do not resist reducing chemicals such as hydrochloric acids. Ferritic stainless steels have excellent resistance to chloride attack and organic acids.⁴ A commonly used ferritic stainless steel is type 430. Martensitic stainless steels, however, may contain nickel because their chromium content is limited. Typically, martensitic steels exhibit less corrosion resistance than austenitic steels.

Ferritic and martensitic stainless steel piping should conform to ASTM A 731, which addresses both seamless and welded pipe intended for general corrosive and high-temperature service. Welding fittings are typically specified under ASTM A 815 as Class WP or CR similar to austenitic stainless steel fittings. Threaded and flanged fittings are specified in accordance with ASTM A 182.

b. Stainless Steel Pipe Construction

Standard nominal pipe sizes are 15 through 300 mm (½ through 12 in.) commonly available in schedules 5S, 10S, 40S and 80S. Schedule 5S and 10S piping can not be threaded due to wall thickness constraints.

4-10. Nickel and Nickel Alloys

Nickel is used for its strong resistance to certain corrosive chemicals.

a. Common Alloys

Refer to the corrosion compatibility tables for specific applications of these alloys. Although other nickel alloys are used for specialty applications, these are the more commonly prescribed.

Alloy 200 is commercially pure wrought nickel, and 201 is a low-carbon version of 200 that is used for applications above 315EC (600EF). Corrosion resistances are the same for both alloys. They are resistant to caustic soda and most alkalis (key exception: ammonium hydroxide). They are not subject to stress corrosion in chloride salts. They are excellent for dry handling of chlorine and hydrogen chloride at elevated temperatures.

⁴ Schweitzer, *Corrosion-Resistant Piping Systems*, p. 234.

Nickel alloy 200 and 201 pipe can be specified seamless or welded. Cold-worked seamless pipe is readily available in nominal pipe sizes 6 mm (1/8 in.) to 200 mm (8 in.), dimensioned as schedule 5, 10, 40, or 80, pursuant to ASTM B 161 and ASTM B 829. Welded pipe, intended for corrosive service, is manufactured in accordance with ASTM B 725 and B 775, and is readily available in nominal pipe sizes 6 mm (1/8 in.) to 750 mm (30 in.), dimensioned as schedule 5S, 10S, and 40S. The material condition must be specified for both seamless and welded pipe as annealed or stress relieved. The latter conditioning provides more tensile strength. For example, the tensile strength for a seamless alloy 200 pipe is 380 MPa (55,000 psi) annealed and 450 MPa (65,000 psi) stress relieved.

Hastelloy, a nickel-molybdenum-chromium alloy, offers excellent resistance to wet chlorine, hypochlorite bleach, ferric chloride and nitric acid. Hastelloy, and related alloys, can be seamless or welded. Seamless pipe is manufactured pursuant to ASTM B 622 and ASTM B 829, and is readily available in nominal pipe sizes 8 mm (1/4 in.) to 80 mm (3 in.), dimensioned to schedule 10, 40, or 80. Welded pipe is readily available in nominal pipe sizes 6 mm (1/8 in.) to 200 mm (8 in.), dimensioned to 5S, 10S, 40S, and 80S, pursuant to ASTM B 619 and ASTM B 775. The material class is specified as class 1 or 2. Class 1 pipe is welded and solution annealed, and class 2 is welded, cold-worked and then solution annealed. Class 1 pipe may have sunken welds up to 15% of the wall thickness, while class 2 pipe does not have sunken welds.

Monel, a nickel-copper alloy, combines high strength with high ductility (usually a tradeoff in metals selection), as well as excellent general corrosion resistance. It is specified particularly where seawater or industrial chemicals may be accompanied by high temperatures. It must not be exposed, when hot, to sulfur or molten metals.

Monel can also be provided either seamless or welded. Seamless, cold-worked pipe is available in nominal pipe sizes 6 mm (1/8 in.) to 200 mm (8 in.), dimensioned to schedule 5, 10, 40, or 80, pursuant to ASTM B 165 and ASTM B 829. Welded Monel, intended for general corrosive service, is manufactured in accordance with ASTM B 725 and ASTM B 775, and is readily available in nominal pipe sizes 6 mm (1/8 in.) to 750 mm (30 in.), dimensioned as schedules 5S, 10S, and 40S. The pipe material conditioning, either annealed or stress relieved, should be specified.

Inconel, a nickel-chromium-iron alloy, is noted for having high temperature strength, while maintaining excellent corrosion resistance. Similar to all the nickel and nickel alloy piping systems, Inconel pipe can be provided either seamless or welded. Seamless Inconel pipe is available in nominal pipe sizes 8 mm (1/4 in.) to 150 mm (6 in.), dimensioned to schedule 5, 10, 40 or 80. It is manufactured pursuant to ASTM B 167 and ASTM B 829. The material conditioning should be specified; hot-worked, hot-worked annealed or cold-worked annealed. The conditioning determines tensile strength; for example, the tensile strength of a 150 mm (6 in.) seamless Inconel pipe is 515 MPa (75,000 psi) for hot-worked and hot-worked annealed tempering and is 550 MPa (80,000 psi) for cold-worked annealed tempering. Welded Inconel pipe, intended for general corrosive and heat resisting applications, is produced in accordance with ASTM B 517 and ASTM B 775. Manufacturers will have to be contacted to confirm available sizes and schedules.

b. Nickel and Nickel Alloy Fittings

Welding and threaded fittings for nickel and nickel alloy piping systems are manufactured in conformance with ASTM B 366. Threaded fittings meet ASME B 16.11. Welding fittings can be class WP, which conforms to ASME B 16.9, ASME B 16.11 and ASME B 16.28, or class CR which are light weight and conform to MSS SP-43. Flanges are commonly specified to ASTM B 564 (and ASTM B 160 for nickel alloys 200 and 201), annealed temper only. Fitting dimensions and ratings are specified pursuant to ASME standards.

4-11. Aluminum

Aluminum is highly ductile. Although it has relatively low strength, its high strength-to-weight ratio results in the extensive use of aluminum alloys where that feature is required.

a. Aluminum Pipe Use

Alloys 1060, 3003, 5052, 6061, and 6063 are the most common compositions of its aluminum pipe. Alloy 6063 is most widely used due to cost, good corrosion resistance, and mechanical properties. Alloys 3003 and 5052 are best used for extremely low temperatures. Alloy 5052 has the best corrosion resistance for slightly alkaline solutions.⁵

⁵ Schweitzer, *Corrosion-Resistant Piping Systems*, p. 253.

Aluminum piping resists corrosion well by forming a protective aluminum oxide film. Refer to the fluid/material matrix in Appendix B for compatibility applications. It is very resistant to sulfur compounds and most organics, including halogenated organic compounds. Aluminum should not, however, directly contact concrete because alkalis in the concrete will attack the aluminum. One note of caution is that resistance of aluminum to some combinations of compounds is poor, even though aluminum may be strongly resistant to each compound in the mixture. An example would be strong resistance to either carbon tetrachloride or methyl alcohol separately, but poor resistance to a mixture of the two. Also, aluminum has poor resistance to contaminants such as halide ions (like chloride) and reducible metals (like copper) contained in commercial chemical grades of some chemicals. Aluminum piping is not compatible with most inorganic acids, bases and salts outside a pH range of approximately 4 to 9. In addition, nearly all dry acids, alcohols and phenols near their boiling points can cause excessive aluminum corrosion.⁶

b. Aluminum Pipe Construction

All alloys are available in nominal pipe sizes from 15 mm (1/2 in.) to 300 mm (12 in.), in schedules 5, 10, 40 and 80. The preferred method for joining aluminum pipe to handle corrosives is welding; however, welding reduces tensile strength. Only schedule 40 and 80 pipe can be threaded. Threading is not recommended for aluminum piping systems that handle corrosives. Flanges are not normally used to join pipe sections and should be limited to connecting aluminum pipe to equipment such as pumps and process vessels.

Aluminum piping materials are most commonly specified using ASTM B 241. This standard covers seamless pipe intended for pressure applications and includes many aluminum alloys and tempering options. The temper required to obtain the proper tensile strength must be specified. For example, temper T6 is the strongest tensile strength for alloy 6063—206.8 MPa (30,000 psi). As an option, pipe lengths specified by ASTM B 241 may also have threaded ends.

Aluminum piping materials may also be specified to meet ASTM B 345 which covers seamless pipe for internal pressure applications. The number of alloys and tempers available under this standard is less than ASTM B 241. However, additional options for pipe

⁶ *Ibid.*, p. 254.

length ends exist, including threaded, beveled, grooved, or specialty end configurations such as the V-groove or modified Vee. If used with end configurations for mechanical coupling, the burden of mating the end configuration with the mechanical coupling used should be placed on the coupling supplier in the specifications.

Welding fittings are addressed in ASTM B 361, and threaded or flanged fittings materials are forged in accordance with ASTM B 247. Dimensions and configurations for the fittings should reference the appropriate ASME standard(s).

4-12. Copper

Copper is very ductile and malleable metal and does not corrode easily in normal wet/dry environments. Being a noble metal, it does not normally displace hydrogen from a solution containing hydrogen ions. However, copper corrodes rapidly when exposed to oxidizing agents such as chlorine, ozone, hydrogen sulfide, nitric acid and chromic acid. It is very susceptible to galvanic action, and this demands that padded pipe hangers are used and that attention is paid to contact with dissimilar metals.

a. Copper Pipe Construction

Seamless copper pipe is specified pursuant to ASME B 42. Various alloys and tempers may be selected. The copper alloys vary based upon the oxygen and phosphorus contents, and temper is selected based on required tensile strength. Nominal pipe sizes range from 6 mm (1/8 in.) to 300 mm (12 in.), in three wall thicknesses: light, regular, and extra strong.

Other options for copper based piping exist. For example, ASTM B 608 provides copper alloys that contain nickel for brackish or sea water applications with nominal pipe sizes from 100 mm (4 in.) to 1,200 mm (48 in.). In addition, aluminum-bronze, copper-nickel and red brass piping materials are also available.

b. Copper and Copper Alloy Fittings

Flanges and fittings for copper piping systems are component casted. The material is typically produced in accordance with ASTM B 61 for high-grade metal (used in limited steam applications) and for valve-bronze alloys, or with ASTM B 62 for a lesser grade alloy. Configuration and pressure ratings must be specified pursuant to ASME standards.

Chapter 5 Plastic Piping Systems

5-1. General

Thermoplastic piping systems, commonly referred to as plastic piping systems, are composed of various additives to a base resin or composition. Thermoplastics are characterized by their ability to be softened and reshaped repeatedly by the application of heat. Table 5-1 lists the chemical names and abbreviations for a number of thermoplastic piping materials. Because of the slightly different formulations, properties of plastic piping materials (for example, polyvinyl chloride - PVC) may vary from manufacturer to manufacturer¹. Therefore, designs and specifications need to address specific material requirements on a type or grade basis, which may have to be investigated and confirmed with manufacturers.

a. Corrosion

Unlike metallic piping, thermoplastic materials do not display corrosion rates². That is, the corrosion of thermoplastic materials is dependent totally on the material's chemical resistance rather than an oxide layer, so the material is either completely resistant to a chemical or it deteriorates. This deterioration may be either rapid or slow. Plastic piping system corrosion is indicated by material softening, discoloration, charring, embrittlement, stress cracking (also referred to as crazing), blistering, swelling, dissolving, and other effects. Corrosion of plastics occurs by the following mechanisms:

- absorption;
- solvation;
- chemical reactions such as oxidation (affects chemical bonds), hydrolysis (affects ester linkages), radiation, dehydration, alkylation, reduction, and halogenation (chlorination);

Table 5-1 Abbreviations for Thermoplastic Materials	
Abbreviation	Chemical Name
ABS	Acrylonitrile-Butadiene-Styrene
CPVC	Chlorinated Poly(Vinyl Chloride)
ECTFE	Ethylene-Chlorotrifluoroethylene
ETFE	Ethylene-Tetrafluoroethylene
FEP	Perfluoro(Ethylene-Propylene) Copolymer
PE	Polyethylene
PFA	Perfluoro(Alkoxyalkane) Copolymer
PP	Polypropylene
PTFE	Polytetrafluoroethylene
PVC	Poly(Vinyl Chloride)
PVDC	Poly(Vinylidene Chloride)
PVDF	Poly(Vinylidene Fluoride)
Sources: ASTM D 1600. ASME B31.3 (Used by permission of ASME).	

¹ Schweitzer, *Corrosion-Resistant Piping Systems*, p. 17.

² *Ibid.*, p. 18.

- thermal degradation which may result in either depolymerization or plasticization;
- environmental-stress cracking (ESC) which is essentially the same as stress-corrosion cracking in metals;
- UV degradation; and - combinations of the above mechanisms.

For plastic material compatibility with various chemicals, see Appendix B. If reinforcing is used as part of the piping system, the reinforcement is also a material that is resistant to the fluid being transported. Material selection and compatibility review should consider the type and concentration of chemicals in the liquid, liquid temperature, duration of contact, total stress of the piping system, and the contact surface quality of the piping system. See Appendix A, paragraph A-4 - Other Sources of Information, for additional sources of corrosion data.

b. Operating Pressures and Temperatures

The determination of maximum steady state design pressure and temperature is similar to that described for metallic piping systems. However, a key issue that must be addressed relative to plastic piping systems is the impact of both minimum and maximum temperature limits of the materials of construction.

c. Sizing

The sizing for plastic piping systems is performed consistent with the procedures of Paragraph 3-3. However, one of the basic principles of designing and specifying thermoplastic piping systems for liquid process piping pressure applications is that the short and long term strength of thermoplastic pipe decreases as the temperature of the pipe material increases.

Thermoplastic pipe is pressure rated by using the International Standards Organization (ISO) rating equation using the Hydrostatic Design Basis (HDB) as contained in ASTM standards and Design Factors (DFs). The use of DFs is based on the specific material being used and specific application requirements such as temperature and pressure surges. The following is the basic equation for internal hydraulic pressure rating of thermoplastic piping:

$$P_R = 2(HDS)(t/D_m)$$

where:

- P_R = pipe pressure rating, MPa (psi)
- t = minimum wall thickness, mm (in)
- D_m = mean diameter, mm (in)
- HDS = (HDB)(DF)

The minimum pipe wall thickness can also be determined using the requirements of ASME B31.3 as described in Paragraph 3-3b. This procedure is not directly applicable to thermoplastic pipe fittings, particularly in cyclic pressure operations due to material fatigue. Therefore, it should not be assumed that thermoplastic fittings labeled with a pipe schedule designation will have the same pressure rating as pipe of the same designation. A good example of this is contained in ASTM D 2466 and D 2467 which specify pressure ratings for PVC schedule 40 and 80 fittings. These ratings are significantly lower than the rating for PVC pipe of the same designation. For thermoplastic pipe fittings that do not have published pressure ratings information similar to ASTM standards, the fitting manufacturer shall be consulted for fitting pressure rating recommendations.

d. Joining

Common methods for the joining of thermoplastic pipe for liquid process waste treatment and storage systems are contained in Table 5-2. In selecting a joining method for liquid process piping systems, the advantages and disadvantages of each method are evaluated and the manner by which the joining is accomplished for each liquid service is specified. Recommended procedures and specification for these joining methods are found in codes, standards and manufacturer procedures for joining thermoplastic pipe. Table 5-3 lists applicable references for joining thermoplastic pipe.

e. Thermal Expansion

When designing a piping system where thermal expansion of the piping is restrained at supports, anchors, equipment nozzles and penetrations, large thermal stresses and loads must be analyzed and accounted for within the design. The system PFDs and P&IDs are analyzed to determine the thermal conditions or modes to

Table 5-2 Thermoplastic Joining Methods						
Joining Method	ABS	PVC	CPVC	PE	PP	PVDF
Solvent Cementing	X	X	X			
Heat Fusion				X	X	X
Threading*	X	X	X	X	X	X
Flanged Connectors**	X	X	X	X	X	X
Grooved Joints***	X	X	X	X	X	X
Mechanical Compression****	X	X	X	X	X	X
Elastomeric seal	X	X	X	X	X	X
Flaring				X		

Notes:
 X = applicable method
 * Threading requires a minimum pipe wall thickness (Schedule 80).
 ** Flanged adapters are fastened to pipe by heat fusion, solvent cementing, or threading.
 *** Grooving requires a minimum pipe wall thickness (material dependent).
 **** Internal stiffeners are required.
 Source: Compiled by SAIC, 1998.

Table 5-3 Thermoplastic Joining Standards	
Reference	Key Aspects of Reference
ASTM D 2657	Recommended practice for heat fusion.
ASTM D 2855	Standard practice for solvent cementing PVC pipe and fittings.
ASTM D 3139	Elastomeric gasketed connections for pressure applications.
ASTM F 1290	Recommended practice for electrofusion.

Source: Compiled by SAIC, 1998.

which the piping system will be subjected during operation. Based on this analysis, the design and material specification requirements from an applicable standard or design reference are followed in the design.

A basic approach to assess the need for additional thermal stress analysis for piping systems includes

identifying operating conditions that will expose the piping to the most severe thermal loading conditions. Once these conditions have been established, a free or unrestrained thermal analysis of the piping can be performed to establish location, sizing, and arrangement of expansion loops, or expansion joints (generally, bellows or slip types).

If the application requires the use of a bellow or piston joint, the manufacturer of the joint shall be consulted to determine design and installation requirements.

When expansion loops are used, the effects of bending on the fittings used to install the expansion loop are considered. Installation of the loop should be performed in consultation with the fitting manufacturer to ensure that specified fittings are capable of withstanding the anticipated loading conditions, constant and cyclic, at the design temperatures of the system. Terminal loadings on equipment determined from this analysis can then be used to assess the equipment capabilities for withstanding the loading from the piping system. It should also be noted that this termination analysis at equipment and anchor terminations should consider the movement and stress impacts of the "cold" condition.

No rigid or restraining supports or connections should be made within the developed length of an expansion loop, offset, bend or branch. Concentrated loads such as valves should not be installed in the developed length. Piping support guides should restrict lateral movement and should direct axial movement into the compensating configurations. Calculated support guide spacing distances for offsets and bends should not exceed recommended hanging support spacing for the maximum temperature. If that occurs, distance between anchors will have to be decreased until the support guide spacing distance equals or is less than the recommended support spacing. Use of the rule of thumb method or calculated method is not recommended for threaded Schedule 80 connections. Properly cemented socket cement joints should be utilized.

Expansion loops, offsets and bends should be installed as nearly as possible at the mid point between anchors.

Values for expansion joints, offsets, bends and branches can be obtained by calculating the developed length from the following equation.

$$L = n_1 \left(\frac{3 E D_o e}{S} \right)^{1/2}$$

where:

L = developed length, m (ft)

n₁ = conversion factor, 10⁻³ m/mm (1/12 ft/in)

E = tensile modulus of elasticity, MPa (psi)

D_o = pipe outer diameter, mm (in)

e = elongation due to temperature rise, mm (in)

S = maximum allowable stress, MPa (psi)

In determining the elongation due to temperature rise information from the manufacturer on the material to be used should be consulted. For example, the coefficient of expansion is 6.3 x 10⁻⁵ mm/mm/°C (3.4 x 10⁻⁵ in/in/°F) for Type IV Grade I CPVC and 5.4 x 10⁻⁵ mm/mm/°C (2.9 x 10⁻⁵ in/in/°F) for Type I Grade I PVC. Other sources of information on thermal expansion coefficients are available from plastic pipe manufacturers.

PVC and CPVC pipe does not have the rigidity of metal pipe and can flex during expansion, especially with smaller diameters. If expansion joints are used, axial guides should be installed to ensure straight entrance into the expansion joint, especially when maximum movement of the joint is anticipated. Leakage at the seals can occur if the pipe is cocked. Independent anchoring of the joint is also recommended for positive movement of expansion joints.

f. Piping Support and Burial

Support for thermoplastic pipe follows the same basic principles as metallic piping. Spacing of supports is crucial for plastic pipe. Plastic pipe will deflect under load more than metallic pipe. Excessive deflection will lead to structural failure. Therefore, spacing for plastic pipe is closer than for metallic pipe. Valves, meters, and fittings should be supported independently in plastic pipe systems, as in metallic systems.

In addition, plastic pipe systems are not located near sources of excessive heat. The nature of thermoplastic pipe is that it is capable of being repeatedly softened by increasing temperature, and hardened by decreasing temperature. If the pipe is exposed to higher than design value ambient temperatures, the integrity of the system could be compromised.

Contact with supports should be such that the plastic pipe material is not damaged or excessively stressed. Point contact or sharp surfaces are avoided as they may impose excessive stress on the pipe or otherwise damage it.

Support hangers are designed to minimize stress concentrations in plastic pipe systems. Spacing of

supports should be such that clusters of fittings or concentrated loads are adequately supported. Valves, meters, and other miscellaneous fittings should be supported exclusive of pipe sections.

Supports for plastic pipe and various valves, meters, and fittings, should allow for axial movement caused by thermal expansion and contraction. In addition, external stresses should not be transferred to the pipe system through the support members. Supports should allow for axial movement, but not lateral movement. When a pipeline changes direction, such as through a 90° elbow, the plastic pipe should be rigidly anchored near the elbow.

Plastic pipe systems should be isolated from sources of vibration, such as pumps and motors. Vibrations can negatively influence the integrity of the piping system, particularly at joints.

Support spacing for several types of plastic pipe are found in Tables 5-4 through 5-6. Spacing is dependent upon the temperature of the fluid being carried by the pipe.

The determining factor to consider in designing buried thermoplastic piping is the maximum allowable deflection in the pipe. The deflection is a function of the bedding conditions and the load on the pipe. The procedure for determining deflection is as follows³:

$$\% \text{ deflection} = \frac{100 \Delta Y}{D_o}$$

where:

ΔY = calculated deflection
 D_o = outer pipe diameter, mm (in)

$$\Delta Y = \frac{(K_x)(d_e)(\Gamma)}{[0.149(PS) + 0.061(E')]}$$

where:

ΔY = calculated deflection
 K_x = bedding factor, see Table 5-7
 d_e = deflection lag factor, see Table 5-8
 Γ = weight per length of overburden, N/m (lb/in)

PS = pipe stiffness, MPa (psi)
 E' = soil modulus, MPa (psi), see Table 5-9

$$\Gamma = \frac{(H)(D_o)(\gamma)}{144} = (\Omega)(D_o)$$

where:

Γ = weight per length of overburden, N/m (lb/in)
 H = height of cover, m (ft)
 D_o = outer pipe diameter, mm (in)
 γ = density of soil N/m³ (lb/ft³)
 Ω = soil overburden pressure, MPa (psi)

$$PS = \frac{(E)(I_a)}{0.149 (R)^3}$$

where:

PS = pipe stiffness, MPa (psi)
 E = modulus of elasticity of pipe, MPa (psi)
 I_a = area moment of inertia per unit length of pipe, mm⁴/mm (in⁴/in)
 R = mean radii of pipe, MPa (psi)

$$R = \frac{(D_o - t)}{2}$$

where:

R = mean radii of pipe, MPa (psi)
 D_o = outer pipe diameter, mm (in)
 t = average wall thickness, mm (in)

$$I_a = \frac{t^3}{12}$$

where:

I_a = area moment of inertia per unit length of pipe, mm⁴/mm (in⁴/in)
 t = average wall thickness, mm (in)

Proper excavation, placement, and backfill of buried plastic pipe is crucial to the structural integrity of the system. It is also the riskiest operation, as a leak in the system may not be detected before contamination has occurred. A proper bed, or trench, for the pipe is the initial step in the process. In cold weather areas, underground pipelines should be placed no less than one

³ ASTM D 2412, Appendices.

Table 5-4 Support Spacing for Schedule 80 PVC Pipe					
Nominal Pipe Size, mm (in)	Maximum Support Spacing, m (ft) at Various Temperatures				
	16°C (60°F)	27°C (80°F)	38°C (100°F)	49°C (120°F)	60°C (140°F)*
25 (1)	1.83 (6.0)	1.68 (5.5)	1.52 (5.0)	1.07 (3.5)	0.91 (3.0)
40 (1.5)	1.98 (6.5)	1.83 (6.0)	1.68 (5.5)	1.07 (3.5)	1.07 (3.5)
50 (2)	2.13 (7.0)	1.98 (6.5)	1.83 (6.0)	1.22 (4.0)	1.07 (3.5)
80 (3)	2.44 (8.0)	2.29 (7.5)	2.13 (7.0)	1.37 (4.5)	1.22 (4.0)
100 (4)	2.74 (9.0)	2.59 (8.5)	2.29 (7.5)	1.52 (5.0)	1.37 (4.5)
150 (6)	3.05 (10.0)	2.90 (9.5)	2.74 (9.0)	1.83 (6.0)	1.52 (5.0)
200 (8)	3.35 (11.0)	3.2 (10.5)	2.90 (9.5)	1.98 (6.5)	1.68 (5.5)
250 (10)	3.66 (12.0)	3.35 (11.0)	3.05 (10.0)	2.13 (7.0)	1.83 (6.0)
300 (12)	3.96 (13.0)	3.66 (12.0)	3.2 (10.5)	2.29 (7.5)	1.98 (6.5)
350 (14)	4.11 (13.5)	3.96 (13.0)	3.35 (11.0)	2.44 (8.0)	2.13 (7.0)

Note: The above spacing values are based on test data developed by the manufacturer for the specific product and continuous spans. The piping is insulated and is full of liquid that has a specific gravity of 1.0.
 * The use of continuous supports or a change of material (e.g., to CPVC) is recommended at 60°C (140°F).
 Source: Harvel Plastics, Product Bulletin 112/401 (rev. 10/1/95), p. 63.

Table 5-5 Support Spacing for Schedule 80 PVDF Pipe				
Nominal Pipe Size, mm (in)	Maximum Support Spacing, m (ft) at Various Temperatures			
	20°C (68°F)	40°C (104°F)	60°C (140°F)	80°C (176°F)
25 (1)	1.07 (3.5)	0.91 (3.0)	0.91 (3.0)	0.76 (2.5)
40 (1.5)	1.22 (4.0)	0.91 (3.0)	0.91 (3.0)	0.91 (3.0)
50 (2)	1.37 (4.5)	1.22 (4.0)	0.91 (3.0)	0.91 (3.0)
80 (3)	1.68 (5.5)	1.22 (4.0)	1.22 (4.0)	1.07 (3.5)
100 (4)	1.83 (6.0)	1.52 (5.0)	1.22 (4.0)	1.22 (4.0)
150 (6)	2.13 (7.0)	1.83 (6.0)	1.52 (5.0)	1.37 (4.5)

Note: The above spacing values are based on test data developed by the manufacturer for the specific product and continuous spans. The piping is insulated and is full of liquid that has a specific gravity of 1.0.
 Source: Asahi/America, Piping Systems Product Bulletin P-97/A, p. 24.

Table 5-6 Support Spacing for Schedule 80 CPVC Pipe						
Nominal Pipe Size, mm (in)	Maximum Support Spacing, m (ft) at Various Temperatures					
	23°C (73°F)	38°C (100°F)	49°C (120°F)	60°C (140°F)	71°C (160°F)	82°C (180°F)
25 (1)	1.83 (6.0)	1.83 (6.0)	1.68 (5.5)	1.52 (5.0)	1.07 (3.5)	0.91 (3.0)
40 (1.5)	2.13 (7.0)	1.98 (6.5)	1.83 (6.0)	1.68 (5.5)	1.07 (3.5)	0.91 (3.0)
50 (2)	2.13 (7.0)	2.13 (7.0)	1.98 (6.5)	1.83 (6.0)	1.22 (4.0)	1.07 (3.5)
80 (3)	2.44 (8.0)	2.44 (8.0)	2.29 (7.5)	2.13 (7.0)	1.37 (4.5)	1.22 (4.0)
100 (4)	2.59 (8.5)	2.59 (8.5)	2.59 (8.5)	2.29 (7.5)	1.52 (5.0)	1.37 (4.5)
150 (6)	3.05 (10.0)	2.90 (9.5)	2.74 (9.0)	2.44 (8.0)	1.68 (5.5)	1.52 (5.0)
200 (8)	3.35 (11.0)	3.20 (10.5)	3.05 (10.0)	2.74 (9.0)	1.83 (6.0)	1.68 (5.5)
250 (10)	3.51 (11.5)	3.35 (11.0)	3.20 (10.5)	2.90 (9.5)	1.98 (6.5)	1.83 (6.0)
300 (12)	3.81 (12.5)	3.66 (12.0)	3.51 (11.5)	3.20 (10.5)	2.29 (7.5)	1.98 (6.5)

Note: The above spacing values are based on test data developed by the manufacturer for the specific product and continuous spans. The piping is insulated and is full of liquid that has a specific gravity of 1.0.
Source: Harvel Plastics, Product Bulletin 112/401 (rev. 10/1/95), p. 63.

Table 5-7 Bedding Factor, K_v	
Type of Installation	K_v
Shaped bottom with tamped backfill material placed at the sides of the pipe, 95% Proctor density or greater	0.083
Compacted coarse-grained bedding and backfill material placed at the side of the pipe, 70-100% relative density	0.083
Shaped bottom, moderately compacted backfill material placed at the sides of the pipe, 85-95% Proctor density	0.103
Coarse-grained bedding, lightly compacted backfill material placed at the sides of the pipe, 40-70% relative density	0.103
Flat bottom, loose material placed at the sides of the pipe (not recommended); <35% Proctor density, <40% relative density	0.110

Source: Reprinted from Schweitzer, *Corrosion-Resistant Piping Systems*, p. 49, by courtesy of Marcel Dekker, Inc.

Table 5-8 Deflection Lag Factor, d_e	
Installation Condition	d_e
Burial depth <5 ft. with moderate to high degree of compaction (85% or greater Proctor, ASTM D 698 or 50% or greater relative density ASTM D-2049)	2.0
Burial depth <5 ft. with dumped or slight degree of compaction (Proctor > 85%, relative density > 40%)	1.5
Burial depth >5 ft. with moderate to high degree of compaction	1.5
Burial depth > 5 ft. with dumped or slight degree of compaction	1.25
Source: Reprinted from Schweitzer, <i>Corrosion-Resistant Piping Systems</i> , p. 49, by courtesy of Marcel Dekker, Inc.	

Table 5-9 Values of E' Modulus of Soil Reaction for Various Soils				
Soil Type and Pipe Bedding Material	E' for Degree of Compaction of Bedding, MPa (lb/ft ²)			
	Dumped	Slight <85% Proctor >40% rel. den.	Moderate 85-95% Proctor 40-70% rel. den.	High >90% Proctor >70% rel. den.
Fine-grained soils (LL >50) with medium to high plasticity CH, MH, CH-MH	No data available - consult a soil engineer or use $E' = 0$			
Fine-grained soils (LL <50) with medium to no plasticity CL, ML, ML-CL, with <25% coarse-grained particles	0.35 (50)	1.38 (200)	2.76 (400)	6.90 (1000)
Fine-grained soils (LL <50) with no plasticity CL, ML, ML-CL, with >25% coarse-grained particles.	0.69 (100)	2.76 (400)	6.90 (1000)	13.8 (2000)
Coarse-grained soils with fines GM, GC, SM, SC contains >12% fines.	0.69 (100)	2.76 (400)	6.90 (1000)	13.8 (2000)
Coarse-grained soils with little or no fines GW, SW, GP, SP contains <12% fines (or any borderline soil beginning with GM-GC or GC-SC)	1.38 (200)	6.90 (1000)	13.8 (2000)	20.7 (3000)
Crushed rock	6.90 (1000)	20.7 (3000)	20.7 (3000)	20.7 (3000)
Notes: LL = liquid limit Sources: AWWA C900, Table A.4., p.17. Schweitzer, <i>Corrosion-Resistant Piping Systems</i> , p. 48, (by courtesy of Marcel Dekker, Inc.).				

foot below the frost line. The trench bottom should be relatively flat, and smooth, with no sharp rocks that could damage the pipe material. The pipe should be bedded with a uniformly graded material that will protect the pipe during backfill. Typical installations use an American Association of State Highway Transportation Officials (AASHTO) #8 aggregate, or pea-gravel for six inches below and above the pipe. These materials can be dumped in the trench at approximately 90-95% Proctor without mechanical compaction. The remainder of the trench should be backfilled with earth, or other material appropriate for surface construction, and compacted according to the design specifications.

5-2. Polyvinyl Chloride (PVC)

Polyvinyl chloride (PVC) is the most widely used thermoplastic piping system. PVC is stronger and more rigid than the other thermoplastic materials. When specifying PVC thermoplastic piping systems particular attention must be paid to the high coefficient of expansion-contraction for these materials in addition to effects of temperature extremes on pressure rating, viscoelasticity, tensile creep, ductility, and brittleness.

a. PVC Specifications

PVC pipe is available in sizes ranging from 8 to 400 mm (1/4 to 16 in), in Schedules 40 and 80. Piping shall conform to ASTM D 2464 for Schedule 80 threaded type; ASTM D 2466 for Schedule 40 socket type; or ASTM D 2467 for Schedule 80 socket type.

Maximum allowable pressure ratings decrease with increasing diameter size. To maintain pressure ratings at standard temperatures, PVC is also available in Standard Dimension Ratio (SDR). SDR changes the dimensions of the piping in order to maintain the maximum allowable pressure rating.

b. PVC Installation

For piping larger than 100 mm (4 in) in diameter, threaded fittings should not be used. Instead socket welded or flanged fittings should be specified. If a threaded PVC piping system is used, two choices are available, either use all Schedule 80 piping and fittings, or use Schedule 40 pipe and Schedule 80 threaded fittings. Schedule 40 pipe will not be threaded. Schedule 80 pipe would be specified typically for larger diameter

pipes, elevated temperatures, or longer support span spacing. The system is selected based upon the application and design calculations.

The ranking of PVC piping systems from highest to lowest maximum operating pressure is as follows: Schedule 80 pipe socket-welded; Schedule 40 pipe with Schedule 80 fittings, socket-welded; and Schedule 80 pipe threaded. Schedule 40 pipe provides equal pressure rating to threaded Schedule 80, making Schedule 80 threaded uneconomical. In addition, the maximum allowable working pressure of PVC valves is lower than a Schedule 80 threaded piping system.

5-3. Polytetrafluoroethylene (PTFE)

Polytetrafluoroethylene (PTFE) is a very common thermoplastic material used in many other applications in addition to piping systems. PTFE is chemically resistant and has a relatively wide allowable temperature range of -260°C (-436°F) to 260°C (500°F). Furthermore, PTFE has a high impact resistance and a low coefficient of friction and is often considered “self-lubricating.” The most common trade name for PTFE is Teflon, registered trademark of E.I. DuPont Company.

5-4. Acrylonitrile-Butadiene-Styrene (ABS)

Acrylonitrile-Butadiene-Styrene (ABS) is a thermoplastic material made with virgin ABS compounds meeting the ASTM requirements of Cell Classification 4-2-2-2-2 (pipe) and 3-2-2-2-2 (fittings). Pipe is available in both solid wall and cellular core wall, which can be used interchangeably. Pipe and fittings are available in size 32 mm (1-1/4 in) through 300 mm (12 in) in diameter. The pipe can be installed above or below grade.

a. ABS Standards

ASTM D 2282 specifies requirements for solid wall ABS pipe. ASTM D 2661 specifies requirements for solid wall pipe for drain, waste, and vents. ASTM F 628 specifies requirements for drain, waste, and vent pipe and fittings with a cellular core. Solid wall ABS fittings conform to ASTM D 2661. The drainage pattern for fittings is specified by ASTM D 3311.

ABS compounds have many different formulations that vary by manufacturer. The properties of the different formulations also vary extensively. ABS shall be

specified very carefully and thoroughly because the acceptable use of one compound does not mean that all ABS piping systems are acceptable. Similarly, ABS compositions that are designed for air or gas handling may not be acceptable for liquids handling.

b. ABS Limitations

Pigments are added to the ABS to make pipe and fittings resistant to ultraviolet (UV) radiation degradation. Pipe and fittings specified for buried installations may be exposed to sunlight during construction, however, and prolonged exposure is not advised.

ABS pipe and fittings are combustible materials; however, they may be installed in noncombustible buildings. Most building codes have determined that ABS must be protected at penetrations of walls, floors, ceilings, and fire resistance rated assemblies. The method of protecting the pipe penetration is using a through-penetration protection assembly that has been tested and rated in accordance with ASTM E 814. The important rating is the "F" rating for the through penetration protection assembly. The "F" rating must be a minimum of the hourly rating of the fire resistance rated assembly that the ABS plastic pipe penetrates. Local code interpretations related to through penetrations are verified with the jurisdiction having authority.

5-5. Chlorinated Polyvinyl Chloride (CPVC)

Chlorinated polyvinyl chloride (CPVC) is more highly chlorinated than PVC. CPVC is commonly used for chemical or corrosive services and hot water above 60°C (140°F) and up to 99°C (210°F). CPVC is commercially available in sizes of 8 to 300 mm (1/4 to 12 in) for Schedule 40 and Schedule 80. Exposed CPVC piping should not be pneumatically tested, at any pressure, due to the possibility of personal injury from fragments in the event of pipe failure; see Paragraph 3-8d for further information.

ASTM specifications for CPVC include: ASTM F 437 for Schedule 80 threaded type; ASTM F 439 for Schedule 80 socket type; and ASTM F 438 for Schedule

40 socket type. However, note that Schedule 40 socket may be difficult to procure.

5-6. Polyethylene (PE)

Polyethylene (PE) piping material properties vary as a result of manufacturing processes. Table 5-10 lists the common types of PE, although an ultra high molecular weight type also exists. PE should be protected from ultraviolet radiation by the addition of carbon black as a stabilizer; other types of stabilizers do not protect adequately⁴. PE piping systems are available in sizes ranging from 15 to 750 mm (½ to 30 in). Like PVC, PE piping is available in SDR dimensions to maintain maximum allowable pressure ratings.

5-7. Polypropylene (PP)

Polypropylene (PP) piping materials are similar to PE, containing no chlorine or fluorine. PP piping systems are available in Schedule 40, Schedule 80, and SDR dimensions. With a specific gravity of 0.91, PP piping systems are one of the lightest thermoplastic piping systems.

5-8. Polyvinylidene Fluoride (PVDF)

Polyvinylidene fluoride (PVDF) pipe is available in a diameter range of 15 to 150 mm (½ to 6 in); Schedules 40 and 80; and pressure ratings of 1.03 MPa (150 psig) and 1.59 MPa (230 psig). Use of PVDF with liquids above 49°C (120°F) requires continuous support. Care must be taken in using PVDF piping under suction. PVDF does not degrade in sunlight; therefore, PVDF does not require UV stabilizers or antioxidants. PVDF pipe is chemically resistant to most acids; bases and organics; and can transport liquid or powdered halogens such as chlorine or bromine. PVDF should not be used with strong alkalis, fuming acids, polar solvents, amines, ketones or esters⁵. Trade names for PVDF pipe include Kynar by Elf Atochem, Solef by Solvay, Hylar by Ausimont USA, and Super Pro 230 by Asahi America.

Fusion welding is the preferred method for joining PVDF pipe. Threading can only be accomplished on Schedule 80 pipe.

⁴ Schweitzer, *Corrosion-Resistant Piping System*, p. 39.

⁵ *Ibid.*, p. 43.

Table 5-10 Polyethylene Designations		
Type	Standard	Specific Gravity
Low Density (LDPE)	ASTM D 3350, Type I	0.91 to 0.925
Medium Density (MDPE)	ASTM D 3350, Type II	0.926 to 0.940
High Density (HDPE)	ASTM D 3350, Type III and ASTM D 1248 Type IV	0.941 to 0.959

Source: Compiled by SAIC, 1998

Chapter 6 Rubber and Elastomer Piping Systems

6-1. General

The diverse nature of the chemical and physical characteristics of rubber and elastomeric materials makes these materials suited for many chemical handling and waste treatment applications. The most common elastomeric piping systems are comprised of hoses. These hoses are constructed of three components: the tube, the reinforcement, and the cover. The tube is most commonly an elastomer and must be suitable for the chemical, temperature, and pressure conditions that a particular application involves. Table 6-1 lists several elastomers used in piping systems and the chemical identifications of the polymers. Physical and chemical characteristics of elastomers used in hose manufacturing are specified in ASTM D 2000. Hose reinforcement is designed to provide protection from internal forces, external forces, or both. Reinforcement usually consists of a layer of textile, plastic, metal, or a combination of these materials. Hose covers are designed to provide hoses with protection from negative impacts resulting from the environment in which the hose is used. Covers are also typically composed of textile, plastic, metal, or a combination of these materials.

6-2. Design Factors

In selecting and sizing a rubber or elastomeric piping system, four factors must be considered: service conditions, (pressure and temperature); operating conditions (indoor/outdoor use, vibration resistance, intermittent or continuous service, etc.); end connections; and environment requirements (flame resistance, material conductivity, labeling requirements, etc.).

a. Service Conditions

For applications requiring pressure or vacuum service reinforcement can improve the mechanical properties of the hose. The maximum recommended operating pressure in industrial applications utilizing Society of Automotive Engineers (SAE) standards hose designations is approximately 25% of the rated bursting pressure of the specific hose. Table 6-2 lists common SAE hose standards.

In determining the maximum operating conditions, special consideration must be given to the operating temperatures. Rubber and elastomer materials are temperature sensitive, and both the mechanical qualities and chemical resistance properties of the materials are affected by temperature. Appendix B provides information regarding the effects of temperature on chemical resistance, and Table 6-1 provides information

**Table 6-1
Common Materials Used in Rubber/Elastomer Piping Systems**

Elastomer	ASTM D 1418 Class	Common or Trade Name	Minimum Service Temperature - Continuous Operations	Maximum Service Temperature - Continuous Operations
Fluoroelastomer	FKM	FKM, Viton, Fluorel	-23°C (-10°F)	260°C (500°F)
Isobutylene Isoprene	IIR	Butyl	-46°C (-50°F)	148°C (300°F)
Acrylonitrile Butadiene	NBR	Buna-N, Nitrile	-51°C (-60°F)	148°C (300°F)
Polychloroprene	CR	Neoprene	-40°C (-40°F)	115°C (240°F)
Natural Rubber or Styrene Butadiene	NR or SBR	Gum Rubber; Buna-S	-51°C (-60°F)	82°C (180°F)

Source: Compiled by SAIC, 1998.

Table 6-2 Rubber and Elastomer Hose Standards			
SAE Designation	Tube	Reinforcement	Cover
100R1A		one-wire-braid	synthetic-rubber
100RIT		one-wire-braid	thin, nonskive
100R2A		two-wire-braid	synthetic rubber
100R2B		two spiral wire plus one wire-braid	synthetic rubber
100R2AT		two-wire-braid	thin, nonskive
100R2BT		two spiral wire plus one wire-braid	thin, nonskive
100R3		two rayon-braided	synthetic rubber
100R5		one textile braid plus one wire-braid	textile braid
100R7	thermoplastic	synthetic-fiber	thermoplastic
100R8	thermoplastic	synthetic-fiber	thermoplastic
100R9		four-ply, light-spiral-wire	synthetic-rubber
100R9T		four-ply, light-spiral-wire	thin, nonskive

Source: Compiled by SAIC, 1998.

on the temperature limitations of the mechanical properties of rubber and elastomeric materials. As the operating temperature increases, the use of jacketed or reinforced hose should be considered to accommodate the lower pressure ratings of the elastomeric materials.

Like plastic piping systems, rubber and elastomer systems do not display corrosion rates, as corrosion is totally dependent on the material's resistance to environmental factors rather than on the formation of an oxide layer. The corrosion of rubbers and elastomers is indicated by material softening, discoloring, charring, embrittlement, stress cracking (also referred to as crazing), blistering, swelling, and dissolving. Corrosion of rubber and elastomers occurs through one or more of the following mechanisms: absorption, solvation, chemical reactions, thermal degradation, and environmental stress cracking.

General compatibility information for common elastomer is listed in Table 6-3. Information regarding the compatibility of various elastomers with specific chemicals can be found in Appendix B. In addition, standards for resistance to oil and gasoline exposure have been developed by the Rubber Manufacturer's Association (RMA). These standards are related to the effects of oil or gasoline exposure for 70 hours at 100 °C (ASTM D 471) on the physical/mechanical properties of the material. Table 6-4 summarizes the requirements of the RMA oil and gasoline resistance classes.

b. Operating Conditions

In most cases, the flexible nature of elastomers will compensate for vibration and thermal expansion and contraction in extreme cases. However, designs should incorporate a sufficient length of hose to compensate for the mechanical effects of vibration and temperature.

**Table 6-3
General Chemical Compatibility Characteristics of Common Elastomers**

Material	Good Resistance	Poor Resistance
Fluoroelastomer	Oxidizing acids and oxidizers, fuels containing <30% aromatics	Aromatics; fuels containing >30% aromatics
Isobutylene Isoprene	Dilute mineral acids, alkalis, some concentrated acids, oxygenated solvents	Hydrocarbons and oils, most solvents, concentrated nitric and sulfuric acids
Acrylonitrile Butadiene	Oils, water, and solvents	Strong oxidizing agents, polar solvents, chlorinated hydrocarbons
Polychloroprene	Aliphatic solvents, dilute mineral acids, salts, alkalis	Strong oxidizing acids, chlorinated and aromatic hydrocarbons
Natural Rubber or Styrene Butadiene	Non-oxidizing acids, alkalis, and salts	Hydrocarbons, oils, and oxidizing agents
Notes: See Appendix B for more chemical resistance information. Source: Compiled by SAIC, 1998.		

**Table 6-4
RMA Oil and Gasoline Resistance Classifications**

RMA Designation	Maximum Volume Change	Tensile Strength Retained
Class A (High oil resistance)	+25%	80%
Class B (Medium-High oil resistance)	+65%	50%
Class C (Medium oil resistance)	+100%	40%
Source: RMA, "The 1996 Hose Handbook," IP-2, p. 52.		

c. End Connections

Hose couplings are used to connect hoses to a process discharge or input point. Methods for joining elastomeric hose include banding/clamping, flanged joints, and threaded and mechanical coupling systems. These methods are typically divided into reusable and non-reusable couplings. Table 6-5 lists common types of couplings for hoses. Selection of the proper coupling should take into account the operating conditions and procedures that will be employed.

d. Environmental Requirements

Hose is also manufactured with conductive, non-conductive, and uncontrolled electrical properties. Critical applications such as transferring aircraft hose or transferring liquids around high-voltage lines, require the electrical properties of hose to be controlled. Unless the

hose is designated as conducting or nonconducting, the electrical properties are uncontrolled. Standards do not currently exist for the prevention and safe dissipation of static charge from hoses. Methods used to control electrical properties include designing contact between a body reinforcing wire and a metal coupling to provide electrical continuity for the hose or using a conductive hose cover. ASTM D 380 describes standard test methods for the conductivity of elastomeric hoses. For a hose to be considered non-conductive, it should be tested using these methods.

6-3. Sizing

The primary considerations in determining the minimum acceptable diameter of any elastomeric hose are design flow rate and pressure drop. The design flow rate is based on system demands that are normally established in the process design phase of a project and which should be

**Table 6-5
Typical Hose Couplings**

Class	Description
Reusable with clamps	<ol style="list-style-type: none"> 1. Short Shank Coupling 2. Long Shank Coupling 3. Interlocking Type 4. Compression Ring Type
Reusable without clamps	<ol style="list-style-type: none"> 1. Screw Type 2. Push-on Type
Non-reusable couplings	<ol style="list-style-type: none"> 1. Swaged-on 2. Crimped-on 3. Internally Expanded Full Flow Type 4. Built-in Fittings
Specialty couplings	<ol style="list-style-type: none"> 1. Sand Blast Sleeves 2. Radiator and Heater Clamps 3. Gasoline Pump Hose Couplings 4. Coaxial Gasoline Pump Couplings 5. Welding Hose Couplings 6. Fire Hose Couplings
Source: Compiled by SAIC, 1998.	

fully defined by this stage of the system design. Pressure drop through the elastomeric hose must be designed to provide an optimum balance between installed costs and operating costs. Primary factors that will impact these costs and system operating performance are internal diameter (and the resulting fluid velocity), materials of construction and length of hose.

6-4. Piping Support and Burial

Support for rubber and elastomer piping systems should follow similar principles as metallic and plastic pipe. However, continuous piping support is recommended for most applications due to the flexible nature of these materials. Also due to its flexible nature, elastomer piping is not used in buried service because the piping is unable to support the loads required for buried service.

When routing elastomer hose, change in piping direction can be achieved through bending the hose rather than using fittings. When designing a rubber or elastomer piping system, it is important to make sure that the bend radius used does not exceed the maximum bend radius for the hose used. If the maximum bend radius is exceeded, the hose may collapse and constricted flow or material failure could occur. As a rule of thumb, the bend radius should be six times the diameter of a hard wall hose or twelve times the diameter of a soft wall hose.

6-5. Fluoroelastomer

Fluoroelastomer (FKM) is a class of materials which includes several fluoropolymers used for hose products. Trade names of these materials include Viton and Fluorel. Fluoroelastomers provide excellent high temperature resistance, with the maximum allowable operating temperatures for fluoroelastomer varying from 232 to 315°C (450 to 600°F), depending upon the manufacturer. Fluoroelastomers also provide very good chemical resistance to a wide variety of chemical classes.

6-6. Isobutylene Isoprene

Isobutylene isoprene (Butyl or IIR) has excellent abrasion resistance and excellent flexing properties. These characteristics combine to give isobutylene isoprene very good weathering and aging resistance. Isobutylene isoprene is impermeable to most gases, but provides poor resistance to petroleum based fluids. Isobutylene isoprene is also not flame resistant.

6-7. Acrylonitrile Butadiene

Acrylonitrile butadiene (nitrile, Buna-N or NBR) offers excellent resistance to petroleum oils, aromatic hydrocarbons and many acids. NBR also has good elongation properties. However, NBR does not provide good resistance to weathering.

6-8. Polychloroprene

Polychloroprene (neoprene or CR) is one of the oldest synthetic rubbers. It is a good all-purpose elastomer that is resistant to ozone, ultraviolet radiation, and oxidation. Neoprene is also heat and flame resistant. These characteristics give neoprene excellent resistance to aging and weathering. Neoprene also provides good chemical resistance to many petroleum based products and aliphatic hydrocarbons. However, neoprene is vulnerable to chlorinated solvents, polar solvents, and strong mineral acids.

6-9. Natural Rubber

Natural rubber (styrene butadiene, gum rubber, Buna-S, NR, or SBR) has high resilience, good tear resistance, and good tensile strength. It also exhibits wear resistance and is flexible at low temperatures. These characteristics make natural rubber suitable for general service outdoor use. However, natural rubber is not flame resistant and does not provide resistance to petroleum based fluids.

Chapter 7 Thermoset Piping Systems

7-1. General

Thermoset piping systems are composed of plastic materials and are identified by being permanently set, cured or hardened into shape during the manufacturing process. Thermoset piping system materials are a combination of resins and reinforcing. The four primary thermoset resins are epoxies, vinyl esters, polyesters, and furans. Other resins are available.

a. Thermoset Piping Characteristics

Advantages of thermoset piping systems are a high strength-to-weight ratio; low installation costs; ease of repair and maintenance; hydraulic smoothness with a typical surface roughness of 0.005 mm (0.0002 in); flexibility, since low axial modulus of elasticity allows lightweight restraints and reduces the need for expansion loops; and low thermal and electrical conductivity. Disadvantages of thermoset piping systems are low temperature limits; vulnerability to impact failure; increased support requirements, a drawback of the low modulus of elasticity; lack of dimensional standards including joints since pipe, fittings, joints and adhesives are generally not interchangeable between manufacturers; and susceptibility to movement with pressure surges, such as water hammer. Table 7-1 lists applicable standards for thermoset piping systems.

b. Corrosion Resistance

Like other plastic materials, thermoset piping systems provide both internal and external corrosion resistance. For compatibility of thermoset plastic material with various chemicals, see Appendix B. Due to the different formulations of the resin groups, manufacturers are contacted to confirm material compatibility. For applications that have limited data relating liquid services and resins, ASTM C 581 provides a procedure to evaluate the chemical resistance of thermosetting resins.

c. Materials of Construction

Fiberglass is the most common reinforcing material used in thermoset piping systems because of its low cost, high tensile strength, light weight and good corrosion

resistance. Other types of commercially available reinforcement include graphite fibers for use with fluorinated chemicals such as hydrofluoric acid; aramid; polyester; and polyethylene. The types of fiberglass used are E-glass; S-glass for higher temperature and tensile strength requirements; and C-glass for extremely corrosive applications.

Most thermoset piping systems are manufactured using a filament winding process for adding reinforcement. This process accurately orients and uniformly places tension on the reinforcing fibers for use in pressure applications. It also provides the best strength-to-weight ratio as compared to other production methods. The other main method of manufacturing is centrifugal casting, particularly using the more reactive resins.

Thermoset piping can be provided with a resin-rich layer (liner) to protect the reinforcing fibers. The use of liners is recommended for chemical and corrosive applications. Liners for filament wound pipe generally range in thickness from 0.25 to 1.25 mm (0.01 to 0.05 in), but can be custom fabricated as thick as 2.8 mm (0.110 in) and are often reinforced. Liner thickness for centrifugally cast thermoset piping generally ranges from 1.25 to 2.0 mm (0.05 to 0.08 in); these liners are not reinforced. If not reinforced, liners may become brittle when exposed to low temperatures. Impacts or harsh abrasion may cause failure under these conditions.

Fittings are manufactured using compression molding, filament winding, spray-up, contact molding and mitered processes. Compression molding is typically used for smaller diameter fittings, and filament winding is used for larger, 200 to 400 mm (8 to 16 in), fittings. The spray-up, contact molding and mitered processes are used for complex or custom fittings. The mitered process is typically used for on-site modifications.

d. Operating Pressures and Temperatures

Loads; service conditions; materials; design codes and standards; and system operational pressures and temperatures are established as described in Chapters 2 and 3 for plastic piping systems. Table 7-2 lists recommended temperature limits for reinforced thermosetting resin pipe.

Table 7-1
Thermoset Piping Systems Standards (As of Nov. 1997)

Standard	Application
ASTM D 2310	Machine-made reinforced thermosetting pipe.
ASTM D 2996	Filament wound fiberglass reinforced thermoset pipe.
ASTM D 2997	Centrifugally cast reinforced thermoset pipe.
ASTM D 3517	Fiberglass reinforced thermoset pipe conveying water.
ASTM D 3754	Fiberglass reinforced thermoset pipe conveying industrial process liquids and wastes.
ASTM D 4024	Reinforced thermoset flanges.
ASTM D 4161	Fiberglass reinforced thermoset pipe joints using elastomeric seals.
ASTM F 1173	Epoxy thermoset pipe conveying seawater and chemicals in a marine environment.
AWWA C950	Fiberglass reinforced thermoset pipe conveying water.
API 15LR	Low pressure fiberglass reinforced thermoset pipe.

Source: Compiled by SAIC, 1998.

Table 7-2
Recommended Temperature Limits for Reinforced Thermosetting Resin Pipe

Materials		Recommended Temperature Limits			
Resin	Reinforcing	Minimum		Maximum	
		°F	°C	°F	°C
Epoxy	Glass Fiber	-20	-29	300	149
Furan	Carbon	-20	-29	200	93
Furan	Glass Fiber	-20	-29	200	93
Phenolic	Glass Fiber	-20	-29	300	149
Polyester	Glass Fiber	-20	-29	200	93
Vinyl Ester	Glass Fiber	-20	-29	200	93

Source: ASME B31.3, p. 96, Reprinted by permission of ASME.

e. Thermoset Piping Support

Support for thermoset piping systems follow similar principles as thermoplastic piping systems. Physical properties of the materials are similar enough that the same general recommendations apply. Spacing of supports is crucial to the structural integrity of the piping system. Valves, meters, and other miscellaneous fittings are supported independently of pipe sections. Separate supports are provided on either side of flanged connections. Additionally, anchor points, such as where the pipeline changes direction, are built-up with a rubber

sleeve at least the thickness of the pipe wall. This provides protection for the pipe material on either side of the anchor.

Reinforced polyester pipe requires a wide support surface on the hanger. It also calls for a rubber or elastomeric cushion between the hanger and the pipe to isolate the pipe from point loads. This cushion is approximately 3 mm (1/8 in) thick. Table 7-3 summarizes the maximum support spacing at various system pressures for reinforced epoxy pipe.

Table 7-3 Support Spacing for Reinforced Epoxy Pipe						
Nominal Pipe Size, mm (in)	Maximum Support Spacing, m (ft) at Various Temperatures					
	24°C (75°F)	66°C (150°F)	79°C (175°F)	93°C (200°F)	107°C (225°F)	121°C (250°F)
25 (1)	3.20 (9.9)	2.99 (9.8)	2.96 (9.7)	2.87 (9.4)	2.83 (9.3)	2.65 (8.7)
40 (1.5)	3.54 (11.6)	3.47 (11.4)	3.44 (11.3)	3.35 (11.0)	3.29 (10.8)	3.08 (10.1)
50 (2)	3.99 (13.1)	3.93 (12.9)	3.90 (12.8)	3.78 (12.4)	3.72 (12.2)	3.47 (11.4)
80 (3)	4.57 (15.0)	4.51 (14.8)	4.45 (14.6)	4.33 (14.2)	4.27 (14.0)	3.96 (13.0)
100 (4)	5.09 (16.7)	5.03 (16.5)	4.97 (16.3)	4.82 (15.8)	4.75 (15.6)	4.42 (14.5)
150 (6)	5.76 (18.9)	5.67 (18.6)	5.61 (18.4)	5.46 (17.9)	5.36 (17.6)	5.00 (16.4)
200 (8)	6.10 (20.0)	6.10 (20.0)	6.04 (19.8)	5.88 (19.3)	5.79 (19.0)	5.39 (17.7)
250 (10)	6.10 (20.0)	6.10 (20.0)	6.10 (20.0)	6.10 (20.0)	6.10 (20.0)	5.73 (18.8)
300 (12)	6.10 (20.0)	6.10 (20.0)	6.10 (20.0)	6.10 (20.0)	6.10 (20.0)	6.00 (19.7)
350 (14)	6.10 (20.0)	6.10 (20.0)	6.10 (20.0)	6.10 (20.0)	6.10 (20.0)	6.10 (20.0)

Note: The above spacing values are based on long-term elevated temperature test data developed by the manufacturer for the specific product. The above spacing is based on a 3-span continuous beam with maximum rated pressure and 12.7 mm (0.5 in) deflection. The piping is assumed to be centrifugally cast and is full of liquid that has a specific gravity of 1.00.

Source: Fibercast, Centricast Plus RB-2530, p. 2.

The same principles for pipe support for reinforced polyester apply to reinforced vinyl ester and reinforced epoxy thermoset pipe. Span distances for supports vary from manufacturer to manufacturer. The design of piping systems utilizing reinforced vinyl ester or reinforced epoxy pipe reference the manufacturer's recommendations for support spacing.

Each section of thermoset piping has at least one support. Additionally, valves, meters, flanges, expansion joints, and other miscellaneous fittings are supported independently. Supports are not attached to flanges or expansion joints. Supports allow axial movement of the pipe.

f. Thermoset Piping Burial

Reinforced polyester, vinyl ester, and epoxy pipe may be buried. The same basic principles which apply to burying plastic pipe also apply for thermoset pipe regarding frost line, trench excavation, pipe installation, and backfill. For operating pressures greater than 689 kPa (100 psi), the internal pressure determines the required wall thickness. For operating pressures less than 689 kPa (100 psi), the vertical pressure on the pipe from ground cover and wheel load dictates the required wall thickness of the pipe.

g. Joining

Common methods for the joining of thermoset pipe for liquid process waste treatment and storage systems include the use of adhesive bonded joints, over wrapped joints, and mechanical joining systems. The application requirements and material specification for these fittings are found in various codes, standards, and manufacturer procedures and specifications, including:

- ASME B31.3 Chapter VII;
- ASME B31.1 Power Piping Code;
- The Piping Handbook, 6th Edition; and
- Fibercast Company Piping Design Manual.

h. Thermal Expansion

When designing a piping system in which thermal expansion of the piping is restrained at supports, anchors, equipment nozzles, and penetrations, thermal stresses and

loads must be analyzed and accounted for within the design. The system PFDs and P&IDs are analyzed to determine the thermal conditions or modes to which the piping system will be subjected during operation. Based on this analysis, the design and material specification requirements are determined from an applicable standard or design reference.

The primary objective of the analysis is to identify operating conditions that will expose the piping to the most severe thermal loading conditions. Once these conditions have been established, a free or unrestrained thermal analysis of the piping can be performed to establish location, sizing, and arrangement of expansion joints or loops. Due to the cost of thermoset piping, the use of loops is not normally cost-effective.

The following procedure can be used to design expansion joints in fiberglass piping systems. The expansion joint must be selected and installed to accommodate the maximum axial motion in both expansion and contraction. This typically requires that some amount of preset compression be provided in the expansion joint to accommodate for all operating conditions. In addition, suitable anchors must be provided to restrain the expansion joint; guides must be installed to assure that the pipe will move directly into the expansion joint in accordance with manufacturer requirements; and pipe supports, which allow axial movement, prevent lateral movement, and provide sufficient support to prevent buckling, must be included in the design.

Step 1: Determine Required Preset

$$Length\ of\ Preset = \frac{R(T_i - T_{min})}{T_{max} - T_{min}}$$

where:

- R = rated movement of expansion joint, mm (in)
- T_i = installation temperature, °C (°F)
- T_{min} = minimum system temperature, °C (°F)
- T_{max} = maximum system temperature, °C (°F)

Step 2: Design expansion loops using the equation provided in Paragraph 4-6, or consult with the piping manufacturer; for example, see Table 7-4.

Table 7-4
Loop Leg Sizing Chart for Fibercast RB-2530 Pipe

D _o mm (in)	Thermal Expansion, mm (in), versus Minimum Leg Length, m (ft)					
	25.4 mm (1 in)	50.8 mm (2 in)	76.2 mm (3 in)	127 mm (5 in)	178 mm (7 in)	229 mm (9 in)
33.40 (1.315)	1.22 m (4 ft)	1.52 m (5 ft)	1.83 m (6 ft)	2.44 m (8 ft)	2.74 m (9 ft)	3.05 m (10 ft)
48.26 (1.900)	1.83 m (6 ft)	2.44 m (8 ft)	2.74 m (9 ft)	3.66 m (12 ft)	4.27 m (14 ft)	4.88 m (16 ft)
60.33 (2.375)	2.13 m (7 ft)	3.05 m (10 ft)	3.66 m (12 ft)	4.88 m (16 ft)	5.79 m (19 ft)	6.40 m (21 ft)
88.90 (3.500)	2.74 m (9 ft)	3.96 m (13 ft)	4.88 m (16 ft)	6.10 m (20 ft)	7.32 m (24 ft)	8.23 m (27 ft)
114.3 (4.500)	3.66 m (12 ft)	4.88 m (16 ft)	6.10 m (20 ft)	7.62 m (25 ft)	9.14 m (30 ft)	10.4 m (34 ft)
168.3 (6.625)	4.57 m (15 ft)	6.40 m (21 ft)	7.62 m (25 ft)	9.75 m (32 ft)	11.6 m (38 ft)	13.1 m (43 ft)
219.1 (8.625)	5.18 m (17 ft)	7.01 m (23 ft)	8.84 m (29 ft)	11.3 m (37 ft)	13.1 m (43 ft)	14.9 m (49 ft)
273.1 (10.75)	5.79 m (19 ft)	7.92 m (26 ft)	9.75 m (32 ft)	12.5 m (41 ft)	14.6 m (48 ft)	16.8 m (55 ft)
323.9 (12.75)	6.10 m (20 ft)	8.53 m (28 ft)	10.4 m (34 ft)	13.4 m (44 ft)	15.8 m (52 ft)	18.0 m (59 ft)
355.6 (14.00)	5.79 m (19 ft)	7.92 m (26 ft)	9.75 m (32 ft)	12.5 m (41 ft)	14.9 m (49 ft)	16.8 m (55 ft)

Notes: D_o = outside diameter of standard Fibercast pipe. D_o may be different for other manufacturers.
Thermal expansion characteristics and required loop lengths will vary between manufacturers.
Source: Fibercast, Piping Design Manual, FC-680, p. 6.

7-2. Reinforced Epoxies

Although epoxies cure without the need for additional heat, almost all pipe is manufactured with heat-cure. Reinforced epoxy piping systems are not manufactured to dimensional or pressure standards. Therefore, considerable variation between manufacturers exist in regard to available size, maximum pressure rating and maximum temperature rating. Performance requirements, including manufacturing, conforms to ASTM standards in order to not sole-source the piping system.

7-3. Reinforced Polyesters

Reinforced polyester thermoset piping systems are the most widely used due to affordability and versatility. The maximum continuous operating temperature for optimum chemical resistance is 71°C (160°F). Like the epoxies, reinforced polyester piping systems are not manufactured to dimensional or pressure standards. Variation of available piping sizes, maximum pressure rating, and maximum temperature ratings exist between manufacturers. Performance requirements, including manufacturing, conform to ASTM standards in order to not sole-source the piping system.

¹ Schweitzer, *Corrosion-Resistant Piping Systems*, p. 102.

7-4. Reinforced Vinyl Esters

The vinyl ester generally used for chemical process piping systems is bisphenol-A fumarate due to good corrosion resistance¹. Reinforced vinyl ester piping systems vary by manufacturer for allowable pressures and temperatures. Performance requirements, including manufacturing, conforms to ASTM standards in order to not sole-source the piping system.

7-5. Reinforced Furans

The advantage of furan resins is their resistance to solvents in combination with acids or bases². Furans are difficult to work with and should not be used for oxidizing applications. Maximum operating temperatures for furan resins can be 189°C (300°F). Furan resin piping is commercially available in sizes ranging from 15 to 300 mm (½ to 12 in) standard.

² Schweitzer, Corrosion-Resistant Piping Systems, p. 96.

Chapter 8

Double Containment Piping Systems

8-1. General

To date, the double containment piping system design has not been standardized. If possible, the use of double containment piping should be deferred until design and construction standards are published by a national standards organization, such as ASTM. An alternative to the factory designed secondary containment piping may be the use of single wall piping inside a sealed, watertight, 360-degree secondary containment barrier; refer to CEGS 11145, Aviation Fueling Systems. Due to the nature of the liquids transported in double containment piping systems, the primary standard for the design of these systems is the ASME B31.3, Chemical Plant and Petroleum Refinery Piping Code.

a. Regulatory Basis

Secondary containment is a means by which to prevent and detect releases to the environment. Therefore, when dealing with regulated substances in underground storage tank systems or when managing hazardous wastes, regulations typically require secondary containment of piping systems for new construction. Double wall piping systems are available to provide secondary containment. The double containment piping system is composed of an outer pipe that completely encloses an inner carrier pipe in order to detect and contain any leaks that may occur and to allow detection of such leaks.

Under storage tank regulation 40 CFR 280, secondary containment is required for tanks containing hazardous substances (as defined by CERCLA 101-14) or petroleum products. The requirement applies whenever 10% or more of the volume of the tank is underground. Tank standards in hazardous waste regulations in 40 CFR 264 and 40 CFR 265 also require secondary containment of piping systems. These requirements are not only applicable to RCRA Part B permitted treatment storage and disposal facilities, but also apply to interim status facilities and to generators accumulating waste in tanks with ancillary piping.

b. Design Requirements

Many options seem to exist for the combination of

different primary (carrier) and secondary (containment) piping systems based on physical dimensions. However, the commercial availability of components must be carefully reviewed for the selected materials of construction. Availability of piping sizes, both diameter and wall thickness; joining methods; and pressure ratings may preclude the combination of certain primary and secondary piping system materials.

In addition, some manufacturers offer “pre-engineered” double containment piping systems. Some of these systems may have been conceptualized without detailed engineering of system components. If specified for use, the detailed engineering of the “pre-engineered” system must be performed, including any required customizing, details, and code review.

c. Material Selection

For piping system material compatibility with various chemicals, see Appendix B. Material compatibility should consider the type and concentration of chemicals in the liquid, liquid temperature, and total stress of the piping system. The selection of materials of construction should be made by an engineer experienced in corrosion or similar applications. See Appendix A, Paragraph A-4 - Other Sources of Information, for additional sources of corrosion data.

Corrosion of metallic and thermoplastic piping systems was addressed in Paragraphs 4-2 and 5-1. However, it must be remembered that cracking, such as stress-corrosion cracking and environmental stress cracking, is a potentially significant failure mechanism in double containment piping systems. Differential expansion of inner and outer piping can cause reaction loads at interconnecting components. These loads can produce tensile stresses that approach yield strengths and induce stress cracking at the interconnection areas.

Material combinations may be classified into three main categories:

- (1) the primary and secondary piping materials are identical except for size, for example, ASTM A 53 carbon steel and A 53 carbon steel, respectively;
- (2) the primary and secondary piping are the same type of materials but not identical, for example, 316L stainless steel and A 53 carbon steel; and
- (3) different types of materials are used, for example,

PVDF as primary and A 53 carbon steel as secondary. Table 8-1 provides a further breakdown and description of these three groups.

d. Thermal Expansion

As discussed in the previous chapters, when a piping system is subjected to a temperature change, it expands or contracts accordingly. Double containment piping systems have additional considerations, including expansion-contraction forces occurring between two potentially different, interconnected piping systems. Thermal stresses can be significant when flexibility is not taken into account in the design. For a double containment piping system, the primary and secondary piping systems must be analyzed both as individual systems and as parts of the whole. The basic correlations between the systems are: (1) the primary piping system has a greater temperature change; and (2) the secondary piping system has a greater temperature change.

Because of the insulating effect of the secondary piping system, the primary piping system usually only exhibits a larger temperature induced change when the process dictates, for example, when a hot liquid enters the piping system. In both above grade and buried systems, secondary piping system expansions are typically compensated for with expansion loops, changes in direction, or a totally restrained system. Expansion joints are not recommended for this use due to potential leaks, replacement and maintenance, unless they can be located in a tank or vault.

To accommodate the dimensional changes of the primary piping system in expansion loops and change of direction elbows, secondary piping systems are often increased in size. Another alternative is to fully restrain the primary piping system. Figure 8-1 demonstrates the result of differential movement between the piping systems without full restraint, and Figure 8-2 depicts an expansion loop with an increase to the secondary piping diameter.

Totally restrained systems are complex. Stresses are induced at points of interconnection, at interstitial supports, and at other areas of contact. For rigid piping systems, restraints are placed at the ends of straight pipe

lengths and before and after complex fittings to relieve thermal stress and prevent fitting failure¹. Plastic piping systems relieve themselves through deformation and wall relaxation, potentially leading to failure. Totally restrained systems should undergo a stress analysis and a flexibility analysis as part of the design.

The combined stress on the secondary piping system is the result of bending, as well as torsional, internal hydrostatic, and thermal expansion induced axial stresses. The following method, which assumes that internal hydrostatic and thermal expansion induced axial stresses approximate the total stress, can be used to determine whether a totally restrained design is suitable²:

$$S_c = \sqrt{(\sigma_{at})^2 + (\sigma_p)^2}$$

where:

- S_c = combined stress, MPa (psi)
- σ_{at} = thermal induced axial stress, MPa (psi)
- σ_p = internal hydrostatic stress, MPa (psi)

$$\sigma_{at} = E \alpha \Delta T$$

where:

- σ_{at} = thermal induced axial stress, MPa (psi)
- E = modulus of elasticity, MPa (psi)
- α = coefficient of thermal expansion, mm/mm/°C (in/in/°F)
- ΔT = differential between maximum operating and installation temperature, °C (°F)

$$\sigma_p = \frac{P (D_o - t)}{2 t}$$

where:

- σ_p = internal hydrostatic stress, MPa (psi)
- P = liquid pressure, MPa (psi)
- D_o = outside pipe diameter, mm (in)
- t = pipe wall thickness, mm (in)

¹ Schweitzer, *Corrosion-Resistant Piping Systems*, p. 417.

² *Ibid.*, pp. 418-420.

**Table 8-1
Double Containment Piping Material Combinations**

Category	Primary	Secondary	Comments	Common Materials
1	M	M	Used with elevated temperatures and/or pressures. Good structural strength and impact resistant. May be required by fire or building codes. Cathodic protection required if buried.	CS, 304 SS, 304L SS, 316 SS, 316L SS, 410 SS, Ni 200, Ni 201, Cu/Ni alloys
1	TS	TS	Common for above grade and buried use for organic, inorganic, and acid wastes/chemicals. Good chemical resistance and structural strength. Conductive to field fabrication.	polyester resin, epoxy resin, vinyl ester resin, furan resin
1	TP	TP	Easily joined and fabricated. Resistant to soil corrosion and many chemicals. May be restricted by fire/building codes. Impact safety may require safeguards.	PVC, CPVC, HDPE, PP, PVDF, ECTFE, ETFE, PFA
2	M	M	May be required by fire codes or mechanical properties. Galvanic actions must be controlled at crevices and interconnections. Cathodic protection required if buried.	CS-SS, Cu/Ni alloy - CS, CS-Ni, CS-410 SS
2	TS	TS	Not advisable to combine resin grades. Epoxy and polyester resins are most economical.	polyester-epoxy, vinyl ester-epoxy, vinyl ester-polyester
2	TP	TP	Common for above grade and buried acid/caustic use. Economical - many commercial systems are available.	Many - PVDF-PP, PVDF-HDPE, PP-HDPE
3	M	TS	Common and economical. Practical - interconnections have been developed. Good for buried use, may eliminate cathodic protection requirements.	epoxy-M (CS, SS, Ni, Cu), polyester-M (CS, SS, Ni, Cu)
3	M	TP	Common and economical. Good for buried use, may eliminate cathodic protection requirements. May be limited by fire or building codes.	HDPE - M (CS, SS), PVDF- M (CS, SS), PP-M (CS, SS)
3	M	O	Limited practical use except for concrete trench. Ability for leak detection is a concern.	concrete trench - M
3	TS	M	Common for above grade systems requiring thermoset chemical resistance and metallic mechanical properties. Can meet category "M" service per ASME code.	many
3	TS	TP	Economical. Good for buried applications.	epoxy-TP (HDPE, PVC, PP), polyester-TP (HDPE, PVC, PP)
3	TS	O	Limited practical use except for concrete trench. Ability for leak detection is a concern.	concrete trench - TS
3	TP	M	Common for above grade systems requiring thermoset chemical resistance and metallic mechanical properties. Can meet category "M" service per ASME code.	many
3	TP	TS	Limited in use - thermoplastic chemical resistance needed with thermoset mechanical properties. May not meet UL acceptance standards.	limited
3	TP	O	Limited practical use except for concrete trench or pipe. Ability for leak detection is a concern.	concrete trench - TP, concrete pipe - PVC
3	O	M	Interconnections may be difficult. Good for protection of brittle materials.	CS-glass, CS-clay

Notes: The primary piping material is listed first on primary-secondary combinations. Material designations are: M - metallic materials; TS - thermoset materials; TP - thermoplastic materials; and O - other nonmetallic materials
Source: Compiled by SAIC, 1998.

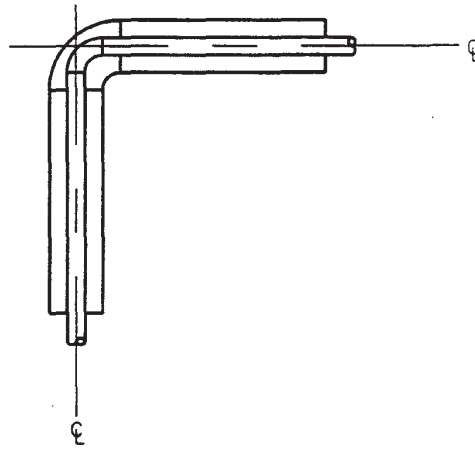

a. Before Thermal Expansion

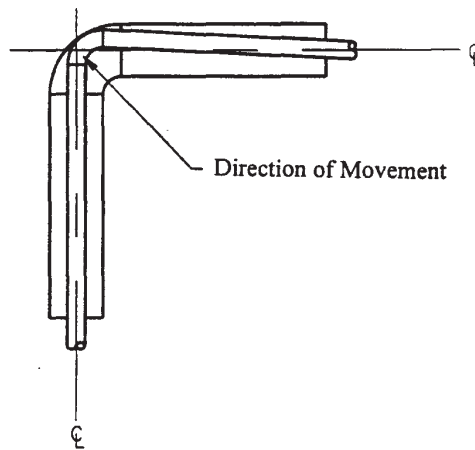

b. After Thermal Expansion

Figure 8-1. Primary Piping Thermal Expansion
(Source: SAIC, 1998)

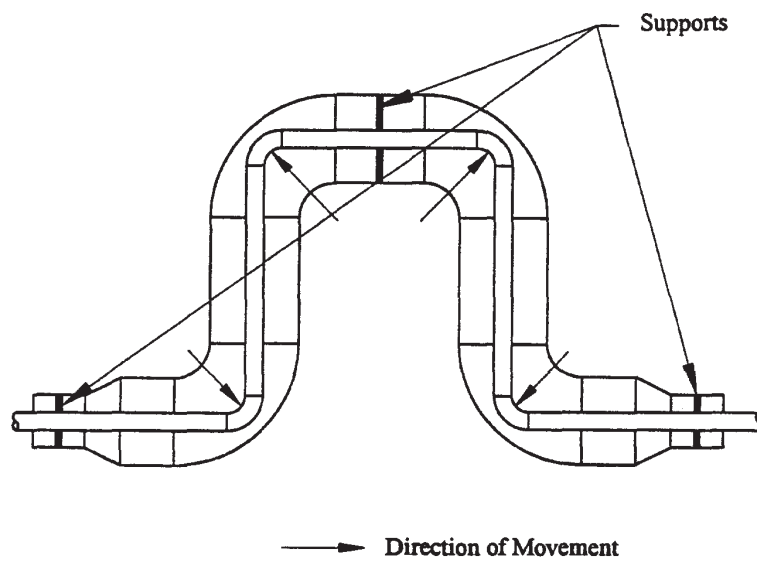

Figure 8-2. Double Containment Piping Expansion Loop Configuration
(Source: SAIC, 1998)

If the value of the combined stress, S_c , is less than the design stress rating of the secondary piping material, then the totally restrained design can be used.

When double containment piping systems are buried, and the secondary piping system has a larger temperature change than the primary system, the ground will generally provide enough friction to prevent movement of the outer pipe. However, if extreme temperature differentials are expected, it may be necessary to install vaults or trenches to accommodate expansion joints and loops.

For double containment systems located above grade, with secondary piping systems that have a larger temperature differential than primary systems, two common solutions are used. First, expansion joints in the outer piping can accommodate the movement. Second, the secondary piping can be insulated and heat traced to reduce the potential expansion-contraction changes. The latter would be particularly effective with processes that produce constant temperature liquids; therefore, the primary piping is relatively constant.

e. Piping Support

Support design for double containment piping systems heeds the same guidelines as for the piping material used to construct the containment system. The support design is also based on the outside (containment) pipe size. Spans for single piping systems of the same material as the outer pipe may be used. The same recommendations may be applied for burial of double containment piping systems as for the outer containment pipe material.

The following equation approximates the maximum spacing of the secondary piping system guides, or interstitial supports. The maximum guide spacing should be compared to the maximum hanger spacing (at maximum operating temperature) and the lesser distance used. However, the flexibility of the system should still be analyzed using piping stress calculations to demonstrate that elastic parameters are satisfied³.

$$l_g = \left(\frac{48 f E I}{4 Z S_c} \right)^{0.5}$$

where:

- l_g = maximum span between guides, mm (in)
- f = allowable sag, mm (in)
- E = modulus of elasticity, MPa (psi)
- I = moment of inertia, mm⁴ (in⁴)
- Z = section modulus, mm³ (in³)
- S_c = combined stress, MPa (psi)

8-2. Piping System Sizing

The method for sizing of the carrier pipe is identical to the methods required for single wall piping systems; see previous chapters.

a. Secondary Pipe

Secondary piping systems have more factors that must be considered during sizing. These factors include secondary piping function (drain or holding), pressurized or non-pressurized requirements, fabrication requirements, and type of leak detection system. The assumption has to be made that at some point the primary piping system will leak and have to be repaired, thus requiring the capability to drain and vent the secondary piping system. Most systems drain material collected by the secondary piping system into a collection vessel. Pressurized systems, if used, are generally only used with continuous leak detection methods, due to the required compartmentalization of the other leak detection systems.

Friction loss due to liquid flow in pressurized secondary piping systems is determined using the standard equations for flow in pipes with the exception that the hydraulic diameter is used, and friction losses due to the primary piping system supports have to be estimated. The hydraulic diameter may be determined from:

$$D_h = d_i - D_o$$

where:

- D_h = hydraulic diameter, mm (in)
- d_i = secondary pipe inside diameter, mm (in)
- D_o = primary pipe outside diameter, mm (in)

³ Schweitzer, Corrosion-Resistant Piping Systems, p. 420.

In addition, for double containment piping systems that have multiple primary pipes inside of a single secondary piping system, pressurized flow parameters can be calculated using shell and tube heat exchanger approximations (for more information, refer to the additional references listed in Paragraph A-4 of Appendix A).

8-3. Double Containment Piping System Testing

The design of double containment piping systems includes the provision for pressure testing both the primary and secondary systems. Testing is specified in the same manner as other process piping systems. The design of each piping system contains the necessary devices required for safe and proper operation including pressure relief, air vents, and drains.

Pressurized secondary piping systems are equipped with pressure relief devices, one per compartment, as appropriate. Care should be taken with the placement of these devices to avoid spills to the environment or hazards to operators.

Low points of the secondary piping system should be equipped with drains, and high points should be equipped with vents. If compartmentalized, each compartment must be equipped with at least one drain and one vent. Drains and vents need to be sized to allow total drainage of liquid from the annular space that may result from leaks or flushing. The following equations can be used for sizing⁴:

Step 1. Drainage Flow through Drain.

$$t = \int \frac{A_a}{C_d A_D \sqrt{2 g h}} dh, \text{ for } h_1 - h_2$$

where:

- t = time, s
- A_a = annular area, m² (ft²)
- C_d = C_cC_v
- C_c = coefficient of contraction, see Table 8-2
- C_v = coefficient of velocity, see Table 8-2
- A_D = area of drain opening, m² (ft²)
- g = gravitational acceleration, 9.81 m/s² (32.2 ft/s²)
- h = fluid head, m (ft)

Step 2. Flushing Flow through Drain.

$$t = \int \frac{A_a}{[(C_d A_D \sqrt{2 g h}) - Q_f]} dh, \text{ for } h_1 - h_2$$

where:

- Q_f = flushing liquid flow rate, m³/s (ft³/s)
- t = time, s
- A_a = annular area, m² (ft²)
- C_d = C_cC_v
- C_c = coefficient of contraction, see Table 8-2
- C_v = coefficient of velocity, see Table 8-2
- A_D = area of drain opening, m² (ft²)
- g = gravitational acceleration, 9.81 m/s² (32.2 ft/s²)
- h = fluid head, m (ft)

Table 8-2 Common Orifice Coefficients		
Condition	C _v	C _c
Short tube with no separation of fluid flow from walls	0.82	1.00
Short tube with rounded entrance	0.98	0.99

Source: Reprinted from Schweitzer, *Corrosion-Resistant Piping Systems*, p. 414, by courtesy of Marcel Dekker, Inc.

⁴ Schweitzer, *Corrosion-Resistant Piping Systems*, pp. 414-415.

8-4. Leak Detection Systems

Leak detection is one of the main principles of double containment piping systems. Any fluid leakage is to be contained by the secondary piping until the secondary piping can be drained, flushed, and cleaned; and the primary piping system failure can be repaired. Without leak detection, the potential exists to compromise the secondary piping system and release a hazardous substance into the environment. Early in the design of a double containment piping system, the objectives of leak detection are established in order to determine the best methods to achieve the objectives. Objectives include:

- need to locate leaks;
- required response time;
- system reliability demands; and
- operation and maintenance requirements.

a. Cable Leak Detection Systems

Cable detection systems are a continuous monitoring method. The purpose of this method is to measure the electrical properties (conductance or impedance) of a cable; when properties change, a leak has occurred. These systems are relatively expensive compared to the other methods of leak detection. Many of the commercially available systems can determine when a leak has occurred, and can also define the location of the leak. Conductance cable systems can detect the immediate presence of small leaks, and impedance systems can detect multiple leaks. However, it must be remembered that these types of systems are sophisticated electronic systems and that there may be problems with false alarms, power outages, and corroded cables⁵. Design requirements for these systems include: access, control panel uninterruptible power supply (UPS), and installation requirements.

Access ports should be provided in the secondary piping system for installation and maintenance purposes. The ports should be spaced similar to any other electrical wiring:

- at the cable entry into and exit from each pipe run;
- after every two changes in direction;
- at tee branches and lateral connections;
- at splices or cable branch connections; and
- after every 30.5 m (100 feet) of straight run.

Power surges or temporary outages will set off alarms. To avoid such occurrences, consideration should be given to UPS.

Installation requirements for a cable system include the completing of testing and thorough cleaning and drying of the secondary piping system prior to installation to avoid false alarms. In addition, a minimum annular clearance of 18 mm (3/4 in) for conductance cables and 38 to 50 mm (1-1/2 to 2 inches) for impedance cables is required to allow installation. These values may vary between manufacturers.

b. Probe Systems

Probes that measure the presence of liquids through conductivity, pH, liquid level, moisture, specific ion concentrations, pressure, and other methods are used as sensing elements in leak detection systems. The double containment piping systems are separated into compartments with each compartment containing a probe with probe systems. Leaks can only be located to the extent to which the compartment senses liquid in the secondary containment piping.

c. Visual Systems

Visual systems include the use of sumps and traps; installation of sight glasses into the secondary piping system; equipping the secondary piping system with clear traps; and use of a clear secondary piping material. Some manufacturers offer clear PVC. Visual systems are often used in addition to other leak detection methods.

⁵ Schweitzer, Corrosion-Resistant Piping Systems, p. 412.

**Chapter 9
Lined Piping Systems**

9-1. General

When properly utilized, a lined piping system is an effective means by which to protect metallic piping from internal corrosion while maintaining system strength and external impact resistance. Cathodic protection is still required for buried applications to address external corrosion. Manufacturing standard options for the outer piping material are usually Schedule 40 or 80 carbon steel. Lined piping systems are not double containment piping systems.

a. Design Parameters

Design factors that must be taken into account for the engineering of lined piping systems include: pressure, temperature and flow considerations; liner selection factors of permeation, absorption, and stress cracking; and heat tracing, venting and other installation requirements.

b. Operating Pressures and Temperatures

The requirements for addressing pressure and temperature conditions for lined piping systems are summarized in the following paragraphs.

Lined piping systems are used primarily for handling corrosive fluids in applications where the operating pressures and temperatures require the mechanical strength of metallic pipe. Therefore, the determination of maximum steady state design pressure is based on the same procedure and requirements as metallic pipe shell, and the design temperature is based on similar procedures and requirements as thermoplastic pipe.

Table 9-1 lists recommended temperature limits of thermoplastic used as liners. The temperature limits are based on material tests and do not necessarily reflect evidence of successful use as piping component linings in specific fluid serviced at the temperatures listed. The manufacturer is consulted for specific application limitations.

c. Liner Selection

Liner selection for piping systems must consider the materials being carried (chemical types and concentrations, abrasives, flow rates), the operating conditions (flow, temperature, pressure), and external situations (high temperature potential).

For the material compatibility of metallic lined piping system with various chemicals, see Appendix B. As discussed in Chapter 4, metallic material compatibility should consider the type and concentration of chemicals

Table 9-1 Thermoplastic Liner Temperature Limits (Continuous Duty)				
Materials	Recommended Temperature Limits			
	Minimum		Maximum	
	°F	°C	°F	°C
ECTFE	-325	-198	340	171
ETFE	-325	-198	300	149
FEP	-325	-198	400	204
PFA	-325	-198	500	260
PP	0	-18	225	107
PTFE	-325	-198	500	260
PVDC	0	-18	175	79
PFDF	0	-18	275	135

Note: Temperature compatibility should be confirmed with manufacturers before use is specified.
Source: ASME B31.3, p. 96, Reprinted by permission of ASME.

in the liquid, liquid temperature and total stress of the piping system. The selection of materials of construction should be made by an engineer experienced in corrosion or similar applications. See Appendix A, Paragraph A-4, for additional sources of corrosion data.

As discussed in Chapter 5, thermoplastic materials do not display corrosion rates and are, therefore, either completely resistant to a chemical or will rapidly deteriorate. Plastic lined piping system material failure occurs primarily by the following mechanisms: absorption, permeation, environmental-stress cracking, and combinations of the above mechanisms.

Permeation of chemicals may not affect the liner but may cause corrosion of the outer metallic piping. The main design factors that affect the rate of permeation include absorption, temperature, pressure, concentration, and liner density and thickness. As temperature, pressure, and concentration of the chemical in the liquid increase, the rate of permeation is likely to increase. On the other hand, as liner material density and thickness increase, permeation rates tend to decrease¹.

For plastic material compatibility with various chemicals, see Appendix B. See Appendix A, Paragraph A-4, for additional sources of corrosion data. For the material compatibility of elastomeric and rubber as well as other nonmetallic material lined piping systems with various chemicals, see appendix B.

Liners should not be affected by erosion with liquid velocities of less than or equal to 3.66 m/s (12 ft/s) when abrasives are not present. If slurries are to be handled, lined piping is best used with a 50% or greater solids content and liquid velocities in the range of 0.61 to 1.22 m/s (2 to 4 ft/s). Particle size also has an effect on erosion. Significant erosion occurs at >100 mesh; some erosion occurs at >250 but <100 mesh; and little erosion occurs at <250 mesh. Recommended liners for slurry applications are PVDF and PTFE, and soft rubber; by comparison, in a corrosive slurry application, PP erodes 2 times as fast and carbon steel erodes 6.5 times as fast².

d. Joining

Two available methods for joining lined pipe are flanged joints and mechanical couplings (in conjunction with heat fusion of the thermoplastic liners).

Thermoplastic spacers are used for making connections between lined steel pipe and other types of pipe and equipment. The spacer provides a positive seal. The bore of the spacer is the same as the internal diameter (D_i) of the lined pipe. Often, a gasket is added between the spacer and a dissimilar material to assist in providing a good seal and to protect the spacer.

When connecting lined pipe to an unlined flat face flange, a 12.7 mm ($\frac{1}{2}$ in) thick plastic spacer of the same material as the pipe liner is used. A gasket and a spacer will connect to an unlined raised face flange. Both a gasket and a spacer is recommended to connect to glass-lined equipment nozzles. Install a 12.7 mm ($\frac{1}{2}$ in) thick spacer between lined pipe or fittings and other plastic-lined components, particularly valves, if the diameters of the raised plastic faces are different.

For small angle direction changes, tapered face spacers may be used³. It is not recommended to exceed a five degree directional change using a tapered face spacer. For directional changes greater than five degrees, precision-bent fabricated pipe sections are available from lined pipe manufacturers.

Gaskets are not necessary to attain a good seal between sections of thermoplastic lined pipe, if recommended fabrication and installation practices are followed. Often, leaks result from using insufficient torque when trying to seal a joint. The addition of a gasket provides a softer material which seals under the lesser stress developed by low torque. When gaskets or any dissimilar materials are used in the pipe joint, the lowest recommended torque for the materials in the joint is always used.

Gaskets are put in when previously used lined pipe is reinstalled following maintenance. Gaskets are also used between plastic spacers and non-plastic-lined pipe, valves, or fittings.

¹ Schweitzer, *Corrosion-Resistant Piping Systems*, pp.149-151.

² *Ibid.*, p. 153.

³ Crane/Resistoflex, "Plastic Lined Piping Products Engineering Manual," p. 41.

The recommended bolt torque values for thermoplastic lined piping systems are shown on Tables 9-2 through 9-5. Excessive torque causes damage to the plastic sealing surfaces. When bolting together dissimilar materials, the lowest recommended torque of the components in the joint is used.

Bolting torque is rechecked approximately 24 hours after the initial installation or after the first thermal cycle. This is required to reseal the plastic and allow for relaxation of the bolts. Bolting is performed only on the system in the ambient, cooled state, and never while the process is at elevated temperature or excessive force could result upon cooling.

e. Thermal Expansion

Thermal expansion design for lined piping systems can be handled in a similar manner as metallic piping. Expansion joints have been used to compensate for thermal expansion. However, expansion joints are usually considered the weakest component in a piping system and are usually eliminated through good engineering practices. Due to the bonding between the liner and the metallic pipe casing, pre-manufactured sections of pipe designed to allow for changes in movement of the piping system are available from manufacturers.

On long straight pipe runs, lined pipe is treated similarly to carbon steel piping. Changes in direction in pipe runs are introduced wherever possible to allow thermal expansion.

A common problem is the installation of lined piping between a pump and another piece of equipment. On new installations, equipment can be laid out such that there are no direct piping runs. Where a constricted layout is required or a piping loop would not be practical, the solution is to allow the pump to "float." The pump-motor base assemblies are mounted on a platform with legs. These bases are available from several manufacturers or can be constructed. These bases allow movement in order to relieve the stresses in the piping system.

f. Heat Tracing and Insulation

Heat tracing, insulation, and cladding can be installed on lined piping systems when required. The key for the design is to not exceed the maximum allowable temperature of the lining. Manufacturers recommendations on electrical heat tracing design should be followed to avoid localized hot spots. Steam heat tracing should not be used with most plastic lined piping systems due to the high temperature potential. Venting is required on many lined piping systems to allow for permeating vapor release. If insulation or cladding is to be mounted on the piping system, vent extenders should be specified to extend past the potential blockage.

g. Piping Support and Burial

Design of support systems for lined piping systems follows the same guidelines as for the outer piping material. Spans for systems consisting of the material used in the outer pipe may be used. Supports should permit the pipe to move freely with thermal expansion and contraction. The design requirements for buried lined piping systems are the same as those for the outer piping material. That is, a buried plastic lined carbon steel pipe should be treated the same way as a carbon steel pipe without a liner.

9-2. Plastic Lined Piping Systems

Thermoplastic lined piping systems are commonly used and widely available commercially under a variety of trade names. Table 9-6 presents a summary of some of the material properties for plastic liners, and Table 9-7 lists some of the liner thicknesses used for the protection of oil production equipment when applied as a liquid coating. Standard liner thicknesses are 3.3 to 8.6 mm (0.130 to 0.340 inches).

a. Common Plastic Liners

Most thermoplastics can be used as liner material. However, the more common and commercially available plastic liners include polyvinylidene chloride, perfluoroalkoxyl, polypropylene, polytetrafluoroethylene, and polyvinylidene fluoride.

Table 9-2 ANSI Class 125 and Class 150 Systems (Lightly Oiled Bolting)						
Pipe Size, mm (in)	Number of Bolts	Bolt Diameter mm (in)	Bolt Torque, N-m (ft-lb)			
			PVDC	PP	PVDF	PTFE
25 (1)	4	14 (½)	41 (30)	37 (35)	75 (55)	34 (25)
40 (1½)	4	14 (½)	54 (40)	102 (75)	81 (60)	75 (55)
50 (2)	4	16 (5/8)	61 (45)	149 (110)	169 (125)	102 (75)
65 (2½)	4	16 (5/8)	75 (55)	169 (125)	N.A.	N.A.
80 (3)	4	16 (5/8)	95 (70)	169 (125)	169 (125)	149 (110)
100 (4)	8	16 (5/8)	68 (50)	190 (140)	169 (125)	129 (95)
150 (6)	8	20 (¾)	129 (95)	305 (225)	305 (225)	169 (125)
200 (8)	8	20 (¾)	217 (160)	305 (225)	305 (225)	258 (190)
250 (10)	12	24 (7/8)	N.A.	468 (345)	N.A.	271 (200)

Notes: These torques are only valid for lightly oiled ASTM A 193 bolts and nuts. Lightly oiled is considered WD-40 (WD-40 is a registered trademark of WD-40 Company, San Diego, CA) or equivalent.
N.A. = Part is not available from source.

Source: Crane/Resistoflex, "Plastic Lined Piping Products Engineering Manual," p. 54.

TABLE 9-3 ANSI Class 300 Systems (Lightly Oiled Bolting)						
Pipe Size mm (in)	Number of Bolts	Bolt Diameter mm (in)	Bolt Torque, N-m (ft-lb)			
			PVDC	PP	PVDF	PTFE
25 (1)	4	16 (5/8)	37 (35)	61 (45)	95 (70)	41 (30)
40 (1½)	4	16 (5/8)	81 (60)	149 (110)	230 (170)	108 (80)
50 (2)	8	16 (5/8)	34 (25)	75 (55)	115 (85)	54 (40)
80 (3)	8	20 (¾)	54 (40)	136 (100)	210 (155)	88 (65)
100 (4)	8	20 (¾)	81 (60)	230 (170)	305 (225)	149 (110)
150 (6)	12	20 (¾)	88 (65)	224 (165)	305 (225)	115 (85)
200 (8)	12	24 (7/8)	169 (125)	441 (325)	495 (365)	203 (150)

Note: These torques are only valid for lightly oiled ASTM A 193, B7 bolts and ASTM A 194, 2H nuts. Lightly oiled is considered WD-40 (WD-40 is a registered trademark of WD-40 Company, San Diego, CA) or equivalent.

Source: Crane/Resistoflex, "Plastic Lined Piping Products Engineering Manual," p. 54.

Table 9-4 ANSI Class 125 and Class 150 Systems (Teflon - Coated Bolting)						
Pipe Size, mm (in)	Number of Bolts	Bolt Diameter mm (in)	Bolt Torque N-m (ft-lb)			
			PVDC	PP	PVDF	PTFE
25 (1)	4	14 (½)	27 (20)	34 (25)	54 (40)	20 (15)
40 (1½)	4	14 (½)	41 (30)	75 (55)	61 (45)	54 (40)
50 (2)	4	16 (5/8)	41 (30)	95 (70)	122 (90)	68 (50)
65 (2½)	4	16 (5/8)	37 (35)	122 (90)	N.A.	N.A.
80 (3)	4	16 (5/8)	68 (50)	122 (90)	122 (90)	95 (70)
100 (4)	8	16 (5/8)	37 (35)	122 (90)	122 (90)	81 (60)
150 (6)	8	20 (¾)	41 (30)	102 (75)	102 (75)	68 (50)
200 (8)	8	20 (¾)	75 (55)	102 (75)	102 (75)	102 (75)
250 (10)	12	24 (7/8)	N.A.	339 (250)	N.A.	203 (150)
300 (12)	12	24 (7/8)	N.A.	339 (250)	N.A.	271 (200)

Notes: These torques are valid only for Teflon-coated ASTM A 193, B7 bolts and ASTM A 194, 2H nuts.
N.A. = Part is not available from source.

Source: Crane/Resistoflex, "Plastic Lined Piping Products Engineering Manual," p. 55.

TABLE 9-5 ANSI Class 300 Systems (Teflon - Coated Bolting)						
Pipe Size mm (in)	Number of Bolts	Bolt Diameter mm (in)	Bolt Torque N-m (ft-lb)			
			PVDC	PP	PVDF	PTFE
25 (1)	4	16 (5/8)	41 (30)	37 (35)	61 (45)	27 (20)
40 (1½)	4	20 (¾)	34 (25)	61 (45)	95 (70)	41 (30)
50 (2)	8	16 (5/8)	27 (20)	61 (45)	95 (70)	41 (30)
80 (3)	8	20 (¾)	34 (25)	61 (45)	81 (60)	34 (25)
100 (4)	8	20 (¾)	41 (30)	95 (70)	102 (75)	61 (45)
150 (6)	12	20 (¾)	41 (30)	95 (70)	102 (75)	37 (35)
200 (8)	12	24 (7/8)	129 (95)	312 (230)	346 (255)	163 (120)

Notes: These torques are valid only for Teflon-coated ASTM A 193, B7 bolts and ASTM A 194, 2H nuts.

Source: Crane/Resistoflex, "Plastic Lined Piping Products Engineering Manual," p. 55.

Table 9-6 Plastic Liner Material Properties					
Liner Material	Shell Material	Specific Gravity	Tensile Strength, MPa (psi)	Available Size Range, mm (in)	Maximum Temperature, °C (°F)
PVC	--	1.45	41.4 (6,000)	--	82 (180)
PVDC	carbon steel	1.75	18.6 (2,700)	25 to 200 (1 to 8)	79 (175)
PE	carbon steel, aluminum	0.94	8.27 (1,200)	50 to 200 (2 to 8)	66 (150)
PP	carbon steel	0.91	31.0 (4,500)	25 to 300 (1 to 12)	107 (225)
PTFE	carbon steel, TP304L stainless steel	2.17	17.2 (2,500)	25 to 300 (1 to 12)	232 (450)
FEP	carbon steel	2.15	23.4 (3,400)	25 to 750 (1 to 30)	204 (400)
PFA	carbon steel	2.15	24.8 (3,600)	25 to 750 (1 to 30)	260 (500)
ETFE	carbon steel	1.7	44.8 (6,500)	as required*	150 (300)
PVDF	carbon steel	1.78	31.0 (4,500)	25 to 200 (1 to 8)	135 (275)
ECTFE	carbon steel, stainless steel	1.68	48.3 (7,000)	25 to 200 (1 to 8)	150 (300)

Note: *Typically liquid applied; availability based upon shell piping availability.
Source: Compiled by SAIC, 1998; note that confirmation is required from the specific vendor for a selected product.

Table 9-7 Liquid-Applied Coating Thickness	
Material	Total Dry Film Thickness Range
Fluoropolymers (ETFE, ECTFE)	50 to 125 µm (2 to 5 mils)
PVDF	500 to 1,500 µm (20 to 60 mils)

Source: NACE, RP 0181-94, p. 3.

Polytetrafluoroethylene (PTFE) is a fully fluorinated polymer. Although PTFE is chemically inert to most materials, some chemicals will permeate through the liner. Therefore, venting of the joint area between the liner and outer casing is required⁴. PTFE materials are produced in accordance with ASTM D 1457 with material parameters specified by the designation of type (I through VIII) and class (specific to each type). The manufacture of PTFE lined pipe and materials are in accordance with ASTM F 423.

Polyvinylidene fluoride (PVDF) is similar to PTFE but is not fully fluorinated. PVDF liners can be produced with sufficient thickness to prevent permeation of gases (see Table 9-8) so that liner venting is not required⁵. PVDF resins are produced in accordance with ASTM D 3222 with material parameters specified by the designation of either type 1 (class 1 or 2) or type 2. PVDF lined pipe and fittings are manufactured to conform to ASTM F 491.

Polyvinylidene chloride (PVDC) is a proprietary product of Dow Chemical (trade name Saran). PVDC is often used in applications where purity protection is critical. PFA resins are manufactured according to ASTM D 729, and lined piping and fittings are manufactured to conform to ASTM F 599.

Polypropylene (PP) lined pipe is typically inexpensive compared to other lined plastic piping systems. In addition, PP does not allow permeation; therefore, liner venting is not required⁶. Physical parameters (e.g., density, tensile strength, flexural modulus) of PP materials are specified by cell classification pursuant to ASTM D 4101. Additional material requirements may be added using the ASTM D 4000 suffixes; for example, W = weather resistant. The manufacture of PP lined pipe and materials are in accordance with ASTM F 492.

Perfluoroalkoxyl (PFA) is a fully fluorinated polymer that is not affected by chemicals commonly found in chemical processes. Depending upon process conditions PFA will absorb some liquids, however, including benzaldehyde,

carbon tetrachloride, toluene, ferric chloride, hydrochloric acid, and other liquids. PFA lacks the physical strength of PTFE at higher temperatures and fails at 1/4 of the life of PTFE under flexibility tests⁷. PFA resins are manufactured according to ASTM D 3307, and lined piping and fittings are manufactured to conform to ASTM F 781.

**Table 9-8
Typical PVDF Liner Thickness
Required to Prevent Permeation**

Nominal Pipe Size, mm (in)	Liner Thickness, mm (in)
25 (1)	3.81 (0.150)
40 (1 ½)	4.07 (0.160)
50 (2)	4.37 (0.172)
80 (3)	4.45 (0.175)
100 (4)	5.26 (0.207)
150 (6)	5.54 (0.218)
200 (8)	5.54 (0.218)

Source: Reprinted from Schweitzer, Corrosion-Resistant Piping Systems, p. 182, by courtesy of Marcel Dekker, Inc.

b. Plastic Lined Piping Construction

As discussed in Paragraph 9-1d, plastic lined pipe piping is joined using flanges or mechanical couplings and fittings that are normally flanged. Some manufacturers can provide pre-bent pipe sections to avoid the use of flanged elbows. Use of pre-bent pipe sections requires

⁴ Schweitzer, Corrosion-Resistant Piping Systems, pp. 161-162.

⁵ Ibid., p. 165.

⁶ Ibid., p. 166.

⁷ Ibid., p. 164.

that the design take into account the manufacturer's standard bend radius which is often larger than the bend radius for conventional elbows.

9-3. Other Lined Piping Systems

The elastomer and rubber materials most commonly used as liner materials include natural rubber, neoprene, butyl, chlorobutyl, nitrile, and EPDM, which tend to be less expensive than other liners. Design criteria that need to be considered before selecting elastomeric and rubber lined piping systems include: corrosion resistance, abrasion resistance, maximum operating temperature, and potential contamination of conveyed material.

Elastomeric and rubber linings vary in thickness from 3.2 to 6.4 mm (1/8 to 1/4 in). Lined pipe is available from 40 to 250 mm (1½ to 10 in), standard, at ratings of 1.03

MPa (150 psi) or 2.06 MPa (300 psi). Joining is typically accomplished through the use of flanges.

Glass-lined piping systems are commercially available with carbon steel outer piping in sizes of 25 to 300 mm (1 to 12 in), standard. Joining is accomplished using class 150 split flanges, although class 300 split flanges are also available as options. A PTFE envelope gasket is recommended⁸. Stress is to be avoided; expansion joints should be used to isolate vibration and other stresses from the piping system. Sudden changes in process temperatures should also be avoided.

Nickel-lined piping systems are available in sizes from 40 to 600 mm (1½ to 24 in) with liner thickness of 0.0008 to 0.015 inches. Joining is accomplished either by welding or flanging, with welding the preferred method⁹.

⁸ Schweitzer, Corrosion-Resistant Piping Systems, p. 198.

⁹ Ibid., p. 199.

Chapter 10

Valves

10-1. General

For liquid piping systems, valves are the controlling element. Valves are used to isolate equipment and piping systems, regulate flow, prevent backflow, and regulate and relieve pressure. The most suitable valve must be carefully selected for the piping system. The minimum design or selection parameters for the valve most suitable for an application are the following: size, material of construction, pressure and temperature ratings, and end connections. In addition, if the valve is to be used for control purposes, additional parameters must be defined. These parameters include: method of operation, maximum and minimum flow capacity requirement, pressure drop during normal flowing conditions, pressure drop at shutoff, and maximum and minimum inlet pressure at the valve. These parameters are met by selecting body styles, material of construction, seats, packing, end connections, operators and supports.

a. Body Styles

The control valve body type selection requires a combination of valve body style, material, and trim considerations to allow for the best application for the intended service.

Valve body styles have different flow characteristics as they open from 0 to 100%. The flow rate through each type or body style will vary according to different curves with constant pressure drops. This is referred to as the valve flow characteristics. A quick opening flow characteristic produces a large flow rate change with minimal valve travel until the valve plug nears a wide open position. At that point, the flow rate change is minimal with valve travel. A linear flow characteristic is one that has a flow rate directly proportional to valve travel. An equal percentage flow characteristic is one in which a flow rate change is proportional to the flow rate just prior to the change in valve position. Equal increments of valve travel result in equal percentage changes to the existing flow rate. That is, with a valve nearly closed (existing flow rate is small), a large valve travel will result in a small flow rate change, and a large flow rate change will occur when the valve is almost completely open, regardless of the amount of valve travel.

The purpose of characterizing control valves is to allow for relatively uniform control stability over the expected operating range of the piping system. A design goal is to match a control valve flow characteristic to the specific system. Figure 10-1 illustrates some typical flow characteristic curves for control valves.

Table 10-1 provides guidelines for the selection of proper flow characteristics. There are exceptions to these guidelines, and a complete dynamic analysis is performed on the piping system to obtain a definite characteristic. Quick opening valves are primarily used for open/close applications (or on/off service) but may also be appropriate for applications requiring near linear flow. For processes that have highly varying pressure drop operating conditions, an equal percentage valve may be appropriate.

b. Material of Construction

The selection of valve body material and trim material is typically based on pressure, temperature, corrosive and erosive properties of the liquid. Table 10-2 provides basic information on typical castable materials used for control valve bodies. Certain service conditions require other alloys and metals to withstand corrosive and erosive properties of the liquid. The materials that can be used for these situations are similar to the piping materials; therefore, the material fluid matrix found in Appendix B can be used as a guide to select materials for these special conditions. The use of non-standard materials is much more expensive than the use of standard valve body materials.

c. Seats

Valve seats are an integral part of a valve. The materials for valve seats are specified under valve trim for each valve. As such, valve seats are manufacturer specific and should not be interchanged. Seat material is selected for compatibility with the fluid. Valve seats can be either metallic or non-metallic. The fluid/material matrix found in Appendix B may be used to assist in material selection. Table 10-3 provides a wear and galling resistance chart for different metallic valve plug and seat combinations. Table 10-4 provides general information for elastomers used in valve seats.

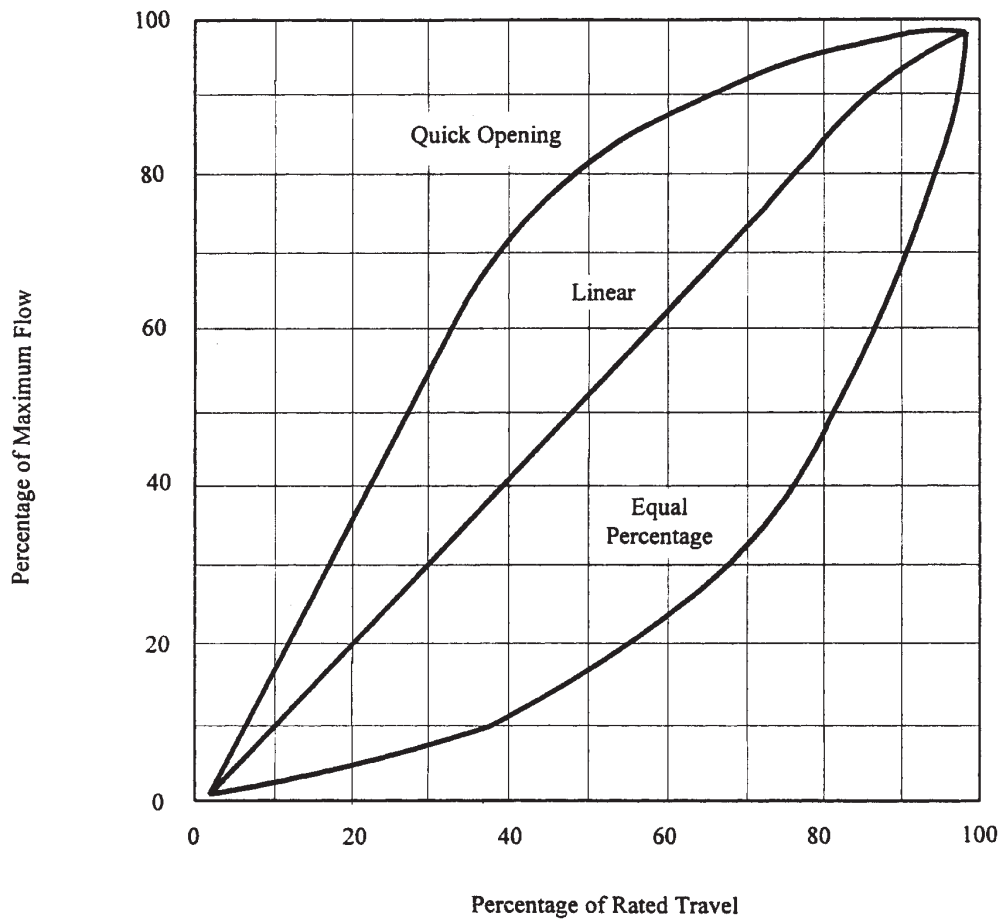

Figure 10-1. Valve Flow Characteristics
(Source: Fisher, *Control Valve Handbook*, 2nd Ed., p. 60.)

Table 10-1 Recommended Flow Characteristics		
Control System	Application	Recommended Flow Characteristic
Liquid Level	Constant ΔP .	Linear
Liquid Level	Decreasing ΔP with increasing flow; $\Delta P_{\min} > 20\% \Delta P_{\max}$.	Linear
Liquid Level	Decreasing ΔP with increasing flow; $\Delta P_{\min} < 20\% \Delta P_{\max}$.	Equal Percentage
Liquid Level	Increasing ΔP with increasing flow; $\Delta P_{\max} < 200\% \Delta P_{\min}$.	Linear
Liquid Level	Increasing ΔP with increasing flow; $\Delta P_{\max} > 200\% \Delta P_{\min}$.	Quick Opening
Flow	Measurement signal proportional to flow; valve in series with measurement device; wide range of flow required.	Linear
Flow	Measurement signal proportional to flow; valve in series with measurement device; small range of flow required with large ΔP change for increasing flow.	Equal Percentage
Flow	Measurement signal proportional to flow; valve in parallel (bypass) with measurement device; wide range of flow required.	Linear
Flow	Measurement signal proportional to flow; valve in parallel (bypass) with measurement device; small range of flow required with large ΔP change for increasing flow.	Equal Percentage
Flow	Measurement signal proportional to flow squared; valve in series with measurement device; wide range of flow required.	Linear
Flow	Measurement signal proportional to flow squared; valve in series with measurement device; small range of flow required with large ΔP change for increasing flow.	Equal Percentage
Flow	Measurement signal proportional to flow squared; valve in parallel (bypass) with measurement device; wide range of flow required.	Equal Percentage
Flow	Measurement signal proportional to flow squared; valve in parallel (bypass) with measurement device; small range of flow required with large ΔP change for increasing flow.	Equal Percentage
Pressure	All.	Equal Percentage

Source: Control Valve Handbook, Fisher Controls Company, pp. 61-62.

Table 10-2 Standard Control Valve Body Materials		
Cast Material	Standard	Comments
Carbon Steel	ASTM A 216 Gr. WCB	Moderate services such as non-corrosive liquids. Higher pressures and temperatures than cast iron. Check codes for suitability at extended high temperatures.
Chrome-Moly Steel	ASTM A 217, Gr. C5	Used for mildly corrosive fluids such as sea water, oils. Resistant to erosion and creep at high temperatures. Can be used to 595°C (1,100°F).
Type 304 Stainless Steel	ASTM A 351, Gr. CF8	Used for oxidizing or very corrosive fluids (see Appendix C). Can be used above 540°C (1,000°F).
Type 316 Stainless Steel	ASTM A 351, Gr. CF8M	Used for oxidizing or very corrosive fluids, resistant to corrosion pitting and creep (see Appendix C). Provides greater strength than 304 S.S.
Monel	ASTM A 494 Gr. M35-1	Resistant to nonoxidizing acids. Used with seawater and other mildly corrosive fluids at high temperatures. Expensive.
Hastelloy-C	ASTM A 494 Gr. CW2N	Used particularly with chlorine and chloride compounds. Expensive.
Iron	ASTM A 126 Class B	Inexpensive and non-ductile. Used for water and non-corrosive liquids.
Bronze	ASTM B 61 and B 62	ASTM B 61 typically used for trim. ASTM B 62 typically used for valve body. Can be used for water and dilute acid service (see Appendix B).
Note: Gr. = grade; grade designation pursuant to the referenced standard. Source: Compiled by SAIC, 1998.		

**Table 10-3
Wear and Galling Resistance Chart of Material Combinations**

	304 SS	316 SS	Bronze	Inconel	Monel	Hastelloy B	Hastelloy C	Titanium 75A	Nickel	Alloy 20	Type 416 Hard	Type 440 Hard	Alloy 6 (Co-Cr)	Cr-Plate	Al-Bronze
304 SS	P	P	F	P	P	P	F	P	P	P	F	F	F	F	F
316 SS	P	P	F	P	P	P	F	P	P	P	F	F	F	F	F
Bronze	F	F	S	S	S	S	S	S	S	S	F	F	F	F	F
Inconel	P	P	S	P	P	P	F	P	F	F	F	F	F	F	S
Monel	P	P	S	P	P	P	F	F	F	F	F	F	S	F	S
Hastelloy B	P	P	S	P	P	P	F	F	S	F	F	F	S	S	S
Hastelloy C	F	F	S	F	F	F	F	F	F	F	F	F	S	S	S
Titanium 75A	P	P	S	P	P	P	F	P	F	F	F	F	S	F	S
Nickel	P	P	S	F	F	F	F	P	P	P	F	F	S	F	S
Alloy 20	P	P	S	F	F	F	F	P	P	P	F	F	S	F	S
Type 416 Hard	F	F	F	F	F	F	F	F	F	F	F	F	S	S	S
Type 440 Hard	F	F	F	F	F	F	F	F	F	F	S	F	S	S	S
17-4 PH	F	F	F	F	F	F	F	F	F	F	S	F	S	S	S
Alloy 6 (Co-Cr)	F	F	F	F	F	F	F	S	S	F	F	S	F	S	S
ENC*	F	F	F	F	F	F	F	F	F	F	S	S	S	S	S
Cr Plate	F	F	F	F	F	F	F	F	F	F	S	S	S	P	S
Al Bronze	F	F	F	S	S	S	S	S	S	S	S	S	S	S	P

* Electroless nickel coating
 S - Satisfactory
 F - Fair
 P - Poor

Source: Control Valve Handbook, Fisher Controls Company, p. 49.

**Table 10-4
Elastomer General Properties**

Property	Natural Rubber	Buna-S	Nitrile	Neoprene	Butyl	Thiokol	Silicone	Hypalon	Viton ^{2,3}	Polyurethane ³	Ethylene Propylene ⁴
Tensile Strength, psi (Bar)	3000 (207) 4500 (310)	400 (28) 3000 (207)	600 (41) 4000 (276)	3500 (241) 3500 (241)	3000 (207) 3000 (207)	300 (21) 1500 (103)	200-450 (14-31) 1100 (76)	4000 (276) 4400 (303)	--- 2300 (159)	--- 6500 (448)	--- 2500 (172)
Tear Resistance	Excellent	Poor-Fair	Fair	Good	Good	Fair	Poor-Fair	Excellent	Good	Excellent	Poor
Abrasion Resistance	Excellent	Good	Good	Excellent	Fair	Poor	Poor	Excellent	Very Good	Excellent	Good
Aging: Sunlight Oxidation	Poor Good	Poor Fair	Poor Fair	Excellent Good	Excellent Good	Good Good	Good, Very Good	Excellent, Very Good	Excellent Excellent	Excellent Excellent	Excellent Good
Heat (Max. Temp.)	93 °C (200 °F)	93 °C (200 °F)	121 °C (250 °F)	93 °C (200 °F)	93 °C (200 °F)	60 °C (140 °F)	232 °C (450 °F)	149 °C (300 °F)	204 °C (400 °F)	93 °C (200 °F)	177 °C (350 °F)
Static (Shelf)	Good	Good	Good	Very Good	Good	Fair	Good	Good	---	---	Good
Flex Cracking Resistance	Excellent	Good	Good	Excellent	Excellent	Fair	Fair	Excellent	---	Excellent	---
Compression Set Resistance	Good	Good	Very Good	Excellent	Fair	Poor	Good	Poor	Poor	Good	Fair
Low Temperature Flexibility (Max.)	-54 °C (-65 °F)	-46 °C (-50 °F)	-40 °C (-40 °F)	-40 °C (-40 °F)	-40 °C (-40 °F)	-40 °C (-40 °F)	-73 °C (-100 °F)	-29 °C (-20 °F)	-34 °C (-30 °F)	-40 °C (-40 °F)	-45 °C (-50 °F)
Permeability to Gases	Fair	Fair	Fair	Very Good	Very Good	Good	Fair	Very Good	Good	Good	Good
Resilience	Very Good	Fair	Fair	Very Good	Very Good	Poor	Good	Good	Good	Fair	Very Good
Elongation (Max.)	700%	500%	500%	500%	700%	400%	300%	300%	425%	625%	500%

Notes: Trademark of Thiokol Chemical Co.
 †Trademark of E.I. DuPont Co.
 Do not use with ammonia.
 Do not use with petroleum base fluids. Use with ester base nonflammable hydraulic oils and low pressure steam applications to 300 °F (140 °C).
 See Appendix B for more details regarding fluid compatibility with elastomers.
 Source: Control Valve Handbook, Fisher Controls Company, p. 57.

In addition, the amount of valve leakage is determined based on acceptability to process and design requirements. Control valve seats are classified in accordance with ANSI/FCI 70-2-1991 for leakage. These classifications are summarized in Table 10-5 and Table 10-6.

Table 10-5 Valve Seat Leakage Classifications	
Leakage Class Designation	Maximum Allowable Leakage
I	---
II	0.5% of rated capacity
III	0.1% of rated capacity
IV	0.01% of rated capacity
V	5×10^{-12} m ³ /s of water per mm of seat diameter per bar differential (0.0005 ml/min per inch of seat diameter per psi differential)
VI	Not to exceed amounts shown in Table 10-6 (based on seat diameter)

Source: ANSI/FCI 70-2-1991

Table 10-6 Class VI Seat Allowable Leakage	
Nominal Port Diameter mm (in)	Allowable Leakage Rate (ml per minute)
≤25 (≤1)	0.15
38 (1½)	0.30
51 (2)	0.45
64 (2½)	0.60
76 (3)	0.90
102 (4)	1.70
152 (6)	4.00
203 (8)	6.75

Source: ANSI/FCI 70-2-1991

d. Packing

Most control valves use packing boxes with the packing retained and adjusted by flange and stud bolts. Several packing materials are available for use, depending upon the application. Table 10-7 provides information on some of the more typical packing arrangements.

e. End Connections

The common end connections for installing valves in pipe include screwed pipe threads, bolted gasketed flanges, welded connections, and flangeless (or wafer) valve bodies.

Screwed end connections are typically used with small valves. Threads are normally specified as tapered female National Pipe Thread (NPT). This end connection is limited to valves 50 mm (2 in) and smaller and is not recommended for elevated temperature service. This connection is also used in low maintenance or non-critical applications.

Flanged end valves are easily removed from piping and, with proper flange specifications, are suitable for use through the range of most control valve working pressures. Flanges are used on all valve sizes larger than 50 mm (2 in). The most common types of flanged end connections are flat faced, raised faced, and the ring joint. Flat faced flanges are typically used in low pressure, cast iron or brass valves and have the advantage of minimizing flange stresses. Raised faced flanges can be used for high pressure and temperature applications and are normally standard on ANSI Class 250 cast iron and on all steel and alloy steel bodies. The ring-type joint flange is typically used at extremely high pressures of up to 103 MPa (15,000 psig) but is generally not used at high temperatures. This type of flange is furnished only on steel and alloy valve bodies when specified.

Welding ends on valves have the advantage of being leak tight at all pressures and temperatures; however, welding end valves are very difficult to remove for maintenance and/or repairs. Welding ends are manufactured in two styles: socket and butt.

Flangeless valve bodies are also called wafer-style valve bodies. This body style is common to rotary shaft control valves such as butterfly valves and ball valves.

TABLE 10-7 Packing	
Type	Application
PTFE	Resistant to most chemicals. Requires extremely smooth stem finish to seal properly. Will leak if stem or packing is damaged.
Laminated/Filament Graphite	Impervious to most liquids and radiation. Can be used at high temperatures, up to 650°C (1,200°F). Produces high stem friction.
Semi-Metallic	Used for high pressures and temperatures, up to 480°C (900°F).
Fiberglass	Good for general use. Used with process temperatures up to 288°C (550°F). Ferritic steel stems require additive to inhibit pitting.
Kevlar and Graphite	Good for general use. Used with process temperatures up to 288°C (550°F). Corrosion inhibitor is included to avoid stem corrosion.
Source: Compiled by SAIC, 1998	

Flangeless bodies are clamped between two pipeline flanges by long through-bolts. One of the advantages of a wafer-style body is that it has a very short face-to-face body length.

f. Operators

Valve operators, also called actuators, are available in manual, pneumatic, electric, and hydraulic styles.

Manual operators are used where automatic control is not required. These valves may still result in good throttling control, if control is necessary. Gate, globe and stop check valves are often supplied with hand wheel operators. Ball and butterfly valves are supplied with hand levers. Manual operators can be supplied with direct mount chain wheels or extensions to actuate valves in hard-to-reach locations. Manually operated valves are often used in a three-valve bypass loop around control valves for manual control of the process during down time on the automatic system. Manual operators are much less expensive than automatic operators.

For sliding stem valves, that is, valves that are not rotary, the most common operator type is a pneumatic operator. A pneumatic operator can be a spring and diaphragm

type or a pneumatic piston. While these pneumatic operators are also available for rotary shaft valves, electrical operators tend to be more common on the rotary valves.

Spring and diaphragm operators are pneumatically operated using low pressure air supplied from a controller position or other source. Styles of these operators include direct acting, in which increasing air pressure pushes down the diaphragm and extends the actuator stem; reverse acting, in which increasing air pressure pushes up the diaphragm and retracts the actuator stem; and direct acting for rotary valves. Pneumatic operators are simple, dependable, and economical. Molded diaphragms can be used to provide linear performance and increase travel. The sizes of the operators are dictated by the output thrust required and available air pressure supply.

Pneumatic piston operators are operated using high pressure air. The air pressure can be up to 1.03 MPa (150 psig), often eliminating the need for a pressure regulator that is required on a diaphragm actuator. The best design for piston actuators is double acting. This allows for the maximum force in both directions on the piston. Piston actuators can be supplied with accessories

that will position the valve in the event of loss of air supply. These accessories include spring return, pneumatic trip valves, and lock-up type systems. It is common to include manual operators along with pneumatic piston operators in a design. These manual operators can then act as travel stops to limit either full opening or full closing of the valve.

Electric and electro-hydraulic operators are more expensive than pneumatic actuators; however, they offer advantages when no existing air supply source is available, where low ambient temperatures could affect pneumatic supply lines, or where very large stem forces or shaft forces are required. Electrical operators only require electrical power to the motors and electrical input signal from the controller in order to be positioned. Electrical operators are usually self-contained and operate within either a weather-proof or an explosion-proof casing.

An auxiliary positioner or booster is sometimes used on pneumatic operating systems when it is necessary to split the controller output to more than one valve, to amplify the controller above the standard range in order to provide increased actuator thrust, or to provide the best possible control with minimum overshoot and fastest possible recovery following a disturbance or load change. Determination of whether to use a positioner or a booster depends on the speed of the system response. If the system is relatively fast, such as is typical of pressure control and most flow control loops, the proper choice is a booster. If the system is relatively slow, as is typical of liquid level, blending, temperature and reactor control loads, the proper choice is a positioner¹.

Hydraulic snubbers dampen the instability of the valve plug in severe applications and are used on pneumatic piston and direct acting diaphragm actuators.

Limit switches can be used to operate signal lights, solenoid valves, electric relays, or alarms. The limit switches are typically provided with 1 to 6 individual switches and are operated by the movement of the valve stem. It is common for each switch to be individually adjustable and used to indicate the full open or full closed position on a valve.

Electro-pneumatic transducers and electro-pneumatic positioners are used in electronic control loops to position pneumatically operated control valves. The positioner or transducer receives a current input signal and then supplies a proportional pneumatic output signal to the pneumatic actuator to position the valve.

g. Supports

Specific pipe material design recommendations are followed when designing supports for valves. In general, one hanger or other support should be specified for each side of a valve, that is, along the two pipe sections immediately adjacent to the valve. The weight of the valve is included in the calculation of the maximum span of supports.

10-2. Valve Types

The main valve types have many variations and may have different names depending upon manufacturer. Careful selection and detailed specifications are required to insure that design and performance requirements are met.

a. Check Valves

Check valves are self-actuated. These valves are opened, and sustained in the open position, by the force of the liquid velocity pressure. They are closed by the force of gravity or backflow. The seating load and tightness is dependent upon the amount of back pressure. Typical check valves include swing check, tilting disc check, lift check, and stop check. Other check valve types are available, however.

Swing check valves are used to prevent flow reversal in horizontal or vertical upward pipelines (vertical pipes or pipes in any angle from horizontal to vertical with upward flow only). Swing check valves have discs that swing open and closed. The discs are typically designed to close on their own weight, and may be in a state of constant movement if velocity pressure is not sufficient to hold the valve in a wide open position. Premature wear or noisy operation of the swing check valves can be avoided by selecting the correct size on the basis of flow

¹ Fisher Control Company, p. 35.

conditions. The minimum velocity required to hold a swing check valve in the open position is expressed by the empirical formula²:

$$V = j\sqrt{v}$$

where:

V = liquid flow, m/s (ft/s)
 v = specific volume of the liquid, m³/N (ft³/lb)
 j = 133.7 (35) for Y-pattern
 = 229.1 (60) for bolted cap
 = 381.9 (100) for U/L listed

Tilting disc check valves are pivoted circular discs mounted in a cylindrical housing. These check valves have the ability to close rapidly, thereby minimizing slamming and vibrations. Tilting disc checks are used to prevent reversals in horizontal or vertical-up lines similar to swing check valves. The minimum velocity required for holding a tilting check valve wide open can be determined by the empirical formula³:

$$V = j\sqrt{v}$$

where:

V = liquid flow, m/s (ft/s)
 v = specific volume of the liquid, m³/N (ft³/lb)
 j = 305.5 (80) for a 5° disc angle (typical for steel)
 = 114.6 (30) for a 15° disc angle (typical for iron)

Lift check valves also operate automatically by line pressure. They are installed with pressure under the disc. A lift check valve typically has a disc that is free floating and is lifted by the flow. Liquid has an indirect line of flow, so the lift check is restricting the flow. Because of this, lift check valves are similar to globe valves and are generally used as a companion to globe valves. Lift check valves will only operate in horizontal lines. The minimum velocity required to hold a lift check valve open is calculated using the following empirical formula⁴:

$$V = j\beta^2\sqrt{v}$$

where:

V = liquid flow, m/s (ft/s)
 v = specific volume of the liquid, m³/N (ft³/lb)
 j = 152.8 (40) for bolted cap
 = 534.7 (140) for Y-pattern
 β = ratio of port diameter to inside pipe diameter

Stop check valves are typically used in high pressure and hazardous applications. Stop check valves have a floating disc. Sizing of these valves is extremely important because of the floating disc, and manufacturer's recommended procedures should be used. Stop check valves typically have a manual operator and, in this manner, can be forced closed to prevent any backflow of materials. The minimum velocity required for a full disc lift in a stop check valve is estimated by the following empirical formula⁵:

$$V = j\beta^2\sqrt{v}$$

where:

V = liquid flow, m/s (ft/s)
 v = specific volume of the liquid, m³/N (ft³/lb)
 j = 210.0 (55) globe, OS&Y blocked bonnet
 = 286.4 (7S) angle, OS&Y blocked bonnet
 = 229.1 (60) Y-pattern, OS&Y bolted bonnet
 = 534.7 (140) Y-pattern, threaded bonnet
 β = ratio of port diameter to inside pipe diameter

Use of these empirical methods may result in a check valve sized smaller than the piping which is used. If this is the case, reducers are used to decrease pipe size to the smaller valve. The pressure drop is no greater than that of the larger valve that is partially open, and valve life is extended⁶.

² Crane Valves, Engineering Data, p. 53.

³ Ibid., p. 53.

⁴ Ibid., p. 53.

⁵ Ibid., p. 54.

⁶ Crane Valves, Cast Steel Valves, p. 14.

b. Ball Valves

Ball valves with standard materials are low cost, compact, lightweight, easy to install, and easy to operate. They offer full flow with minimum turbulence and can balance or throttle fluids. Typically, ball valves move from closed to full open in a quarter of a turn of the shaft and are, therefore, referred to as quarter turn ball valves. Low torque requirements can permit ball valves to be used in quick manual or automatic operation, and these valves have a long reliable service life. Ball valves can be full ball or other configurations such as V-port.

Full ball valves employ a complete sphere as the flow controlling member. They are of rotary shaft design and include a flow passage. There are many varieties of the full ball valves, and they can be trunion mounted with a single piece ball and shaft to reduce torque requirements and lost motion.

One of the most popular flow controlling members of the throttling-type ball valves is a V-port ball valve. A V-port ball valve utilizes a partial sphere that has a V-shaped notch in it. This notch permits a wide range of service and produces an equal percentage flow characteristic. The straight-forward flow design produces very little pressure drop, and the valve is suited to the control of erosive and viscous fluids or other services that have entrained solids or fibers. The V-port ball remains in contact with the seal, which produces a shearing effect as the ball closes, thus minimizing clogging.

c. Gate Valves

The gate valve is one of the most common valves used in liquid piping. This valve, as a rule, is an isolation valve used to turn on and shut off the flow, isolating either a piece of equipment or a pipeline, as opposed to actually regulating flow. The gate valve has a gate-like disc which operates at a right angle to the flow path. As such, it has a straight through port that results in minimum turbulence erosion and resistance to flow. However, because the gate or the seating is perpendicular to the flow, gate valves are impractical for throttling service and are not used for frequent operation applications.

Repeated closure of a gate valve, or rather movement toward closure of a gate valve, results in high velocity flow. This creates the threat of wire drawing and erosion of seating services. Many gate valves have wedge discs

with matching tapered seats. Therefore, the refacing or repairing of the seating surfaces is not a simple operation. Gate valves should not, therefore, be used frequently to avoid increased maintenance costs. In addition, a slightly open gate valve can cause turbulent flow with vibrating and chattering of the disc.

A gate valve usually requires multiple turns of its hand wheel manual operator in order to be opened fully. The volume of flow through the valve is not in direct proportion to the number of turns of the hand wheel.

d. Globe and Angle Valves

Liquid flow does not pass straight through globe valves. Therefore, it causes an increased resistance to flow and a considerable pressure drop. Angle valves are similar to globe valves; however, the inlet and outlet ports are at 90° angles to one another, rather than at 180° angles. Because of this difference, the angle valves have slightly less resistance to flow than globe valves. However, both valve types operate similarly in principle and, for the purposes of this document, discussion of globe valves will also pertain to angle valves.

There are a number of common globe valve seating types. Table 10-8 presents some of the more common seating types, along with advantages and disadvantages of each.

The seating of the plug in a globe valve is parallel to the line of liquid flow. Because of this seating arrangement, globe valves are very suitable for throttling flow with a minimal seat erosion or threat of wire drawing.

A globe valve opens in direct proportion to the number of turns of its actuator. This feature allows globe valves to closely regulate flow, even with manual operators. For example, if it takes four turns to open a globe valve fully, then approximately one turn of a hand wheel will release about 25% of the flow, two turns will release 50%, and three turns will release 75%. In addition, the shorter travel saves time and work, as well as wear on valve parts.

Maintenance is relatively easy with globe valves. The seats and discs are plugs, and most globe valves can be repaired without actually removing the valve from the pipe.

Table 10-8 Common Globe Valve Seating	
Type	Comments
Plug	Long taper with matching seat provides wide seating contact area. Excellent for severe throttling applications. Resistant to leakage resulting from abrasion. With proper material selection, very effective for resisting erosion.
Conventional Disc	Narrow contact with seat. Good for normal service, but not for severe throttling applications. Subject to erosion and wire drawing. Good seating contact if uniform deposits (such as from coking actions) occur. Non-uniform deposits make tight closure difficult.
Composition Disc	“Soft” discs provided in different material combinations depending upon liquid service. Good for moderate pressure applications except for close throttling, which will rapidly erode the disc.
Needle	Sharp pointed disc with matching seat provides fine control of liquid flow in small-diameter piping. Stem threads are fine, so considerable stem movement is required to open or close.
Source: Compiled by SAIC, 1998	

e. Butterfly Valves

Butterfly valves provide a high capacity with low pressure loss and are durable, efficient, and reliable. The chief advantage of the butterfly valve is its seating surface. The reason for this advantage is that the disc impinges against a resilient liner and provides bubble tightness with very low operating torque. Butterfly valves exhibit an approximately equal percentage of flow characteristic and can be used for throttling service or for on/off control.

Typical butterfly bodies include a wafer design, a lug wafer design (a wafer with the addition of lugs around the bodies), and a flanged design. In all designs, butterfly valves are typically made with standard raised face piping flanges. Butterfly valves are available standard in sizes up to 72 inches for many different applications. The operators can be either pneumatic or electric.

f. Pinch Valves

Pinch valves, as the name suggests, pinch an elastomeric sleeve shut in order to throttle the flow through the pipeline. Because of the streamlined flow path, the pinch valve has very good fluid capacity. Pinch valves typically have a fairly linear characteristic. However, some manufacturers offer field reversible cam-characterizable positioners. These positioners will vary the rate of stem change as a function of position in order to match the flow characteristics desired. In some instances, the cams are set up to provide an equal percentage flow characteristic through a pinch valve.

The pinch valve sleeve is available in various elastomer materials in order to adjust for chemical resistance. In addition, because the throttling takes place in the elastomer sleeve, and elastomers typically have very good abrasion resistance; pinch valves are often used for slurries or liquids that contain high amounts of solids.

g. Plug Valves

Plug valves are another type of isolation valve designed for uses similar to those of gate valves, where quick shutoff is required. They are not generally designed for flow regulation. Plug valves are sometimes also called cock valves. They are typically a quarter turn open and close. Plug valves have the capability of having multiple outlet ports. This is advantageous in that it can simplify piping. Plug valves are available with inlet and outlet ports with four-way multi-port valves which can be used in place of two, three or four straight valves.

h. Self-Contained Automatic Valves

Self-contained automatic valves are used for pressure-reducing stations. The valve body itself is normally a globe-type valve. It is normally diaphragm actuated and hydraulically operated. The valves are capable of maintaining constant downstream pressure regardless of the fluctuations in flow or upstream pressure by internal hydraulic controllers.

10-3. Valve Sizing and Selection

Valve sizing and type selection is a critical component of a piping design. Valve type is shown on P&IDs, and valve size is commonly provided on valve schedules. The sizing and selection procedures are different for non-control and control valves.

a. Non-Control Valves

Non-control valves used for isolation are the same size as the connecting pipe. This sizing reduces pressure loss. Check valves may be smaller than the connecting pipe, provided that the valves are properly sized to ensure full open operation without flow restriction. Materials of construction, wetted or otherwise, and end connections are in compliance with applicable codes and standards and address the fluid application for corrosivity (see Paragraph 10-1).

b. Control Valves

Control valves are sized and selected to optimize application. Valves that are sized too small will not pass

the required flow. Control valves that are sized too large or are arbitrarily sized to match the connecting pipe, will result in increased capital costs, decreased valve life (due to the throttling and erosion effects when operating near to the closed position), and decreased performance (by limiting rangeability). Control valves are optimally selected by identifying the flow characteristic required, then calculating an expected flow coefficient and the maximum allowable pressure drop. These factors are then compared to manufacturers' data for specific valve types and sizes.

To select a control valve, the process application must be understood. Minimum information considered includes desired flow characteristics; type, temperature, viscosity, and specific gravity of the liquid; minimum and maximum flow capacity; minimum and maximum valve inlet pressure; and minimum and maximum valve outlet pressure.

For example, Figure 10-2 depicts a piping system curve, with and without the control valve, and an overlying pump curve. Typically, a valve differential pressure (ΔP) of approximately 33% of the total piping system friction drop at maximum flow is desired (as shown on Figure 10-2). For systems that require low turndown, or face abrasion or other problems, the valve ΔP may be as low as 15%⁷.

Once a desired ΔP is determined, the valve flow coefficient (C_v) and allowable pressure drop (ΔP_{allow}) are calculated for a fully open valve in accordance with the flow chart depicted on Figure 10-3. The valve recovery factor (R_m) and cavitation index (K_c) are determined from manufacturers' data for a specific type and size of valve.

The sizing formulas for incompressible flow without mixed-phase fluids, dense slurries, dry solids or non-Newtonian liquids are as follows⁸:

$$C_v = \frac{Q}{N_1 \sqrt{\frac{s.g.}{\Delta P}}}$$

where:

C_v = valve flow coefficient

Q = flow, m³/hour (gpm)

⁷ Gardellin, p. 4.

⁸ ISA-S75.01, pp. 15-18, 33-35.

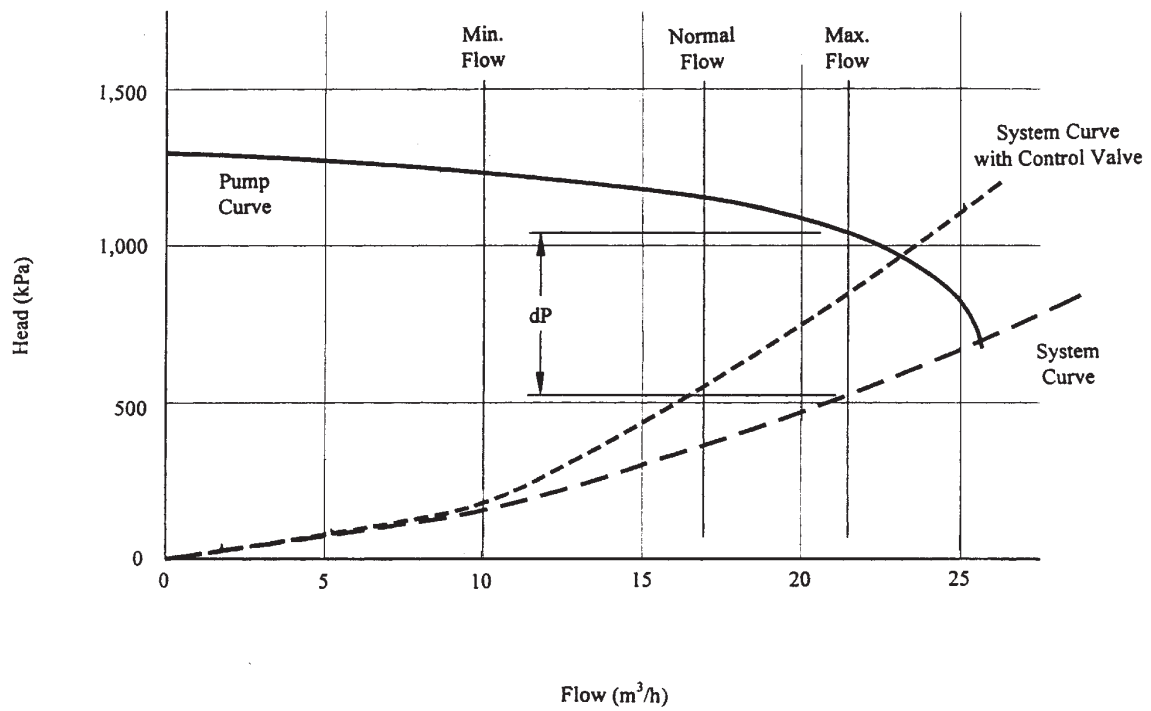

Figure 10-2. Control Valve Pressure Drop Curve
(Source: SAIC, 1998)

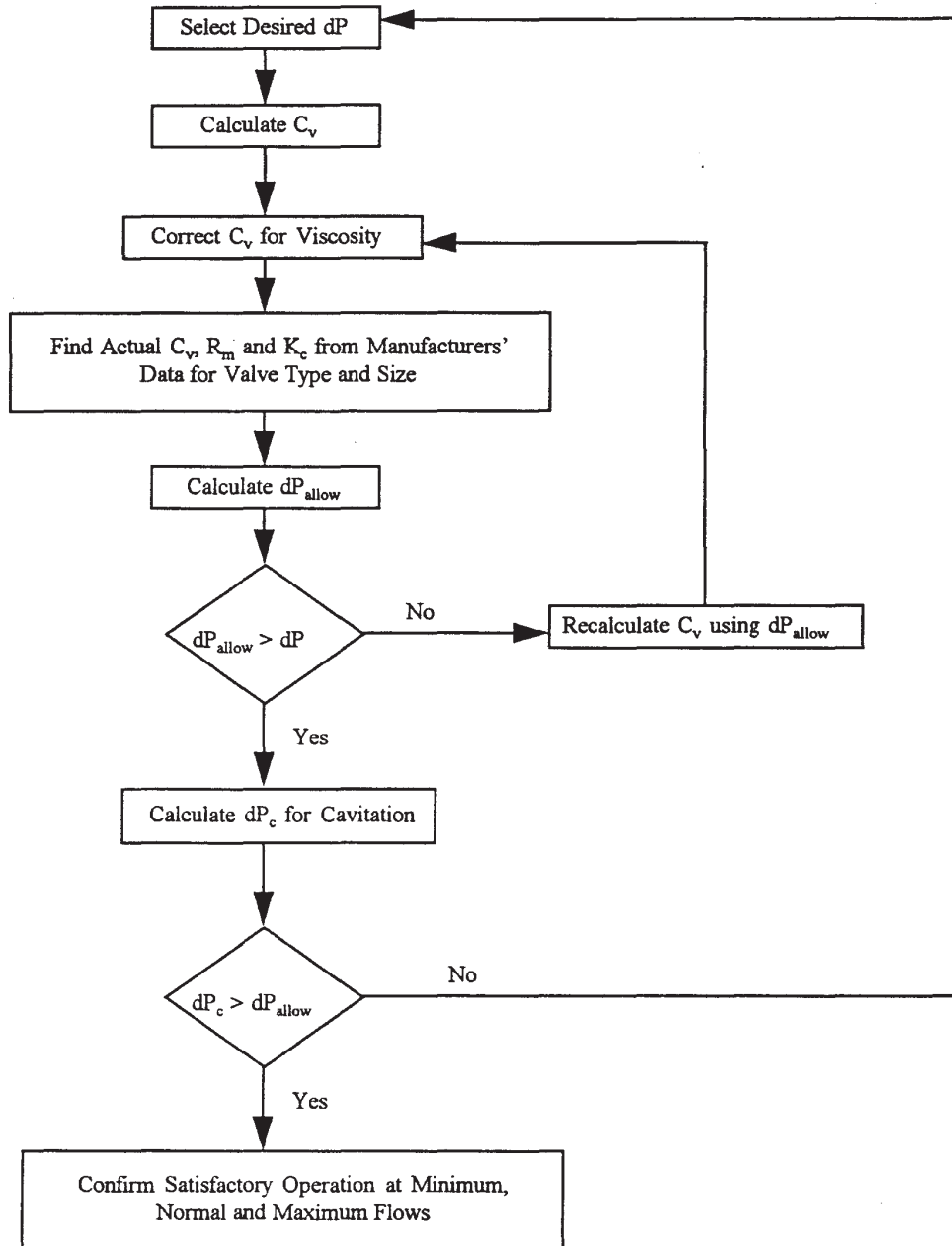

Figure 10-3. Control Valve Sizing
(Source: SAIC, 1998)

N_1 = Conversion factor, 0.085 when Q is in m³/hour and ΔP is in kPa (1.00 when Q is in gpm and ΔP is in psi)

s.g. = specific gravity of liquid

ΔP = differential pressure across valve, kPa (psi)

$$Re_v = \frac{N_4 F_d Q}{v R_m^{1/2} C_v^{1/2}} \left[\frac{R_m^2 C_v^2}{N_2 d^4} + 1 \right]^{1/4}$$

where:

Re_v = valve Reynolds number

N_4 = conversion factor, 76,000 when Q is in m³/hour and d is in mm (17,300 when Q is in gpm and d is in inches)

F_d = valve style modifier, see Table 10-9

Q = volumetric flow rate, m³/hour (gpm)

v = kinematic viscosity, mm²/sec (centistoke)

R_m = valve recovery factor, from manufacturers' data (see Table 10-9)

C_v = valve flow coefficient

N_2 = conversion factor, 0.00214 when d is in mm (890 when d is in inches)

d = valve inlet diameter, mm (in)

$$C_{vc} = \frac{C_v}{F_R}$$

where:

C_{vc} = valve flow coefficient corrected for viscosity

F_R = valve Reynolds number factor (see Figure 10-4)

$$\Delta P_{allow} = R_m^2 (P_i - r_c P_v)$$

where:

ΔP_{allow} = maximum valve ΔP to avoid choked flow, kPa (psi)

R_m = valve recovery factor, from manufacturers' data (see Table 10-9)

P_i = valve inlet pressure, kPa (psi)

r_c = critical pressure ratio, calculation as follows or see Figure 10-5

P_v = liquid vapor pressure, kPa (psia)

$$r_c = 0.96 - 0.28 \left(\frac{P_v}{P_c} \right)^{1/2}$$

where:

r_c = critical pressure ratio

P_v = liquid vapor pressure, kPa (psi)

P_c = absolute thermodynamic critical pressure, kPa (psi)

$$\Delta P_c = K_c (P_i - P_v)$$

where:

ΔP_c = valve ΔP at which cavitation damage occurs, kPa (psi)

K_c = cavitation index, from manufacturers' data

P_i = valve inlet pressure, kPa (psi)

P_v = liquid vapor pressure, kPa (psi)

Example Problem 8:

Figure 10-2 represents the process to be controlled and control valve is for flow control purposes with an orifice plate flow measurement device. The liquid is water with trace hydrocarbons. The pipe size is 100 mm and the operating conditions are: T = 15.6°C; P_i = 517 kPa, 172.4 kPa, and 1030 kPa for normal, minimum, and maximum operating conditions, respectively.

Solution:

Step 1. From Figure 10-2, ΔP at max. flow = 496 kPa and Q = 17 m³/hour normal

10 m³/hour minimum

21.5 m³/hour maximum

Step 2. The flow measurement device is proportional to flow squared so that an equal percentage for characteristic is desired. Assume a butterfly valve will be used so F_d = 0.7, and R_m = 0.7 (from Table 10-9)

Step 3. From common fluid mechanics reference materials: s.g. = 1.0; P_v = 1.85 kPa; P_c = 22.09 MPa; v = 1.13 mm²/sec.

Step 4. Therefore, the valve calculations are:

TABLE 10-9 Example Values of Valve Capacity Factors					
Valve Type	Trim Type	Flow Direction*	R _m	F _d **	C _v /d ^{2***}
Globe - Single port	Ported plug	Either	0.9	1.0	6,129 (9.5)
	Contoured plug	Open	0.9	1.0	7,098 (11)
		Close	0.8	1.0	7,098 (11)
	Characterized cage	Open	0.9	1.0	9,032 (14)
		Close	0.85	1.0	10,322 (16)
Wing guided	Either	0.9	1.0	7,098 (11)	
- Double port	Ported plug	Either	0.9	0.7	8,065 (12.5)
	Contoured plug	Either	0.85	0.7	8,387 (13)
	Wing guided	Either	0.9	0.7	9,032 (14)
- Rotary	Eccentric Spherical plug	Open	0.85	1.0	7,742 (12)
		Close	0.68	1.0	8,710 (13.5)
Angle	Contoured plug	Open	0.9	1.0	10,968 (17)
		Close	0.8	1.0	12,903 (20)
	Characterized cage	Open	0.85	1.0	7,742 (12)
		Close	0.8	1.0	7,742 (12)
	Venturi	Close	0.5	1.0	14,194 (22)
Ball	Segmented	Open	0.6	1.0	16,129 (25)
	Standard port (diameter ≈ 0.8d)	Either	0.55	1.0	14,194 (22)
Butterfly	60-Degree aligned	Either	0.68	0.7	11,290 (17.5)
	Fluted vane	Either	0.7	0.7	16,129 (25)
	90-Degree offset seat	Either	0.60	0.7	18,710 (29)
* Flow direction tends to open or close the valve: i.e., push the closure member away from or towards the seat.					
** In general, an F _d value of 1.0 can be used for valves with a single flow passage. An F _d value of 0.7 can be used for valves with two flow passages, such as double-ported globe valves and butterfly valves.					
*** In this table, d may be taken as the nominal valve size, mm (in).					
NOTE: The values are typical only for the types of valves shown at their rated travel for full-size trim. Significant variations in value may occur because of any of the following reasons: reduced travel, trim type, reduced port size, and valve manufacturer.					
Source: ISA -S75.01, p. 31; Copyrighted material reprinted by permission of the Instrument Society of America, all rights reserved.					

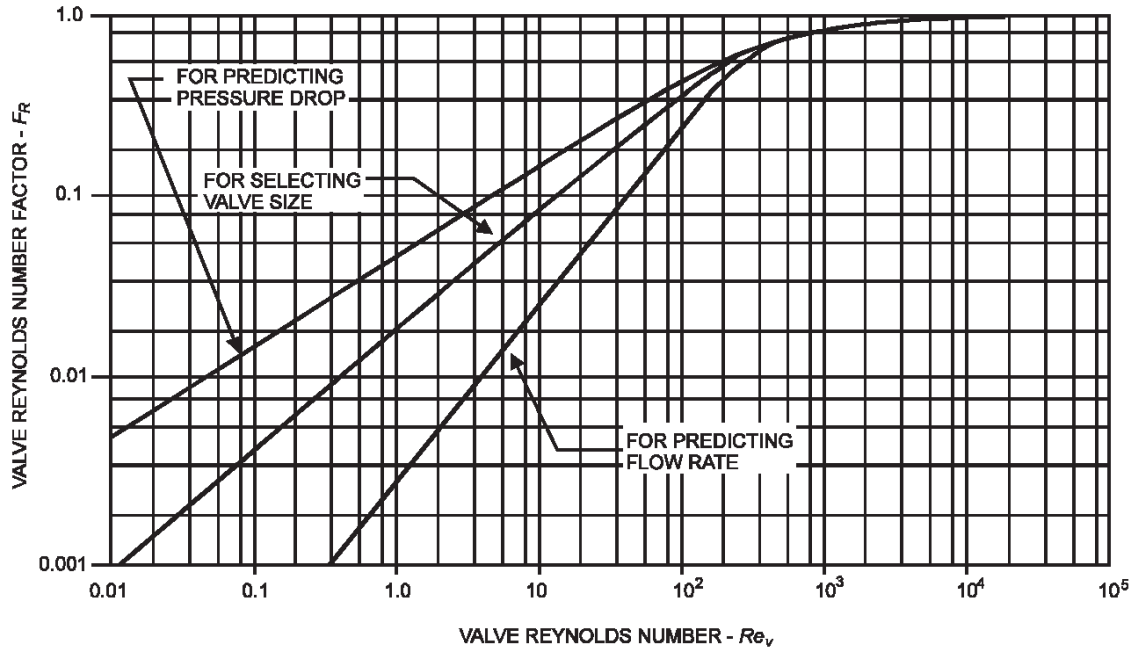
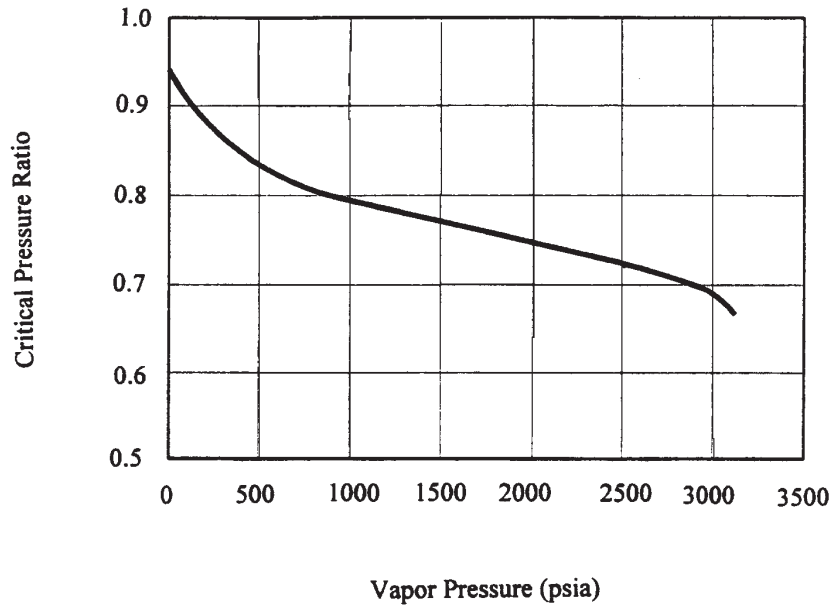
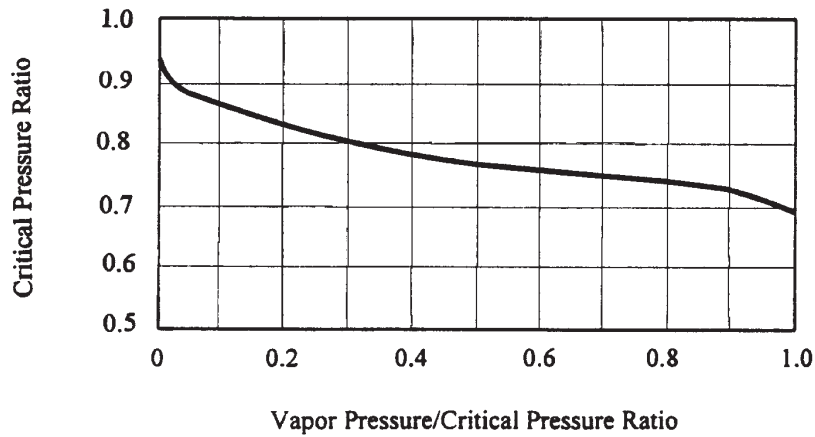

Figure 10-4. Valve Factor Diagram
(Source: ISA-S75.01-1985 (R 1995), p. 34.)



a. Curve to be Used for Water



b. Curve for Liquids Other Than Water

Figure 10-5. Critical Pressure Ratio
(Source: Fisher, *Control Valve Handbook*, 2nd Ed., p. 67)

$$C_v = \frac{Q}{N_1} \sqrt{\frac{s.g.}{\Delta P}}$$

$$C_v = \frac{21.5 \text{ m}^3/\text{hour}}{0.085} \sqrt{\frac{1.0}{496 \text{ kPa}}} = 11.4$$

$$Re_v = \frac{N_4 F_d Q}{v R_m^{1/2} C_v^{1/2}} \left[\frac{R_m^2 C_v^2}{N_2 d^4} + 1 \right]^{1/4}$$

$$Re_v = \frac{(76,000)(0.7)(21.5)}{(1.13)(0.7)^{1/2}(11.4)^{1/2}} \left[\frac{(0.7)^2(11.4)^2}{(0.00214)(100)^4} + 1 \right]^{1/4}$$

$$Re_v = 3.57 \times 10^5$$

$F_R = 1.0$ from Figure 10-4 (a viscosity correction is not required due to the high Reynolds number). Therefore, $C_{vc} = 11.4$.

Step 5. From manufacturer's data, a 25 mm, 60° V-port ball valve at full open in a 50 mm pipe has a C_v of 11.2 and a R_m of 0.75. Therefore, neck the connecting piping down to 50 mm, and select a 25 mm V-port ball valve (has an equal percentage flow characteristic).

Step 6. The allowable pressure drop of the system is compared to the actual valve differential pressure to confirm that the valve will operate satisfactorily.

$$r_c = 0.96 - 0.28 \left(\frac{P_v}{P_c} \right)^{1/2}$$

$$= 0.96 - 0.28 \left(\frac{1.85 \text{ kPa}}{22,090 \text{ kPa}} \right)^{1/2}$$

$$r_c = 0.96$$

$$\Delta P_{allow} = R_m^2 (P_i - r_c P_v)$$

$$= (0.75)^2 [1030 \text{ kPa} - (0.96)(1.85 \text{ kPa})]$$

$$\Delta P_{allow} = 578 \text{ kPa at max. flow (full open)}$$

$\Delta P_{allow} \geq \Delta P$ at maximum flow, therefore, the valve is acceptable.

10-4. Valve Schedule

Many manufacturers have PC-based sizing programs that will size and select their optimum valve for a specific application. In addition, computerized piping system design programs may also have valve sizing and selection routines that will select the optimum valve in their databases. Although these sizing programs can provide useful data, the optimum valve for a particular application may be found elsewhere. For design purposes, contract drawings include a valve schedule to aid in the bidding and proper supply of valves.

a. Valve Schedule

Table 10-10 presents a valve schedule that is included in the contract drawings for liquid process piping design.

b. Valve Operators Schedule

Table 10-11 is a valve operator schedule that is sometimes included in the contract drawings. This schedule is used when additional information, beyond that shown on a valve schedule, is required.

**Table 10-10
Valve Schedule**

Valve Tag/Ref	Description	Size Range	Flange Rating	Screwed Ends	Design Rating	Body Materials	Trim Materials	Bolting Materials	Operation	Service	Remarks
V120	Ball Valve, Full Port Positive Shut-off	50 mm & Smaller	--	Taper ANSI B2.1	1.39 MPa	316 SS	316 SS Ball & Stem Glass Filled TFE Seats, TFE Seals	--	Lever	IWW, SLG, WPS	
V121	Ball Valve, Full Port Positive Shut-off	80 mm	ANSI B16.5 Class 150	--	689 kPa	316 SS	316 SS Ball & Stem Glass Filled TFE Seats, TFE Seals	CS ASTM A 307 Gr B	Lever	SW, ALT, RO, AL, SWW, RL	Instrument Isolation Valves Only
V122	Ball Valve, Full Port Positive Shut-off	40 mm & Smaller	ANSI B16.5 Class 300	--	1.03 MPa	316 SS	316 SS Ball & Stem Glass Filled TFE Seats, TFE Seals	CS ASTM A 307 Gr B	Lever	WCR	
V123	Solid Wedge Gate Valve O.S. & Y., Rising Stem	50 mm & Larger	ANSI B16.5 Class 300	--	1.03 MPa	CS ASTM A 216 GR WCB	13% Cr Steel Seats & SS Stem	CS ASTM A 307 Gr B	Handwheel	SLP	
V124	Double Disc Gate Valve O.S. & Y., Rising Stem	50 mm & Larger	ANSI B16.5 Class 150	--	689 kPa	CS ASTM A 216 GR WCB	UT Trim 316 SS Stem	CS ASTM A 307 Gr B	Handwheel	SL	
V150	Swing Check Valve	50 mm to 300 mm	ANSI B16.5 Class 150	--	689 kPa	CS ASTM A 216 GR WCB	13% Cr Steel Seats & Disc	CS ASTM A 307 Gr B	--	XLT, ALT, RL, AL, SLO, PLO	All Drain Points to be Threaded & Plugged
V151	Swing Check Valve	50 mm & Smaller	--	Taper ANSI B2.1	1.39 MPa	Bronze	Bronze	--	--	PW	All Drain Points to be Threaded & Plugged
V152	Y-Pattern Check Valve	50 mm & Smaller	--	Socket Weld	17.2 MPa	CS ASTM A 105	13% Cr Steel Seats & 302 SS Spring	--	--	FWH	
V153	Lined Wafer Check Valve	250 mm	Fit Between Class 150	--	689 kPa	PFA Coated CS	PFA Coated Steel	--	--	DWH	
V154	Wafer Style Check Valve	100 mm to 250 mm	Fit Between Class 150	--	689 kPa	410 SS ASTM A 276	302 SS	--	--	AP	All Drain Points to be Threaded & Plugged
PCV-452	Globe Valve, Bolted Bonnet, O.S. & Y., Rising Stem	100 mm	ANSI B16.5 Class 150	--	689 kPa	CS ASTM A 216 GR WCB	SS	CS ASTM A 307 Gr B	Pneumatic Diaphragm R.A.	RCY	
FCV-501	Butterfly Valve	100 mm	Fit Between Class 150	--	689 kPa	PFA Lined D.I.	PFA Lined D.I. & SS Stem	--	Electric	AG, AV	
FCV-625	Butterfly Valve	300 mm	Fit Between Class 150	--	689 kPa	PFA Lined CS	PTFE Lined CS & SS Stem	--	Electric, Enclosed Gear	DWH	

Source: Example Schedule by SAIC, 1998.

Table 10-11
Valve Operator Schedule

Operator Tag/Ref	Description	Type	Maximum Air Pressure	Electrical Supply	Action	Materials of Construction	Failure Mode	Enclosure Rating	Accessories	Associated Valve	Remarks
V120	Ball Valve, Full Port Positive Shut-off	Pneumatic, Diaphragm	1.03 MPa	--	R.A.	Manufacturer's Standard with Epoxy Coating	F.O.	Weather Proof	Positioner, Filter/Regulator, Handwheel	PCV-452	
V121	Ball Valve, Full Port Positive Shut-off	Pneumatic, Piston	1.03 MPa	--	D.A.	Manufacturer's Standard with Epoxy Coating	F.C.	Weather Proof	Positioner, Filter, Handwheel	PCV-1013	
V122	Ball Valve, Full Port Positive Shut-off	Pneumatic, Rotary	1.03 MPa	--	D.A.	Aluminum	F.L.	NEMA 4	I/P, Filter	FCV-485	
V123	Solid Wedge Gate Valve O.S. & Y., Rising Stem	Electric, Rotary	--	120 V, 20 A, 1 ph	D.A.	Manufacturer's Standard with Epoxy Coating	F.L.	NEMA 4		FCV-501	
V124	Double Disc Gate Valve O.S. & Y., Rising Stem	Electric, Rotary	--	120 V, 20 A, 1 ph	D.A.	Manufacturer's Standard	F.C.	NEMA 4X	Enclosed Gear,	FCV-625	

Source: Example Schedule by SAIC, 1998.

Chapter 11 Ancillary Equipment

11-1. Flexible Couplings

Flexible couplings are used to join pipe sections, to insulate sections from one other, to absorb concentrated pipe movement, and to join plain end pipe to flanged valves and other equipment. The basic purpose of flexible couplings is to provide flexible but leak-tight connections that will last for the life of the piping. Flexible couplings are generally available in sizes from 15 mm (½ in) to 1.8 m (6 feet) and larger.

a. Metallic Flexible Couplings

The basic configuration of a flexible coupling is a metallic middle ring that slips over the joint between two pipe sections with a gasket and a follower at each end. This configuration compresses the gasket and seals the middle ring (see Figure 11-1). The middle ring can be provided standard in a number of different materials, such as plastic or rubber lined, stainless steel, aluminum, Monel, carbon steel, and ductile iron (see Appendix B for the proper material and contact the manufacturers to determine availability). The gaskets are likewise available in different materials (typically, elastomers and rubber materials).

b. Transition Couplings

Similar to flexible couplings in construction, transition couplings connect pipe with a small difference in outside diameter: the middle ring in transition couplings is pre-deflected to adjust for the differences in diameter. As with the flexible couplings, the transitional coupling's middle ring and gaskets are available in different materials, depending upon the application.

c. Flanged Couplings

Flanged couplings are typically provided with a compression end connection on one end and a flange on the other. The flanges can be provided in different ANSI or AWWA standards, as required for the application. The manufacturer should be consulted for pressure ratings.

d. Couplings for Non-metallic Piping

Flexible couplings for non-metallic piping are very similar to metallic piping couplings. There are three main configuration alternatives for these couplings. The first is the same configuration as the metallic piping, in which there is a middle ring that is sealed by gaskets and held in place with end pieces that are bolted together. The second method is very similar, except that the end pieces are lock rings, similar to compression fittings, threaded to hold the middle ring in place. In both instances, the wetted-parts materials are selected in order to meet the application. The last type of typical flexible coupling for non-metallic piping is a bellows expansion joint (see Paragraph 11-8c). The bellows expansion joints can accommodate directional changes of compression/extension and lateral offset and angular rotation of the connected piping; however, these joints are not capable of absorbing torsional movement. If a bellows expansion joint is used as a flexible connector, a minimum of two corrugations should be provided. The potential movement of the bellows is calculated to obtain the proper number of corrugations.

11-2. Air and Vacuum Relief

During startup, shutdown and in normal operations, it is common for liquid process piping system to produce situations where air needs to be exhausted or allowed to re-enter. The devices used include air-release valves, air-vacuum valves, vacuum breakers, and combination air-release and air-vacuum valves. The type of valve required varies for the specific applications.

a. Air-release Valves

For liquid process piping in which air tends to collect within the lines (as occurs under pressure systems as air dissolves and then reappears as the pressure decreases), air-release valves are necessary. A very common operating problem occurs when air collects in the high places of the piping systems, producing air pockets. These air pockets can reduce the effective area of the pipe through which the liquid can flow, causing a problem known as air binding. Air binding results in pressure loss, thus increasing pumping costs.

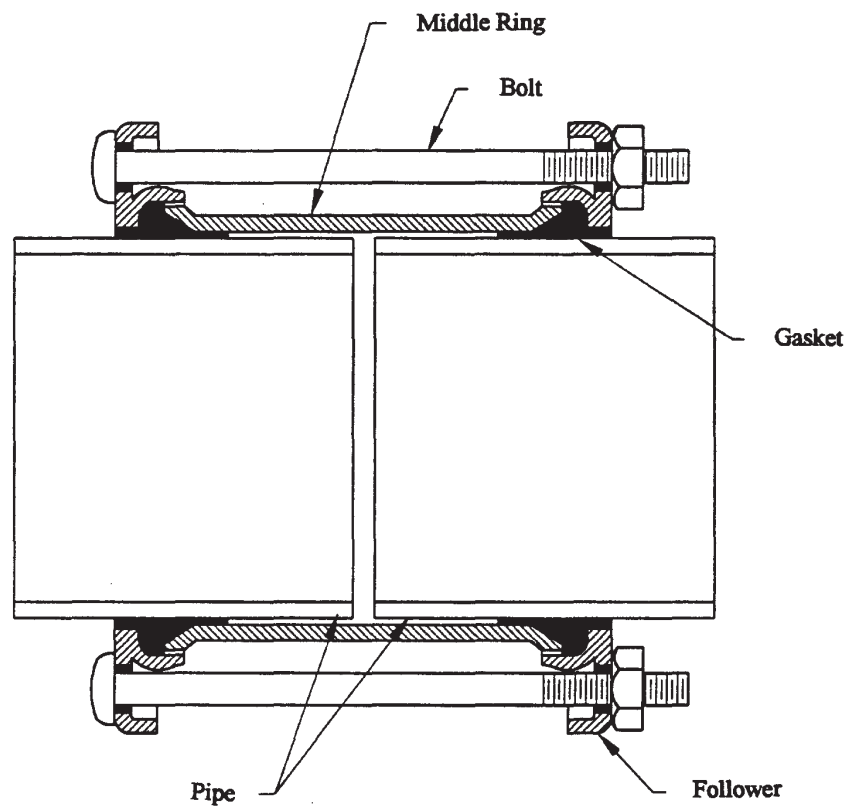

Figure 11-1. Flexible Coupling
(Source: Dresser Industries, Inc., "Style 38 Dresser Couplings for Steel
Pipe Sizes, Sizes and Specifications," Form 877-C Rev. 1095)

It is typical for air-release valves to be installed to eliminate these problems. Air-release valves should be installed at pumping stations where air can enter the system, as well as at all high points in the pipeline system where air can collect. Air-release valves automatically vent any air that accumulates in the piping system while the system is in operation and under pressure. However, the potential for accumulating hazardous gases must be taken into account, and the vents located in a manner such that it does not cause a hazardous atmosphere for the operators. Air-release valves do not provide vacuum protection nor vent large quantities of air as required on pipeline filling; air-vacuum valves are designed for these purposes.

The sizing of air-release valves is based upon engineering judgement and experience. The parameters which affect valve size are the potential for air entrainment, pipe diameter, volumetric flow rate, system pressure, fluid viscosity, surface condition of the pipe wall, and the degree of pipe slope adjacent to the piping high point. Manufacturers' data can assist in the selection.

b. Air-Vacuum Valves

For piping systems that are used intermittently and are therefore periodically filled and drained, air-vacuum valves are used to prevent damage to the piping system. The damage could result from over-pressurization and velocity surges during filling, or collapse during draining.

Air-vacuum valves are installed at piping high points. These valves are float operated, have large discharge and inlet ports that are equal in size, and automatically allow large volumes of air to be rapidly exhausted from or admitted into a pipeline. As with air-release valves, the potential for releasing hazardous gases must be addressed in the design and the vents located to permit a hazard condition for personnel. Air-vacuum valves will not vent gases when the piping system is in normal operation and under pressure. Air-release valves are designed for that purpose.

The sizing of air-vacuum valves is performed independently for each location and requires the review of both functions; i.e., air exhaust and air intake. The largest valve required for either function is selected. The flow capacity required is compared to manufacturers' data relating acceptable pressure drop to valve size. The flow capacity requirements are determined as follows:

$$Q_{\text{exhaust}} = Q_{\text{max}}$$

where:

$$Q_{\text{exhaust}} = \text{volumetric flow rate of exhaust air, m}^3/\text{s (ft}^3/\text{s)}$$

$$Q_{\text{max}} = \text{maximum liquid filling rate, m}^3/\text{s (ft}^3/\text{s)}$$

$$Q_{\text{intake}} = Q_{\text{gravity}}$$

where:

$$Q_{\text{intake}} = \text{volumetric flow rate of intake air, m}^3/\text{s (ft}^3/\text{s)}$$

$$Q_{\text{gravity}} = \text{gravity flow rate of liquid during draining, m}^3/\text{s (ft}^3/\text{s)}$$

c. Vacuum Breakers

Two primary types of vacuum breakers are available -- atmospheric and pressure. Atmospheric vacuum breakers operate in the event of total pressure loss. Pressure vacuum breakers provide protection against back siphonage and pressure surges. The configuration of pressure vacuum breakers vary by manufacturer. The configuration used to prevent back siphonage of hazardous liquids often involves a check valve as well as an air intake.

Figure 11-2 depicts a combination pressure vacuum breaker and its typical installation requirements. The pressure vacuum breaker is a spring-loaded check valve that opens during forward flow and is closed by the spring when the flow stops. When the pressure drops to a low value, a second valve will open and allow air to enter the breaker.

The configuration used for applications that may involve pressure surges have associated air-release valves. The latter arrangement allows the large volumes of air, admitted by the vacuum breaker, to be slowly exhausted by the air-release valve under operating conditions and act as a pressure surge reservoir.

d. Combination Air-release and Air-Vacuum Valves

The operating functions of both an air-release valve and an air-vacuum valve are accommodated in a single combination air-release and air-vacuum valve. Using this type of valve in lieu of air-release and air-vacuum valves

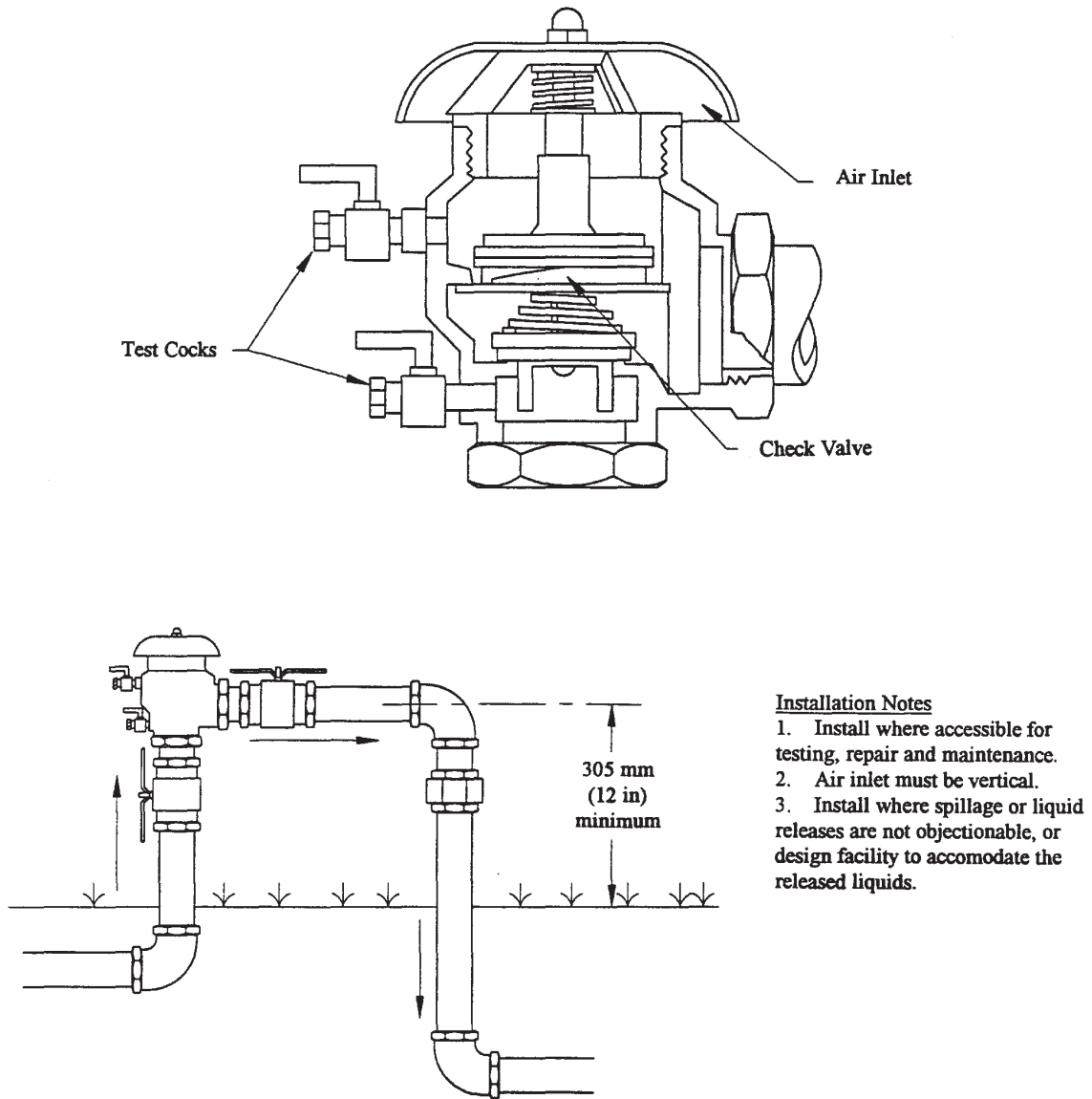

Figure 11-2. Pressure and Vacuum Breaker
(Source: FEBCO, Service Information Model 765 Pressure
Vacuum Breaker Assembly, vendor bulletin Oct 89)

typically provides the piping system with maximum protection. However, each individual location should be carefully reviewed.

e. Air and Vacuum Relief Application

Suggested application of air and vacuum relief devices into the piping design is as follows:

- Locate air-vacuum valves at all system high points where the piping system will be likely used intermittently. For non-hazardous service with continuous operations, manual valves or other methods may be more cost effective.
- Locate combination air-release and air-vacuum valves at all system high points where the potential for air accumulation exists.
- Locate air-release valves at intervals of 500 to 850 m (1,640 to 2,790 ft) on long horizontal pipe runs lacking a clearly defined high point. Air-release valves are installed with an isolation valve, typically a full port ball valve, between the air-release valve and the piping system for maintenance purposes.
- Locate vacuum breakers on closed vessels.

11-3. Drains

All low points in liquid process piping systems should be provided with drain or blow-off valves. These valves allow flushing of sediments from, or draining of, the entire lines. The most common valves used for draining purposes are gate valves. If rapid draining is not important, globe valves may also be used, provided that sediment accumulation is not a concern. Pipelines 50 mm (2 in) and smaller should use 15 mm (½ in) valves, as a minimum size. Pipelines that are 65 mm (2½ in) or greater should have a minimum valve size of 20 mm (¾ in).

11-4. Sample Ports

Materials of construction for sample ports and sample valves match the piping system and the required application. Coordination with CEGS 01450, Chemical Data Quality Control, is necessary to ensure proper sampling.

a. Port Locations

Sample piping should be as short as possible, protected from physical damage, and easily accessed by operators. Sample connections are made on feed, intermediate and product streams for process control. Process engineers are consulted in order to determine the number and location of sample ports.

b. Design Requirements

It is recommended that the minimum size connection to either the process equipment or the piping be 15 mm (¾ in). If the sample line is longer than a meter (approximately 3 feet), two valves are installed in the sample line. The first valve is located as close to the actual sample point as possible. The second valve is a final block valve and should be located near the end of the sample piping. The valves should be quick opening, either gate or ball type, and all materials of construction should meet the application.

11-5. Pressure Relief Devices

The ASME B31 Pressure Piping Code provides the standards and requirements for pressure relief devices and systems including piping downstream of pressure relief devices. Table 11-1 provides a summary of the relief pressure limits, but these limits shall not be used without consulting the proper ASME B31 section. Note that high pressure piping is not included.

a. Pressure Relief Valves

Pressure relief valves are automatic pressure relieving devices that protect piping systems and process equipment. The valves protect systems by releasing excess pressure. During normal operation, the valve disc is held against the valve seat by a spring. The spring is adjustable to the pressure at which the disc lifts. The valve disc lift is proportional to the system pressure so that, as the system pressure increases, the force exerted by the liquid on the disc forces the disc up and relieves the pressure. The valve will reseal when the pressure is reduced below the set spring pressure. Pressure relief valve materials and process pressure range must be accounted for to specify the correct pressure relief device.

**Table 11-1
Summary of Pressure Device Limits**

Service	Relief Set Limit	Code Reference
Metallic Piping - Category D Service*	≤ 120% design pressure	ASME B31.3 - 322.6
Nonmetallic Piping - Category D Service	= design pressure	ASME B31.3 - A322.6
Metallic Piping - Category M Service**	≤ 110% design pressure	ASME B31.3 - M322.6
Nonmetallic Piping - Category M Service	= design pressure	ASME B31.3 - MA322.6

Notes: *Category D Service is a fluid service in which the fluid handled is non-flammable, nontoxic and not damaging to human tissues; the design pressure does not exceed 1.035 MPa (psig); and the design temperature is from -29°C (-20°F) to 186°C (366°F). (ASME B31.3, p. 5.)
**Category M Service is a fluid service in which the potential for personnel exposure is judged to be significant and in which a single exposure to a very small quantity of a toxic fluid, caused by leakage, can produce serious irreversible harm to persons on breathing or bodily contact, even when prompt restorative measures are taken. (ASME B31.3, p. 5.)
Source: ASME B31.3, Reprinted by permission of ASME.

b. Rupture Discs

A rupture disc is another form of a pressure relief device. Rupture discs are designed to rupture automatically at a predetermined pressure and will not reclose. These discs can relieve very large volumes of liquid in a rapid manner. Materials of construction include metals, graphite or plastic materials held between special flanges and of such a thickness, diameter and shape, and material, that it will rupture at a pre-determined pressure. There are also metal rupture discs coated with plastics. In addition, for highly corrosive service, precious metals such as silver, gold, and platinum are also used.

Pressure relief valves and rupture discs may be used in series. In such cases, rupture discs are designed to rupture at a pressure approximately 5 to 10% above the pressure at which a relief valve is designed to activate. In this manner, the rupture disc acts as a backup device. It can be used upstream of a safety relief device to protect the valve components from corrosion or malfunction due to process materials. Rupture discs are occasionally placed downstream of relief valves in manifolded relief

discharge systems where it is necessary to protect the discharge side of the pressure relief valve from corrosion. Gate valves (but not safety valves) may also be placed in front of rupture discs, allowing for shutoff or maintenance of the discs. Discs usually require periodic replacement as operating experience and conditions dictate.

Rupture disc sizing is based on the premise that, if adequate flow is allowed from the disc, pressure will be relieved. Rupture discs are not intended to be explosion relief devices. The following sizing equation is derived from Bernoulli's equation and the conservation of momentum, and can be used for liquid service. The equation assumes that the disc vents immediately to atmosphere (no relief piping) and that nozzle friction losses are negligible. Use of this equation complies with ASME B31 requirements, but its use should be reviewed with respect to local pressure vessel codes¹.

$$A = n \frac{Q}{K} \sqrt{\frac{s.g.}{P_r}}$$

¹ Fike Metal Products, Rupture Discs & Explosion Protection, p. 9.

where:

- A = required rupture disc area, mm² (in²)
- n = conversion coefficient, 2.280 x 10⁴ for SI units and 0.0263 for IP units.
- Q = flow, m³/s (gpm)
- K = flow coefficient (K = 0.62 per ASME B31)
- s.g. = specific gravity
- P_r = relieving pressure, MPa (psi)

Example Problem 9:

Assume that a toxic liquid with a specific gravity of 1.04 is flowing at a rate of 0.050 m³/s (800 gpm) through stainless steel piping that has a maximum working pressure rating of 2.207 MPa (300 psi). A rupture disc will be used as the primary relief device.

Solution:

Step 1. In accordance with ASME B31.3, a primary pressure relief device should not exceed 10% over maximum allowable working pressure.

$$P_r = (2.17 \text{ MPa})(110\%) = 2.39 \text{ MPa} \text{ (330 psig)}$$

Step 2.

$$A = (2.280 \times 10^4) \left(\frac{0.05 \text{ m}^3/\text{s}}{0.62} \right) \sqrt{\frac{1.04}{2.39 \text{ MPa}}}$$

$$= 1,213 \text{ mm}^2 \text{ (1.88 in}^2\text{)}$$

$$A = \frac{\pi D_i^2}{4} \Rightarrow D_i = \left(\frac{4A}{\pi} \right)^{0.5}$$

$$D_i = 39.3 \text{ mm (1.55 in), minimum}$$

Therefore, from Table 1-1 (page 1-2), the bore diameter of the pressure relief disc is 40 mm (1 1/2 in).

c. Safety Considerations

The use of pressure relief devices requires careful material selection and determination of activation pressure. In addition, the design includes means to collect the released liquid once it leaves the pipeline to protect the operators and the environment.

11-6. Backflow Prevention

Backflow prevention is often handled by three main methods, one of which is check valves which were discussed in Chapter 10. Another method is the use of pressure and vacuum breakers, which were discussed in Paragraph 11-2. The third method is use of a reduced pressure backflow prevention assembly.

a. Reduced Pressure Backflow Prevention

Reduced pressure backflow prevention assemblies are mandatory for the mechanical protection of potable water against the hazards of cross-connection contamination. Whenever the potential exists for hazardous materials to come in contact with potable waters, reduced pressure backflow prevention assemblies are required per AWWA standards.

The reduced pressure backflow prevention assembly typically has two Y-type check valves in series, in between which is located an internal relief valve. In a flow condition, the check valves are open with a liquid pressure that is typically about 35 kPa (5.0 psi) lower than the inlet pressure. If flow or reversal of flow occurs, the relief valve, which activates on a differential pressure measurement, will open and discharge in order to maintain the zone between the check valves at least 14 kPa (2 psi) lower than the supply pressure. When normal flow resumes, the relief valve closes as the differential pressure resumes. The relief valve discharge is potentially hazardous material. The design of a facility takes that potential discharge into account.

Reduced pressure backflow prevention assemblies are used in different configurations. In one standard configuration, the inlet and outlet are in line. Another common configuration is an angle pattern in which the inlet to the assembly is vertical up and the outlet is vertical down.

b. Installation

Reduced pressure backflow prevention assemblies are installed, or designed to be installed, with a minimum of clearance of 305 mm (12 in) between the discharge port of the relief valve and the floor grade. The assemblies

need to be installed in a location where testing and maintenance can be performed. Situations that could result in excessive pressure are eliminated. These situations include thermal water expansion and/or water hammer. Local plumbing codes are reviewed for specific installation requirements. Some codes prohibit vertical installation. Materials of construction are typically limited. Reduced pressure backflow prevention assemblies are normally used for potable water applications. Typical characteristics and materials of construction for the assemblies are presented in Table 11-2.

11-7. Static Mixers

Static mixers provide a means of in-line rapid mixing for chemical addition or the combination of two liquid streams. As opposed to conventional rapid mixers, such as turbines and hydraulic jumps, static mixers have no moving parts. This characteristic makes the static mixer a low maintenance alternative for rapid mixing.

a. Design Requirements

Static mixers are generally customized to meet the requirements of each application. Five parameters are

evaluated in the design of a static mixer system: the materials of construction, the size of the pipe, the head loss requirements for the mixer, the number of mixing elements, and the quality of mixing to be achieved.

b. Materials of Construction

Common materials used for static mixers include stainless steel, carbon steel, polyvinyl chloride (PVC), reinforced fiberglass, polytetrafluoroethylene (PTFE) and polyvinylidene fluoride (PVDF). The materials available are dependent upon the manufacturer, and some manufacturers offer additional material options for specific applications.

In choosing the appropriate materials, the requirements of both the static mixer's housing and the mixing elements are accommodated. By combining materials, one can produce a static mixer which provides both chemical resistance and structural strength to the static mixer housing and mixing elements. See Appendix B for material compatibility with fluids.

Static mixers are commonly built from standard diameter piping. Available pipe diameters vary by manufacturer; however, common pipe diameters start at 20 mm (¾ in).

Table 11-2 Typical Reduced Pressure Backflow Prevention Assembly	
Characteristic/Parts	Rating/Material
Assembly Body	Bronze, ASTM B 584-78
Relief Valve Body	Bronze, ASTM B 584-78
Seat Disc	Nitrile, ASTM D 2000 or Silicone
Diaphragm	Nitrile, fabric reinforced
Springs	SS, 300 series options
End Connections	Threaded, ASME B1.20.1
Maximum Working Pressure	1.2 MPa (175 psi)
Fluid Temperature Range	0°C to 60°C (32°F to 140°F)
Source: CMB Industries, FEBCO Backflow Prevention, Reduce Pressure Assembly for High Hazard Service, Model 825Y, vendor bulletin.	

c. Pressure Loss

The end connections available for static mixers include ends prepared for welding, threaded NPT ends, and flanged ends of various classes. Both the pipe diameter and end connections are typically designed to match the process piping system used. However, the diameter of mixer housing can be sized based on the pressure drop available, or desired, if the application requires.

Whereas mechanical mixers require energy to drive the mixing motor, static mixers obtain their required energy the velocity of the fluids being mixed. Thus, every static mixer will have a resulting pressure drop. The pressure drop through the static mixer is dependent upon the flow rate through the static mixer, the specific gravity and viscosity of the fluids being mixed, the diameter of the mixer housing, and the friction loss attributable to the mixing elements. Each manufacturer has sizing equations and/or flow coefficients that are specific for their product. Although the sizing calculations are reviewed to ensure that correct parameter values are used, the specifications place performance requirements on the mixer manufacturer.

d. Configuration

The number of mixing elements effects the quality of mixing achieved, the length of the mixer, and the head loss requirements of the mixer. Factors which affect the number of mixing elements required include the flow regime, the difference in viscosities of the fluids being mixed, the volumetric ratio of the fluids being mixed, the method of injection, and the miscibility of the fluids. Different manufacturers produce mixing elements in different configurations. The different element configurations produce varying mixing results, and estimates on the number of elements required are best obtained by contacting the static mixer manufacturer.

The quality of mixing achieved by a static mixer is often discussed in terms of homogeneity. Homogeneity refers to how closely the combined fluid resembles a homogeneous mixture after passing through a static mixer. Homogeneity is often expressed as a percentage standard deviation from the mean, and is determined by sampling for the desired mixing parameter (concentration, temperature, conductivity) and determining the mean and standard deviation of the samples. Required homogeneity is application specific,

and manufacturers can best determine the number of mixing elements required to achieve the desired homogeneity.

Additional considerations for the design of a static mixer include the number and location of injection ports and the method of chemical injection. The location, connection type and size of injection ports can be customized to match each application. Several types of injection quills are available, as options and specifications vary from manufacturer to manufacturer. It is advisable to contact static mixer manufacturers to determine what selections may suit the desired application and the reasons for recommendation of those options. The contract drawings and specifications are then coordinated to reflect acceptable alternatives.

11-8. Expansion Joints

Expansion joints are used to absorb pipeline expansion typically resulting from thermal extensions. The use of expansion joints is often required where expansion loops are undesirable or impractical. However, expansion joints are not used for direct buried service. Expansion joints are available slip-type, ball, and bellows configurations.

a. Slip-Type Expansion Joints

Slip-type expansion joints have a sleeve that telescopes into the body. Leakage is controlled by packing located between the sleeve and the body. Because packing is used, a leak-free seal is not assured. Properly specified, these expansion joints do not leak; however, because packing is used, these expansion joints should not be used where zero leakage is required. Occasional maintenance is required to repair, replace, and replenish the packing. Slip-type joints are particularly suited for axial movements of large magnitude. They cannot, however, tolerate lateral offset or angular rotation due to potential binding. Therefore, pipe alignment guides are necessary with slip-type expansion joints.

b. Ball Expansion Joints

Ball expansion joints consist of a socket and a ball, with seals placed in between the two parts. Ball expansion joints can handle angular and axial rotation; however, they cannot tolerate axial movements.

c. Bellows Expansion Joints

Bellows expansion joints can be metallic or rubber in material of construction. They do not have packing. These joints typically have bellows, or corrugations, that expand or contract as required to absorb piping expansion. End connections can be welded and/or flanged. Bellows expansion joints can adjust to lateral offset and angular rotation as well as to axial movements. However, they are not capable of handling torsional movement. In order to provide this flexibility, metal bellows are typically much thinner than the associated piping and are subject to over-pressure failure. Metal fatigue due to the cyclic life of the bellows is another factor that must be included in the design.

For example, a typical method to select and size a bellows expansion joint is as follows:

Step 1. Determine the basic type required by the piping system:

- standard without reinforced corrugations (non-equalizing);
- standard with reinforced corrugations (equalizing rings);
- hinged (single plane angular movement only);
- gimbal (multiple plane angular movement only);
- tied (lateral movement only);
- balanced (axial and lateral movement only);
- or other.

Step 2. Determine the body requirements of the expansion joint:

- maximum system pressure and temperature;
- internal diameter equal to the inner diameter of the pipe (D_i);
- end connections (flanged, welded end, combinations, or other);
- material of construction for bellows and sleeves, if required (select material based on application, see Appendix B and Table 11-3, Material Temperature Ranges);
- external body cover, if required (damage protection, insulation application).

Step 3. Calculate the maximum movements (contraction and expansion) to be absorbed by the expansion joint (see previous chapters for thermal expansion).

Step 4. Determine the expansion joint performance requirements and the required bellows configuration:

- calculate the required cycle life, for example, assume a process is anticipated to undergo 2 on-off cycles per week and a 10 year process life is desired

$$\left(\frac{2 \text{ process cycles}}{\text{week}} \right) \left(\frac{52 \text{ weeks}}{\text{year}} \right) (10 \text{ years})$$

$$= 1,040 \text{ cycles required}$$

(note that a manufacturer's standard warranty is 2,000 cycles for axial movement with cycle life is increased to 7,000 if the expansion joint sized for movement = 75% expansion joint rating²);

- select the number of corrugations from manufacturers' data (function of corrugation size, wall thickness, amount of movement, and design cycle life, see Table 11-4);

- determine whether an internal sleeve is required. Sleeves are recommended when

D ≤ 150 mm (6 in) and V > 0.02 m/s per mm diameter (1.66 ft/s per inch diameter), and when

D > 150mm (6 in) and V > 3 m/s (10 ft/s);

where:

D = nominal pipe size, mm (in)

V = fluid velocity, m/s (ft/s).³

11-9. Piping Insulation

Liquid process piping often has to be insulated when potential heat loss from piping cannot be tolerated in the process, freezing potential exists, or protection of personnel from hot piping is required. CECS 15080, Thermal Insulation for Mechanical Systems, is used for engineering information and construction requirements.

² ADSCO Manufacturing LLC, Expansion Joints Cat. 1196.

³ Ibid.

Table 11-3 Material Temperature Ranges	
Material	Acceptable Temperature Range
304 Stainless Steel	-185 °C to 815 °C (-300 °F to 1,500 °F)
316 Stainless Steel	-185 °C to 815 °C (-300 °F to 1,500 °F)
321 Stainless Steel	-185 °C to 815 °C (-300 °F to 1,500 °F)
347 Stainless Steel	-185 °C to 815 °C (-300 °F to 1,500 °F)
Aluminum	-198 °C to 204 °C (-325 °F to 400 °F)
Nickel 200	-156 °C to 315 °C (-250 °F to 600 °F)
Inconel 600	-156 °C to 649 °C (-250 °F to 1,200 °F)
Inconel 625	-156 °C to 649 °C (-250 °F to 1,200 °F)
Monel 400	-156 °C to 815 °C (-250 °F to 1,500 °F)
Incoloy 800	-156 °C to 815 °C (-250 °F to 1,500 °F)
Incoloy 825	-156 °C to 538 °C (-250 °F to 1,000 °F)
Source: ADSCO Manufacturing LLC, Expansion Joints Cat 1196	

Table 11-4 Typical Manufacturers' Data List		
Size, in	Number of Convolutions	Total Axial Movement, in
4	1	7/16
	2	7/8
	3	1-5/16
	4	1-3/4
	5	2-3/16
	6	2-5/8
	7	3-1/16
	8	3-1/2
	9	3-15/16
	10	4-3/8
Source: ADSCO Manufacturing LLC, Expansion Joints Cat. 1196		

In addition, the specification provides guidance on insulation thickness based on pipe size, insulation thermal conductivity or material, and range of temperature service. CEGS 15080 is coordinated with the liquid process piping specification section and contract drawings.

11-10. Heat Tracing

For the purposes of liquid process piping, heat tracing is the continuous or intermittent application of heat to the piping system, including pipe and associated equipment, to replace heat loss. As with insulation, heat tracing is used when potential heat loss from the piping cannot be tolerated by the process or when freezing potential exists. Heat tracing may be accomplished through the use of fluids such as steam, organic/synthetic liquids, and glycol mixtures, or through electrical systems such as self-regulating parallel resistance cable (most common), zone parallel resistance cable, continuous-wattage cables and other methods.

a. Heat Tracing System Selection

The selection criteria for determining the most suitable heat tracing methods include: cost, availability of utilities such as steam or electricity, amount of heat to be provided, area hazardous classification as defined by the National Electric Code (NFPA 70), temperature control requirements and consequence of failure. Economics generally favor electrical heat tracing systems when the piping is less than 300 mm (12 in) in diameter and the temperature to be maintained is 120°C (248°F) or lower. Computer programs are available to assist in selecting the type of system that is most appropriate. In addition, many heat tracing vendors have software available to design a heat tracing system using their products. Typical inputs are piping size and geometry; ambient, process and desired maintenance temperature; control requirements; labor costs and utility rates. Outputs are typically worst case heat loss; a bill of materials for the heat tracing system; and capital, installation and operating costs.

Chapter 12 Corrosion Protection

12-1. Corrosion Protection

Among other factors, the integrity and life of a piping system is dependent upon corrosion control. As discussed in previous chapters of this manual, internal corrosion of piping systems is controlled by the selection of appropriate materials of construction, wall thickness, linings and by the addition of treatment chemicals. External corrosion can also be addressed through materials of construction. However, other methods may be required when metallic piping systems are applied.

a. Buried Installations

In buried installations, leaks due to corrosion in metallic piping systems can cause environmental damage. Furthermore, certain types of processes pose safety problems if cathodic protection is not properly installed and maintained. The design and installation of the piping system without consideration of cathodic protection is not acceptable.

b. Above Grade Installations

The external surfaces of metallic piping installed above grade will also exhibit electrochemical corrosion. The corrosion rate in air is controlled by the development of surface-insoluble films. This development is, in turn, affected by the presence of moisture, particulates, sulfur compounds, nitrogen-based compounds, and salt. This corrosion is typically uniform, although pitting and crevice corrosion are also common. Besides selecting a material of construction that is appropriate for the ambient environment, the primary method of corrosion control in above grade piping system is the application of protective coatings. However, a stray current survey must be performed to ensure that electrical currents have not been created through the piping support system.

12-2 Cathodic Protection

Cathodic protection and protective coatings shall both be provided for the following buried/submerged ferrous metallic structures, regardless of soil or water resistivity:

- natural gas propane piping;
- liquid fuel piping;
- oxygen piping;
- underground storage tanks;
- fire protection piping;
- ductile iron pressurized piping under floor (slab on grade) in soil;
- underground heat distribution and chilled water piping in ferrous metallic conduit in soils with resistivity of 30,000 ohm-cm or less; and
- other structures with hazardous products as identified by the user of the facility.

a. Cathodic Protection Requirements

The results of an economic analysis and the recommendation by a "corrosion expert" shall govern the application of cathodic protection and protective coatings for buried piping systems, regardless of soil resistivity. In addition, cathodic protection for metallic piping supported above ground may be warranted. TM 5-811-7, Electrical Design, Cathodic Protection, provides criteria for the design of cathodic protection for aboveground, buried, and submerged metallic structures including piping. Cathodic protection is mandatory for underground gas distribution lines, 946 m³ (250,000 gal) or greater water storage tanks and underground piping systems located within 3 m (10 ft) of steel reinforced concrete.¹

For ductile iron piping systems, the results of an analysis by a "corrosion expert," as defined in Paragraph 12-2b, shall govern the application of cathodic protection and/or bonded and unbonded coatings. Unbonded coatings are defined in AWWA C105.

¹ TM 5-811-7, p. 2-2.

b. Cathodic Protection Designer

All pre-design surveys, cathodic protection designs, and acceptance surveys must be performed by a "corrosion expert." A corrosion expert is defined as a person who, by reason of thorough knowledge of the physical sciences and the principles of engineering and mathematics acquired by a professional education and related practical experience, is qualified to engage in the practice of corrosion control of buried or submerged metallic piping and tank systems. Such a person must be accredited or certified by the National Association of Corrosion Engineers (NACE) as a NACE Accredited Corrosion Specialist, or a NACE Certified Cathodic Protection Specialist licensing that includes education and experience in corrosion control of buried or submerged metallic piping and tank systems. The "corrosion expert" designing the system must have a minimum of five years experience in the design of cathodic protection systems, and the design experience must be type specific. For instance, a cathodic protection engineer who only has experience designing water tank systems should not design the cathodic protection system for an underground gas line.

The design of the cathodic protection system shall be completed prior to construction contract advertisement except for design-construct projects and pre-approved underground distribution systems. The liquid process piping specification section shall be coordinated with CEGS 13110, Cathodic Protection System (Sacrificial Anode); CEGS 13111, Cathodic Protection System (Steel Water Tanks); and CEGS 13112, Cathodic Protection System (Impressed Current) as required.

c. Cathodic Protection Methods

As previously discussed, galvanic corrosion is an electrochemical process in which a current leaves the pipe at the anode site, passes through an electrolyte, and re-enters the pipe at the cathode site. Cathodic protection reduces corrosion by minimizing the difference in potential between the anode and cathode. The two main types of cathodic protection systems, galvanic (or sacrificial) and impressed current, are depicted in Figure 12-1. A galvanic system makes use of the different corrosive potentials that are exhibited by different materials, whereas an external current is applied in an impressed current system. The difference between the

two methods is that the galvanic system relies on the difference in potential between the anode and the pipe, and the impressed current system uses an external power source to drive the electrical cell.

d. Cathodic Protection Design

The design of a cathodic protection system must conform to the guidance contained in TM 5-811-7 (Army), and MIL-HDBK-1004/10 (Air Force). Field surveys and other information gathering procedures are available in TM 5-811-7. The following steps and information is required to ensure a cathodic protection system will perform as designed:

Step 1. Collect data:

- corrosion history of similar piping in the area;
- drawings;
- tests to include current requirement, potential survey, and soil resistivity survey;
- life of structures to be protected;
- coatings; and
- short circuits.

Step 2. Calculate the surface area to be protected and determine the current requirement.

Step 3. Select the anode type and calculate the number of anodes required.

Step 4. Calculate circuit resistance, required voltage, and current.

Step 5. Prepare life cycle cost analyses.

Step 6. Prepare plans and specifications.

12-3. Isolation Joints

When piping components, such as pipe segments, fittings, valves or other equipment, of dissimilar materials are connected, an electrical insulator must be used between the components to eliminate electrical current flow. Complete prevention of metal-to-metal contact must be achieved. Specification is made for dielectric unions between threaded dissimilar metallic components; isolation flanged joints between non-threaded dissimilar metallic components; flexible (sleeve-type) couplings for

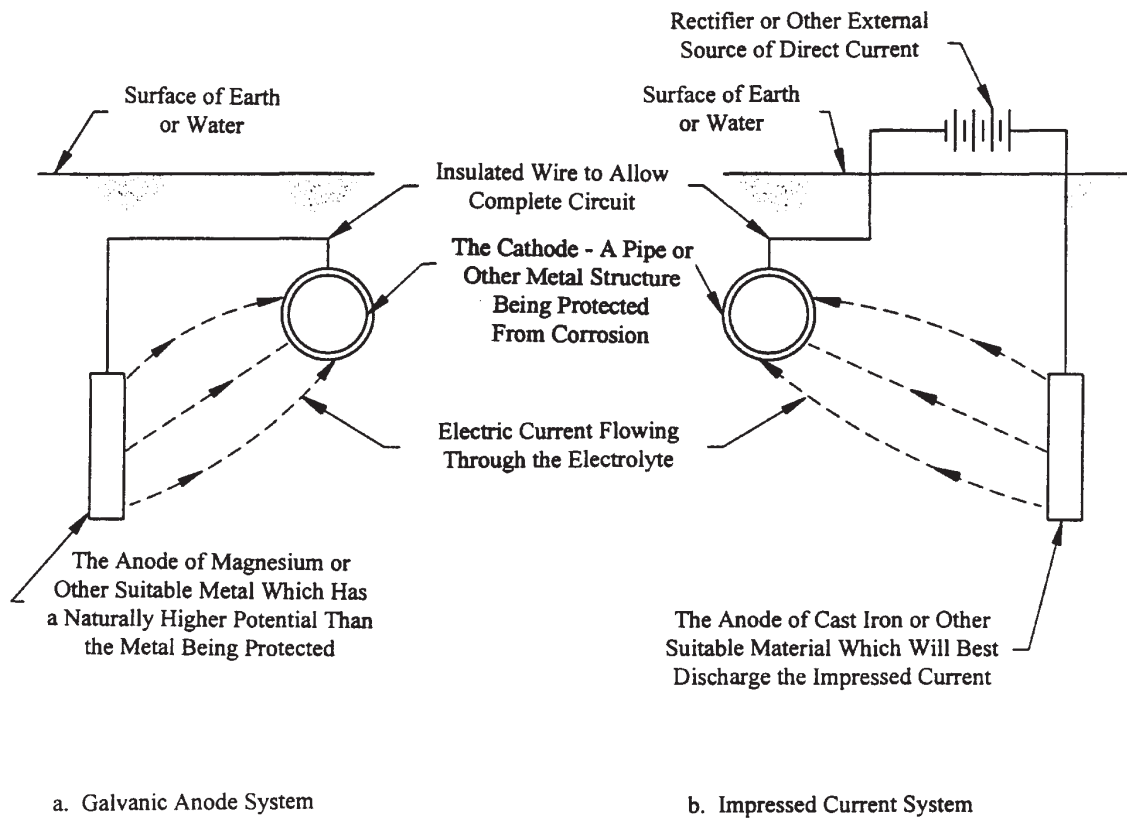

Figure 12-1. Cathodic Protection Methods
(Source: U.S. Air Force)

plain end pipe sections, see Chapter 11 for further information concerning these couplings; and under special aboveground situations that have USACE approval split-sleeve couplings. For the flanged isolation joints complete isolation is required; additional non-metallic bolt isolation washers, and full length bolt isolation sleeves are required. Dielectric isolation shall conform to NACE RP-0286. Copper water service lines will be dielectrically isolated from ferrous pipe.

a. Installation

Proper installation of isolation joints is critical. Installation procedures should follow the manufacturer's recommendations exactly.

b. Isolation from Concrete

A ferrous metallic pipe passing through concrete shall not be in contact with the concrete. The ferrous metal pipe shall be separated by a non-metallic sleeve with waterproof dielectric insulation between the pipe and the sleeve. Ferrous metal piping passing through a concrete thrust block or concrete anchor block shall be insulated from the concrete or cathodically protected.

c. Surge Protection

The need for surge and fault current protection at isolating devices (dielectrically insulated flanges) should be considered. If an insulated flange is installed in an area classified by National Fire Protection Association (NFPA) criteria, such as a flammable liquid pipe joint inside the classified area, a sealed, weatherproof surge arrester must be installed across each isolating device. The arrester should be the gapless, self-healing, solid state type, such as metal oxide varistor. Cable connections from arresters to isolating devices should be short, direct, and a size suitable for short-term, high current loading.

12-4. Protective Coatings

Since corrosion of metallic piping is electrochemical, if a protective coating that is continuous, impervious and insulating is applied to the piping exterior, the electrical circuit cannot be completed, and corrosion will not occur. The bases of selection for an exterior pipe coating are chemical inertness, adhesiveness, electrical resistance, imperviousness, and flexibility to adjust to both pipe

deformation (for example, thermal expansion/contraction) and environmentally induced stress (for example, wind induced shear). Obviously, the coating must be applied without holidays and remain undamaged, without cracks or pinholes.

**Appendix A
References**

A-1. U.S. Army Corps of Engineers (CEGS, EM, TM, etc.)

TM 5-805-4
Noise and Vibration Control

TM 5-809-10
Seismic Design for Buildings

TM 5-810-5
Plumbing

TM 5-811-7
Electrical Design, Cathodic Protection

TM 5-813-9
Water Supply: Pumping Stations

MIL-HDBK-1004/10 (Air Force)
Electrical Engineering, Cathodic Protection

ER 1110-1-4
Metric Measurements in USACE Publication Media

ER 1110-1-12
Quality Management

ER 1110-345-700
Design Analysis, Drawings and Specifications

EM 385-1-1
Safety and Health Requirements Manual

EM 1110-2-503
Design of Small Water Systems

TI 809-01
Load Assumptions for Buildings

TI 814-01
Water Supply

TI 814-03
Water Distribution

TI 814-10
Wastewater Collection

CEGS 02150
Piping: Off-Gas

CEGS 05093
Welding Pressure Piping

CEGS 09900
Painting, General

CEGS 11145
Aviation Fueling Systems

CEGS 13080
Seismic Protection for Mechanical, Electrical
Equipment

CEGS 13110
Cathodic Protection system (Sacrificial Anode)

CEGS 13111
Cathodic Protection system (Steel Water Tanks)

CEGS 13112
Cathodic Protection system (Impressed Current)

CEGS 15080
Thermal Insulation for Mechanical Systems

CEGS 15200
Liquid Process Piping

**A-2. Industrial and Commercial References
(NFPA, ASTM, ANSI, ASME, etc.)**

a. American Association of State Highway and
Transportation Officials

AASHTO H20
Highway Design Standards

b. American National Standards Institute

ANSI A13.1
Scheme for the Identification of Piping Systems

ANSI A58.1 Minimum Design Loads for Buildings and Other Structures

ANSI B36.10M/B36.10 Welded and Seamless Wrought Steel Pipe

c. American Petroleum Institute

API Spec 5L
Line Pipe

API Spec 15LR
Low Pressure Fiberglass Line Pipe

API 605
Large Diameter Carbon Steel Flanges

d. American Society of Civil Engineers

ASCE 7
Minimum Design Loads for Buildings and Other Structures

e. American Society of Mechanical Engineers

ASME Boiler and Pressure Vessel Code
Sections IV, V, VIII

ASME B1.1
Unified Screw Threads

ASME B1.20.1
Pipe Threads, General Purpose

ASME B16.1
Cast Iron Pipe Flanges and Flanged Fittings

ASME B16.5
Pipe Flanges and Flanged Fittings

ASME B16.9
Factory-Made Wrought Steel Butt welding Fittings

ASME B16.11
Forged Fittings, Socket-Welding and Threaded

ASME B16.20
Metallic Gaskets for Pipe Flanges

ASME B16.21
Nonmetallic Gaskets for Pipe Flanges

ASME B16.24
Cast Copper Alloy Pipe Flanges and Flanged Fittings

ASME B16.25
Butt welding Ends

ASME B16.28
Wrought steel Butt welding Short Radius Elbows and Returns

ASME B16.31
Non-Ferrous Pipe Flanges

ASME B16.42
Ductile Iron Pipe Flanges and Flanged Fittings

ASME B16.47
Large Diameter Steel Flanges

ASME B31.1
Power Piping

ASME B31.3
Chemical Plant and Petroleum Refinery Piping

f. American Society for Testing and Materials

ASTM A 47M/A 47
Malleable Iron Castings

ASTM A 53
Pipe, Steel, Black and Hot-Dipped, Zinc Coated
Welded and Seamless

ASTM A 105M/A 105
Carbon Steel Forgings

ASTM A 106
Seamless Carbon Steel Pipe

ASTM A 126
Gray Iron Castings for Valves, Flanges, and Pipe
Fittings

ASTM A 135
Electric-Resistance-Welded Steel Pipe

ASTM A 182M/A 182
Forged or Rolled Alloy-Steel Pipe Flanges, Forged
Fittings, and Valves and Parts

ASTM A 193M/A 193
Alloy-Steel and Stainless Steel Bolting Materials

ASTM A 194M/A 194
Carbon and Alloy Steel Nuts for Bolts for
High-Pressure and High-Temperature Service.

ASTM A 216M/A 216
Steel Castings, Carbon, for High Temperature Service

ASTM A 217M/A 217
Steel Castings, Martensitic Stainless Steel and Alloys,
for High Temperature Service

ASTM A 307
Carbon Steel Bolts and Studs, 60,000 PSI Tensile
Strength

ASTM A 312M/A 312
Seamless and Welded Austenitic Stainless Steel Pipes

ASTM A 333M/A 333
Seamless and Welded Steel pipe for Low-Temperature
Service

ASTM A 351M/A 351
Castings, Austenitic, Austenitic-Ferric

ASTM A 403M/A 403
Wrought Austenitic Stainless Steel Piping Fittings

ASTM A 494
Castings, Nickel and Nickel Alloy.

ASTM A 587
Electric-Resistance-Welded Low-Carbon Steel Pipe

ASTM A 691
Carbon and Alloy Steel Pipe, EFW for High-Pressure
Service at High Temperatures

ASTM A 727M/a 727
Carbon Steel Forgings for Piping Components

ASTM A 731M/A 731
Seamless, Welded Ferritic, and Martensitic Stainless
Steel Pipe

ASTM A 813M/A 813
Single- or Double-Welded Austenitic Stainless Steel
Pipe

ASTM A 814M/A 814
Cold-Worked Welded Austenitic Stainless Steel Pipe

ASTM A 815M/A 815
Wrought Ferritic, Ferritic/Austenitic, and Martensitic
Stainless Steel Piping Fittings

ASTM A 858M/A 858
Heat-Treated Carbon Steel Fittings

ASTM B 42
Seamless Copper Pipe, Standard Sizes

ASTM B 61
Steam or Valve Bronze Castings

ASTM B 62
Composition Bronze or Ounce Metal Castings

ASTM B 160
Nickel Rod and Bar

ASTM B 161
Nickel Seamless Pipe and Tube

ASTM B 165
Nickel-Copper Alloy (N04400) Seamless Pipe and
Tube

ASTM B 241M/B 241
Aluminum and Aluminum-Alloy Seamless Pipe and
Seamless Extruded Tube

ASTM B 247M/B 247
Aluminum and Aluminum-Alloy Die Forgings, Hand
Forgings, and Rolled Ring Forgings

ASTM B 345M/B 345
Aluminum and Aluminum-Alloy Seamless Pipe and
Seamless Extruded Tube for Gas and Oil Transmission
and Distribution Piping Systems

ASTM B 361 Factory-Made Wrought Aluminum and Aluminum-Alloy Welding Fittings

ASTM B 366 Factory-Made Wrought Nickel and Nickel Alloy Fittings

ASTM B 517 Welded Nickel-Chromium-Iron Alloy (N06600), N06025, N06045 Pipe

ASTM B 564
Nickel Alloy Forgings

ASTM B 584 Copper Alloy Sand Castings for General Applications

ASTM B 608
Welded Copper-Alloy Pipe

ASTM B 619 Welded Nickel and Nickel-Cobalt Alloy Pipe

ASTM B 622 Seamless Nickel and Nickel-Cobalt Alloy Pipe and Tube

ASTM B 725 Welded Nickel (N02200/N02201) and Nickel-Copper Alloy (N04400) Pipe

ASTM B 775 General Requirements for Nickel and Nickel Alloy Welded Pipe

ASTM B 829 General Requirements for Nickel and Nickel Alloys Seamless Pipe and Tube

ASTM D 380
Test Methods for Rubber Hose

ASTM D 471 Test Method for Rubber Property-Effect of Liquids

ASTM D 729 Vinylidene Chloride Molding Compounds

ASTM D 1457
Polytetrafluoroethylene (PTFE) Molding and Extrusion Materials

ASTM D 1600
Terminology for Abbreviated Terms relating to Plastics

ASTM D 2000
Standard Classification for Rubber Products in Automotive Applications

ASTM D 2282
Acrylonitrile-Butadiene-Styrene (ABS) Plastic Pipe (SDR-PR)

ASTM D 2310
Standard Classification for Machine-Made "Fiberglass" (Glass-Fiber-Reinforced Thermosetting-Resin) Pipe

ASTM D 2464
Threaded Poly(Vinyl Chloride) (PVC) Plastic Pipe Fittings, Schedule 80

ASTM D 2466
Poly(Vinyl Chloride) (PVC) Plastic Pipe Fittings, Schedule 40

ASTM D 2467
Socket-Type Poly(Vinyl Chloride) (PVC) Plastic Pipe Fittings, Schedule 80

ASTM D 2657
Heat-Joining Polyolefin Pipe and Fittings

ASTM D 2661
Acrylonitrile-Butadiene-Styrene (ABS) Schedule 40 Plastic Drain, Waste and Vent Pipe

ASTM D 2855
Making Solvent-Cemented Joints with Poly(Vinyl Chloride) (PVC) Pipe and Fittings

ASTM D 2996
Filament-Wound "Fiberglass" (Glass-Fiber-Reinforced Thermosetting Resin) Pipe

ASTM D 2997
Centrifugally Cast "Fiberglass" (Glass-Fiber-Reinforced Thermosetting Resin) Pipe

ASTM D 3139
Joints for Plastic Pressure Pipes using Flexible
Elastomeric Seals

ASTM D 3222
Unmodified Poly (Vinylidene Fluoride) (PVDF)
Molding, Extrusion and Coating Materials

ASTM D 3307
PFA-Fluorocarbon Molding and Extrusion Materials

ASTM D 3311
Drain, Waste, and Vent (DWV) Plastic Fittings
Patterns

ASTM D 3517
"Fiberglass" (Glass-Fiber-Reinforced Thermosetting
Resin) Pressure Pipe

ASTM D 3754
"Fiberglass" (Glass-Fiber-Reinforced Thermosetting
Resin) Sewer and Industrial Pressure Pipe

ASTM D 4000
Classification System for Specifying Plastic Materials

ASTM D 4024
Machine Made "Fiberglass" (Glass-Fiber-Reinforced
Thermosetting Resin) Flanges

ASTM D 4101
Propylene Plastic Injection and Extrusion Materials

ASTM D 4161
"Fiberglass" (Glass-Fiber-Reinforced Thermosetting
Resin) Pipe Joints Using Flexible Elastomeric Seals

ASTM E 814
Fire Tests of Through-Penetration Fire Stops

ASTM F 423
Polytetrafluoroethylene (PTFE) Plastic-Lined Ferrous
Metal Pipe, Fittings, and Flanges

ASTM F 437
Threaded Chlorinated Poly(Vinyl Chloride) (CPVC)
Plastic Pipe Fittings, Schedule 80

ASTM F 438
Socket-Type Chlorinated Poly(Vinyl Chloride)
(CPVC) Plastic Pipe Fittings, Schedule 40

ASTM F 439
Socket-Type Chlorinated Poly(Vinyl Chloride)
(CPVC) Plastic Pipe Fittings, Schedule 80

ASTM F 491
Poly (Vinylidene Fluoride) (PVDF) Plastic-Lined
Ferrous Metal Pipe and Fittings

ASTM F 492
Propylene and Polypropylene (PP) Plastic Lined
Ferrous Metal Pipe and Fittings

ASTM F 599
Poly (Vinylidene Chloride) (PVDC) Plastic-Lined
Ferrous Metal Pipe and Fittings

ASTM F 628
Acrylonitrile-Butadiene-Styrene (ABS) Schedule 40
Plastic Drain, Waste and Vent Pipe with a Cellular
Core

ASTM F 781
Perfluoro (Alkoxyalkane) Copolymer (PFA) Plastic-
Lined Ferrous Metal Pipe and Fittings

ASTM F 1173
Epoxy Resin Fiberglass Pipe and Fittings for Marine
Applications

ASTM F 1290
Electrofusion Joining Polyolefin Pipe and Fittings

g. American Water Works Association

AWWA C105
Polyethylene Encasement for Ductile-Iron Pipe
Systems

AWWA C110
Ductile-Iron and Gray-Iron Fittings

AWWA C150
Thickness Design of Ductile-Iron Pipe

AWWA C900
Polyvinyl Chloride (PVC) Pressure Pipe

AWWA C950
Fiberglass Pressure Pipe

AWWA D103
Factory-Coated Bolted Steel Tanks for Water Storage

AWWA D110
Wire-Wound, Circular Prestressed Concrete Water Tanks

h. Fluid Controls Institute

FCI 70-2
Control Valve Seat Leakage

i. Instrument Society of America

ISA-S75.01
Flow Equations for Sizing Control Valves

j. Manufacturers Standardization Society of the Valve and Fittings Industry (MSS)

MSS SP-43
Wrought Stainless Steel Buttwelding Fittings

MSS SP-44
Steel Pipeline Flanges

MSS SP-51
Class 150LW Corrosion Resistant Cast Flanges and Flanged Fittings

MSS SP-58
Pipe Hangers and Supports - Materials, Design and Manufacturer

MSS SP-69
Pipe Hangers and Supports - Selection and Application

MSS SP-73
Brazing Joints for Wrought and Cast Copper Alloy Solder Joint Pressure Fittings

MSS SP-89
Pipe Hangers and Supports - Fabrication and Installation Practices

MSS SP-104
Wrought Copper Solder Joint Pressure Fittings

MSS SP-106
Cast Copper Alloy Flanges and Flanged Fittings

MSS SP-114
Corrosion Resistant Pipe Fittings Threaded and Socket Welding

MSS SP-119
Balled End Socket Welding Fittings, Stainless Steel and Copper-Nickel

k. National Association of Corrosion Engineers

NACE RP-0286
Electrical Isolation of Cathodically Protected Pipelines

l. National Fire Protection Association

NFPA 70
National Electric Code

A-3. Other Sources (Journals, Textbooks, Vendor Information, etc.)

ADSCO Manufacturing LLC, Expansion Joints Catalog 1196, Buffalo, New York, 1996.

American Institute of Steel Construction, Inc., Manual of Steel Construction, 8th Edition, Chicago, Illinois, 1980.

Asahi/America, Inc., Piping Systems Product Bulletin P-97/A, Malden, Massachusetts, 1997.

ASHRAE Handbook 2000, Heating, Ventilating and Air Conditioning, Atlanta, Georgia, 2000.

CMB Industries, FEBCO Backflow Prevention Service Information Model 765 Pressure Vacuum Breaker Assembly Catalog, Fresno, California, 1989.

Crane Company, Cast Steel Valves, Crane Valve Catalog, Joliet, Illinois, 1995.

Crane Company, Flow of Fluids, Technical Paper 410, Joliet, Illinois, 1995.

Crane/Resistoflex Corporation, "Plastic-Lined Piping Products Engineering Manual," Marion, North Carolina, 1998.

Dresser Industries, Inc., Style 38 Dresser Couplings for Steel Pipe Sizes, Sizes and Specifications, Form 877-0C, Bradford, Pennsylvania, 1995.

Fibercast Company, Piping Design Manual, FC-680, Sand Springs, Oklahoma, 1995.

Fisher Controls Company, Control Valve Handbook, 2nd Edition, Fisher Controls International, Inc., Marshalltown, Iowa, 1977.

Gardellin, David J., MOYNO® RKL Control Valve Sizing Handbook, Bulletin 250A, Robbins & Myers, Inc., Lumberton, New Jersey, 1982.

Harvel Plastics, Product Bulletin 112/401, Easton, Pennsylvania, 1995.

Hydraulic Institute Standards, 14th Edition, Hydraulic Institute, Cleveland, Ohio.

Hydraulic Institute Engineering Data Book, Hydraulic Institute, Cleveland, Ohio.

Rubber Manufacturers Association, The 1996 Hose Handbook, IP-2, Washington, D.C., 1996.

Schweitzer, Philip, A., P.E., Corrosion-Resistant Piping Systems, Marcel Dekker, Inc., New York, 1994.

Schweitzer, Phillip, A., P.E., Corrosion Resistance Tables, Metals, Nonmetals, Coatings, Mortars, Plastics, Elastomers and Linings, and Fabrics, 4th Edition, Marcel Dekker Inc., New York, 1995.

Spotts, M.F., Design of Machine Elements, 5th Edition, Prentice Hall, 1978.

Worcester Controls, A BTR Company, Series CPT Characterized Seat Control Valve Catalog, PB-V-3, Marlborough, Massachusetts, 1998.

A-4. Other Sources of Information (Not Referenced)

a. Metallic Piping Corrosion

Corrosion Data Survey, Metals Section, 6th Edition, National Association of Corrosion Engineers, Houston, Texas, 1985.

Phillip A. Schweitzer, Corrosion and Corrosion Protection Handbook, Marcel Dekker, Inc., New York, 1983.

b. Nonmetallic Piping Corrosion

Chemical Resistance Tables, Modern Plastics Encyclopedia, McGraw-Hill, New York, 1989.

Compass Corrosion Guide, La Mesa, California, 1983.

Corrosion Data Survey, Nonmetals Section, 5th Edition, National Association of Corrosion Engineers, Houston, Texas, 1985.

Handbook of PVC Pipe, 3rd Edition, Uni-Bell Plastic Pipe Association, Dallas, Texas, 1979.

c. Water Hammer

Ernest F. Braler and Horace W. King, Handbook of Hydraulics, 6th Ed.

Tyler & Hicks, Editor in Chief, Standard Handbook of Engineering Calculations, 3rd Ed.

d. Expansion Loops

Piping Design and Engineering, 5th Ed., ITT Grinnell Industrial Piping, Providence, Rhode Island, 1976.

Appendix B Fluid/Material Matrix

If a potentially corrosive fluid, or a piping material, is not found in the fluid/material matrix, then the reference materials listed in Appendix A should be directly reviewed. If the references cannot satisfactorily resolve the issue, then a special study may be required to determine material compatibility and acceptable use. If doubt of material suitability remains after the study due to exceptional conditions, a report should be submitted to HQUSACE (CEMP-EG).

B-1. Use of the Fluid/Material Matrix

The following matrix is arranged alphabetically according to the list of fluids typically found or used at hazardous and toxic waste remediation sites. Unless otherwise noted, the liquids are considered pure. All percentages shown are expressed in percent by weight.

a. Corrosion Resistivity

The matrix provides the temperature above ambient conditions of 15°C (60°F) at which corrosion or chemical resistivity of a material is acceptable for use with an identified fluid. For metals, an acceptable corrosion rate is less than 1.27 mm (50 mils) penetration per year. For non-metals and other materials, acceptability is considered based on the material's resistance to solvation or chemical reaction. Although materials may be corrosion resistant below the listed temperatures, other physical or mechanical properties of that material may preclude its acceptability for a specific use. A thorough evaluation considering all physical and mechanical properties of a material for its intended use is required.

b. Temperature Correlation

The matrix temperatures are provided in both the metric and IP units (degrees C and degrees F, respectively). Materials with unsatisfactory chemical resistance or corrosion rates at temperatures above ambient temperatures are indicated with a "U". Matrix entries for materials with insufficient information are left blank.

B-2. Material Abbreviations

ABS	- Acrylonitrile-butadiene-styrene
CPVC	- Chlorinated polyvinyl chloride
Resins	
Furan	- Furfural alcohol
Polyester	- Bisphenol A-fumarate
HDPE	- High density polyethylene
PP	- Polypropylene
PTFE	- Teflon ¹
PVC Type 2	- Polyvinyl chloride Type 2
PVDF	- Polyvinylidene fluoride
Butyl	- Butyl rubber GR-1 (IIR)
EPDM	- Ethylene-propylene-diene
EPT	- Ethylene-propylene terpolymer
FEP	- Perfluoroethylenepropylene
FKM	- Fluoroelastomer
Neoprene ²	- Polychloroprene
Nitrile	- Butadiene-acrylonitrile
N-Rubber	- Natural rubber
PFA	- Perfluoroalkoxyalkane copolymer
PVDC	- Polyvinylidene chloride
SBR Styrene	- Butadiene-styrene-elastomer

B-3. Matrix

Data contained within this matrix was obtained primarily from Schweitzer, Corrosion Resistance Tables, 4th Edition, see Appendix A for the complete reference information.

¹ Teflon is a registered trademark of E.I. DuPont.

² Neoprene is a registered trademark of E.I. DuPont.

Table B-1. Fluid/Material Matrix

FLUID/MATERIAL	Acetic Acid 10%	Acetic Acid 20%	Acetic Acid 50%	Acetic Acid 80%	Acetic Acid Glacial	Acetone	Aluminum Chloride, Aq.
METALS							
Aluminum	65 (150)	87 (190)	76 (170)	76 (170)	98 (210)	260 (500)	U
Bronze	93 (200)	U	U	U	U	204 (400)	U
Carbon Steel	U	U	U	U	U	149 (300)	U
Copper	38 (100)	U	U	U	U	60 (140)	26 (80)
Ductile Iron, Pearlitic							
Hastelloy C	149 (300)	149 (300)	149 (300)	149 (300)	293 (560)	93 (200)	98 (210)
Inconel	26 (80)	32 (90)	54 (130)	32 (90)	104 (220)	87 (180)	U
Monel	26 (80)	98 (210)	93 (200)	93 (200)	143 (290)	87 (180)	U
Nickel	32 (90)	32 (90)	60 (140)	49 (120)	U	87 (180)	149 (300)
304 SS	93 (200)	104 (220)	104 (220)	110 (230)	98 (210)	87 (180)	U
316 SS	216 (420)	204 (400)	204 (400)	110 (230)	204 (400)	204 (400)	U
NON-METALS							
ABS	38 (100)	54 (130)	53 (130)	U	U	U	60 (140)
CPVC	32 (90)	82 (180)	U	U	U	U	93 (200)
Resins - Epoxy	82 (190)	43 (110)	43 (110)	43 (110)		43 (110)	
- Furan	127 (260)	121 (230)	93 (200)	93 (200)	132 (270)	93 (200)	127 (260)
- Polyester	104 (220)	93 (200)	71 (160)	71 (160)	U	U	93 (200)
- Vinyl Ester	93 (200)	93 (200)	82 (180)	65 (150)	65 (150)	U	127 (260)
HDPE	60 (140)	60 (140)	60 (140)	26 (80)	38 (100)	49 (120)	60 (140)
PP	104 (220)	104 (220)	93 (200)	93 (200)	85 (190)	104 (220)	93 (200)
PTFE	243 (470)	243 (470)	243 (470)	243 (470)	243 (470)	243 (470)	243 (470)
PVC Type 2	38 (100)	60 (140)	32 (90)	U	U	U	60 (140)
PVDF	149 (300)	149 (300)	149 (300)	87 (190)	87 (190)	U	149 (300)
OTHER MATERIALS							
Butyl	65 (150)	65 (150)	43 (110)	43 (110)	32 (90)	71 (160)	65 (150)
EPDM	149 (300)	60 (140)	60 (140)	60 (140)	149 (300)	149 (300)	149 (300)
EPT	U	U	U	U	U	U	82 (180)
FEP	204 (400)	204 (400)	204 (400)	204 (400)	204 (400)	204 (400)	204 (400)
FKM	82 (180)	93 (200)	82 (180)	82 (180)	U	U	204 (400)
Borosilicate Glass	204 (400)	204 (400)	204 (400)	204 (400)	204 (400)	121 (250)	121 (250)
Neoprene	71 (160)	71 (160)	71 (160)	71 (160)	U	U	93 (200)
Nitrile	93 (200)	93 (200)	93 (160)	98 (210)	38 (100)	U	93 (200)
N-Rubber	65 (150)	26 (80)	U	U	U	U	60 (140)
PFA	93 (200)	93 (200)	93 (200)	93 (200)	121 (250)	93 (200)	93 (200)
PVDC	60 (140)	49 (120)	54 (130)	54 (130)	60 (140)	32 (90)	65 (150)
SBR Styrene	U	U	U	U	U	93 (200)	

Notes: U = unsatisfactory
 XX (XX) = degrees C (degrees F)

Table B-1. Fluid/Material Matrix

FLUID/MATERIAL	Aluminum Sulfate (Sat.)	Ammonia (Anhydrous)	Ammonia Hydroxide 10%	Ammonia Hydroxide 25%	Ammonia Hydroxide (Sat.)	Ammonium Nitrate	Benzene
METALS							
Aluminum	U	82 (180)	176 (350)	176 (350)	176 (350)	176 (350)	98 (210)
Bronze	98 (210)	26 (80)	U	U	U	U	204 (400)
Carbon Steel	U	204 (400)	98 (210)	98 (210)	98 (210)	U	60 (140)
Copper	26 (80)	26 (80)	U	U	U	U	38 (100)
Ductile Iron, Pearlitic	26 (80)				85 (185)		
Hastelloy C	98 (210)	298 (570)	98 (210)	398 (570)	398 (570)	32 (90)	98 (210)
Inconel	U	298 (570)	32 (90)	26 (80)	32 (90)	32 (90)	98 (210)
Monel	98 (210)	298 (570)	U	U	U	U	98 (210)
Nickel	98 (210)	32 (90)	U	U	149 (300)	32 (90)	98 (210)
304 SS	98 (210)	249 (480)	98 (210)	110 (230)	98 (210)	98 (210)	110 (230)
316 SS	98 (210)	298 (570)	98 (210)	110 (230)	98 (210)	149 (300)	204 (400)
NON-METALS							
ABS	60 (140)	U	26 (80)	32 (90)	26 (80)	60 (140)	U
CPVC	93 (200)	82 (180)	93 (200)	82 (180)	82 (180)	93 (200)	U
Resins - Epoxy	149 (300)	U	87 (190)	60 (140)	71 (160)	121 (250)	82 (180)
- Furan	127 (260)	127 (260)	82 (180)	127 (260)	93 (200)	127 (260)	127 (260)
- Polyester	93 (200)	104 (220)	60 (140)	38 (100)		104 (220)	U
- Vinyl Ester	121 (250)	104 (220)	66 (150)	66 (150)		121 (250)	U
HDPE	60 (140)	60 (140)	60 (140)	60 (140)	60 (10)	60 (140)	U
PP	104 (220)	104 (220)	104 (220)	93 (200)	93 (200)	93 (200)	60 (140)
PTFE	243 (470)	243 (470)	243 (470)	243 (470)	243 (470)	243 (470)	243 (470)
PVC Type 2	60 (140)	32 (90)	60 (140)	60 (140)	60 (140)	60 (140)	U
PVDF	149 (300)	138 (280)	138 (280)	138 (280)	138 (280)	138 (280)	65 (150)
OTHER MATERIALS							
Butyl	87 (190)	U	87 (190)	87 (190)	87 (190)	82 (180)	U
EPDM	149 (300)	149 (300)	98 (210)	38 (100)	149 (300)	149 (300)	U
EPT	60 (140)	60 (140)	60 (140)	60 (140)	60 (140)	82 (180)	U
FEP	204 (400)	204 (400)	204 (400)	204 (400)	204 (400)	204 (400)	204 (400)
FKM	198 (380)	U	87 (190)	87 (190)	87 (190)	U	204 (400)
Borosilicate Glass	121 (250)		122 (250)	122 (250)	122 (250)	93 (200)	121 (250)
Neoprene	93 (200)	93 (200)	90 (200)	93 (200)	98 (210)	93 (200)	U
Nitrile	93 (200)	87 (190)	93 (200)	93 (200)	98 (210)	82 (180)	U
N-Rubber	65 (150)	U	26 (80)	U	32 (90)	76 (170)	U
PFA	104 (220)	93 (200)	138 (280)	138 (280)	138 (280)	93 (200)	93 (200)
PVDC	82 (180)		U	U	U	49 (120)	26 (80)
SBR Styrene		93 (200)					U

Notes: U = unsatisfactory
XX (XX) = degrees C (degrees F)

Table B-1. Fluid/Material Matrix

FLUID/MATERIAL	Bleach 12.5% Active Cl	Calcium Chloride Dilute	Calcium Chloride (Sat.)	Calcium Hydroxide 10%	Calcium Hydroxide 20%	Calcium Hydroxide 30%	Calcium Hydroxide (Sat.)
METALS							
Aluminum	U	15 (60)	38 (100)	26 (80)	26 (80)	26 (80)	U
Bronze			98 (210)				
Carbon Steel	U	15 (60)	60 (140)	26 (80)	U	U	26 (80)
Copper		15 (60)	98 (210)	98 (210)	98 (210)	98 (210)	98 (210)
Ductile Iron, Pearlitic			98 (210)				
Hastelloy C		93 (200)	176 (350)	76 (170)	76 (170)	76 (170)	
Inconel		15 (60)	26 (80)	98 (210)	98 (210)	98 (210)	32 (90)
Monel		98 (210)	176 (350)	98 (210)	98 (210)	98 (210)	93 (200)
Nickel		15 (60)	26 (80)	98 (210)	98 (210)	98 (210)	93 (200)
304 SS		65 (150)	26 (80)	98 (210)	98 (210)	98 (210)	93 (200)
316 SS	U	60 (140)	98 (210)	98 (210)	98 (210)	98 (210)	
NON-METALS							
ABS	U	60 (140)	60 (140)			60 (140)	60 (140)
CPVC	93 (200)	82 (180)	82 (180)	76 (170)	76 (170)	76 (170)	98 (210)
Resins - Epoxy		93 (200)	87 (190)	98 (210)	93 (200)	93 (200)	82 (180)
- Furan		127 (260)	127 (260)	104 (220)	104 (220)	104 (220)	127 (260)
- Polyester		104 (220)	104 (220)	82 (180)	71 (160)	71 (160)	71 (160)
- Vinyl Ester		82 (180)	82 (180)	82 (180)	98 (210)	98 (210)	
HDPE	60 (140)	60 (140)	60 (140)	60 (140)	60 (140)	60 (140)	60 (140)
PP	60 (140)	104 (220)	104 (220)	93 (200)	93 (200)	93 (200)	104 (220)
PTFE	243 (470)	243 (470)	243 (470)	243 (470)	243 (470)	243 (470)	243 (470)
PVC Type 2	60 (140)	60 (140)	60 (140)				60 (140)
PVDF	138 (280)	138 (280)	138 (280)	132 (270)	132 (270)	149 (300)	138 (280)
OTHER MATERIALS							
Butyl	65 (150)	87 (190)	87 (190)	87 (190)	87 (190)	87 (190)	87 (190)
EPDM	149 (300)	98 (210)	98 (210)	98 (210)	98 (210)	98 (210)	149 (300)
EPT	U	82 (180)	82 (180)	82 (180)	82 (180)	82 (180)	98 (210)
FEP	204 (400)	204 (400)	204 (400)	204 (400)	204 (400)	204 (400)	204 (400)
FKM	204 (400)	143 (290)	149 (300)	149 (300)	149 (300)	149 (300)	204 (400)
Borosilicate Glass		122 (250)	121 (250)	U	U	U	U
Neoprene	32 (90)	93 (200)	93 (200)	104 (220)	104 (220)	104 (220)	104 (220)
Nitrile	U	93 (200)	82 (180)	82 (180)	76 (170)	82 (180)	82 (180)
N-Rubber	32 (90)	65 (150)	65 (150)	93 (200)	93 (200)	93 (200)	93 (200)
PFA		93 (200)	93 (200)	93 (200)	93 (200)	93 (200)	93 (200)
PVDC		82 (180)	138 (280)	71 (160)	71 (160)	71 (160)	71 (160)
SBR Styrene	93 (200)		93 (200)	93 (200)	93 (200)	93 (200)	93 (200)

Notes: U = unsatisfactory
XX (XX) = degrees C (degrees F)

Table B-1. Fluid/Material Matrix

FLUID/MATERIAL	Calcium Hypochlorite 30%	Calcium Hypochlorite (Sat.)	Chlorine Water (Sat.)	Chlorobenzene	Chloroform	Chlorophenol, 5% Aq.	Copper Sulfate
METALS							
Aluminum	U	U	26 (80)	65 (150)	76 (170)		U
Bronze	U	U	U	204 (400)	204 (400)		U
Carbon Steel	U	U	U	98 (210)	U	15 (60)	U
Copper	U	U	U	32 (90)	26 (80)		U
Ductile Iron, Pearlitic							
Hastelloy C			98 (210)	176 (350)	98 (210)		98 (210)
Inconel		U	32 (90)	98 (210)	98 (210)		32 (90)
Monel	U	U	U	204 (400)	98 (210)		32 (90)
Nickel		U	U	49 (120)	98 (210)		32 (90)
304 SS	U	U	U	98 (210)	98 (210)	176 (350)	98 (210)
316 SS		26 (80)	U	138 (280)	98 (210)	176 (350)	204 (400)
NON-METALS							
ABS		60 (140)	60 (140)	U	U		60 (140)
CPVC	82 (180)	93 (204)	98 (210)	U	U	U	98 (210)
Resins - Epoxy			U	87 (190)	43 (110)		98 (210)
- Furan	U		127 (260)	127 (260)	116 (240)	104 (220)	127 (260)
- Polyester	98 (210)		104 (220)	U	U		104 (220)
- Vinyl Ester		82 (180)	82 (180)	43 (110)	U		116 (240)
HDPE		60 (140)	60 (140)	U	26 (80)		60 (140)
PP	65 (170)	98 (210)	60 (140)	U	U		93 (200)
PTFE	93 (200)	243 (470)	243 (470)	243 (470)	243 (470)	243 (470)	243 (470)
PVC Type 2	60 (140)	60 (140)	60 (140)	U	U	U	60 (140)
PVDF	93 (200)	138 (280)	104 (220)	104 (220)	121 (250)	65 (150)	138 (280)
OTHER MATERIALS							
Butyl	U	65 (150)	U	U	U		87 (190)
EPDM	154 (310)	149 (300)	15 (60)	U	U		149 (300)
EPT		U	26 (80)	U	U		82 (180)
FEP		204 (400)	204 (400)	204 (400)	204 (400)	204 (400)	204 (400)
FKM	204 (400)	204 (400)	87 (190)	204 (400)	204 (400)		204 (400)
Borosilicate Glass		121 (250)	93 (200)	121 (250)	121 (250)		121 (200)
Neoprene	26 (80)	15 (60)	U	U	U		93 (200)
Nitrile	U	U	U	U	U		93 (200)
N-Rubber	U	32 (90)	65 (150)	U	U		65 (150)
PFA		93 (200)		93 (200)	93 (200)		93 (200)
PVDC		49 (120)	82 (180)	26 (80)	U		82 (180)
SBR Styrene		U			U		93 (200)

Notes: U = unsatisfactory
 XX (XX) = degrees C (degrees F)

Table B-1. Fluid/Material Matrix

FLUID/MATERIAL	Crude Oil	Cumene	Detergent Solution	Dichlorobenzene	Diesel Fuels	Ethyl Alcohol	Esters, General
METALS							
Aluminum	38 (100)			15 (60)	32 (90)	98 (210)	
Bronze	38 (100)				32 (90)	204 (400)	204 (400)
Carbon Steel	38 (100)			15 (60)	87 (190)	116 (240)	
Copper	26 (80)		15 (60)			38 (100)	
Ductile Iron, Pearlitic							
Hastelloy C	32 (90)	71 (160)		176 (350)	93 (200)	98 (210)	
Inconel						26 (80)	
Monel	149 (300)					98 (210)	
Nickel						93 (200)	
304 SS	98 (210)		82 (180)	26 (80)	32 (90)	93 (200)	
316 SS	98 (210)		82 (180)	43 (110)	32 (90)	93 (200)	204 (400)
NON-METALS							
ABS	32 (90)			U		49 (120)	
CPVC	98 (210)		71 (160)	U	38 (100)	82 (180)	U
Resins - Epoxy	149 (300)	60 (140)	121 (250)	87 (190)	122 (250)	66 (150)	71 (160)
- Furan		121 (250)		127 (260)	122 (250)	127 (260)	122 (250)
- Polyester	104 (220)	60 (140)		32 (90)	93 (200)	32 (90)	
- Vinyl Ester	121 (250)	60 (140)	49 (120)	43 (110)	104 (220)	38 (100)	66 (150)
HDPE	49 (120)		60 (140)	U	49 (120)	60 (140)	26 (80)
PP	65 (150)		65 (150)	65 (150)	38 (100)	82 (180)	
PTFE	243 (470)	149 (300)	243 (470)	243 (470)	243 (470)	243 (470)	244 (470)
PVC Type 2	60 (140)		60 (140)	U		60 (140)	U
PVDF	138 (280)			49 (120)	138 (280)	138 (280)	76 (170)
OTHER MATERIALS							
Butyl	U					88 (190)	
EPDM	U	U	143 (290)	U	U	144 (290)	
EPT	U		98 (210)	U	U	82 (180)	
FEP	204 (400)		204 (400)	204 (400)	204 (400)	204 (400)	204 (400)
FKM	149 (300)	209 (140)	204 (400)	82 (180)	204 (400)	176 (350)	
Borosilicate Glass			93 (200)	93 (200)		93 (200)	
Neoprene	U	U	71 (160)	U	26 (80)	93 (200)	
Nitrile	82 (180)	U	87 (190)	U	93 (200)	82 (180)	
N-Rubber	U			U	U	66 (150)	
PFA	93 (200)		93 (200)		93 (200)	93 (200)	
PVDC	65 (150)			U	49 (120)	66 (150)	26 (80)
SBR Styrene	U		93 (200)		93 (200)	93 (200)	

Notes: U = unsatisfactory
 XX (XX) = degrees C (degrees F)

Table B-1. Fluid/Material Matrix

FLUID/MATERIAL	Ethers, General	Ethyl Benzene	Ethylene Glycol	Ferric Chloride, 50% Aq.	Ferric Nitrate (Sat.)	Ferric Sulfate	Formaldehyde Dilute
METALS							
Aluminum	32 (90)	66 (150)	38 (100)	U		U	
Bronze	93 (200)	U	171 (340)	U	U	U	66 (150)
Carbon Steel	93 (200)	U	38 (100)	U	U	U	
Copper	26 (80)		38 (100)	U	U	26 (80)	
Ductile Iron, Pearlitic			149 (300)				
Hastelloy C	93 (200)	116 (240)	299 (570)	98 (210)	66 (150)	66 (150)	98 (210)
Inconel	32 (90)		98 (210)	26 (80)	U	U	98 (210)
Monel	32 (90)	82 (180)	98 (210)	U	U	26 (80)	98 (210)
Nickel	26 (80)		98 (210)	U	U	U	98 (210)
304 SS	93 (200)	20 (70)	98 (210)	U		26 (80)	298 (570)
316 SS	92 (200)	66 (150)	171 (340)	U	60 (140)	93 (200)	110 (230)
NON-METALS							
ABS	U		60 (140)			60 (140)	38 (100)
CPVC	U		98 (210)	82 (180)	82 (180)	82 (180)	60 (140)
Resins - Epoxy	32 (90)	U	149 (300)	122 (250)	93 (200)	93 (200)	44 (110)
- Furan	32 (90)	98 (210)	127 (260)	116 (240)	122 (250)	127 (260)	71 (160)
- Polyester		U	104 (220)	104 (220)	93 (200)	104 (220)	26 (80)
- Vinyl Ester	82 (180)	U	98 (210)	98 (210)	93 (200)	93 (200)	66 (150)
HDPE	U	20 (70)	60 (140)	60 (140)			60 (140)
PP	U	U	110 (230)	98 (210)	93 (200)	93 (200)	93 (200)
PTFE	244 (470)	243 (470)	243 (470)	243 (470)	243 (470)	243 (470)	149 (300)
PVC Type 2	U	U	60 (140)		60 (140)	60 (140)	60 (140)
PVDF	49 (120)	60 (140)	138 (280)	138 (280)	138 (280)	138 (280)	49 (120)
OTHER MATERIALS							
Butyl	U		88 (190)	71 (160)		88 (190)	
EPDM		U	149 (300)	149 (300)	144 (290)	138 (280)	60 (140)
EPT	U	U	82 (180)	82 (180)	82 (180)	82 (180)	82 (180)
FEP	204 (400)	49 (120)	204 (400)	204 (400)		204 (400)	204 (400)
FKM	U	204 (400)	204 (400)	204 (400)	204 (400)	204 (400)	110 (230)
Borosilicate Glass	66 (170)		122 (250)	138 (280)		93 (200)	
Neoprene	U	U	71 (160)	71 (160)		93 (200)	60 (140)
Nitrile	49 (120)	U	93 (200)	82 (180)	82 (180)	93 (200)	U
N-Rubber	U	U	66 (150)	66 (150)		66 (150)	
PFA	93 (200)		93 (200)	93 (200)		93 (200)	93 (200)
PVDC			82 (180)	60 (140)	49 (120)	66 (150)	60 (140)
SBR Styrene			93 (200)	93 (200)			93 (200)

Notes: U = unsatisfactory
 XX (XX) = degrees C (degrees F)

Table B-1. Fluid/Material Matrix

FLUID/MATERIAL	Formic Acid 5%	Formic Acid 10-85%	Formic Acid Anhydrous	Fuel Oil	Gasohol	Gasoline, Leaded	Gasoline, Refined
METALS							
Aluminum	U	98 (210)	98 (210)	60 (140)	66 (150)	38 (100)	98 (210)
Bronze		98 (210)	98 (210)	176 (350)	66 (150)	38 (100)	93 (200)
Carbon Steel		U	U	93 (200)	66 (150)	38 (100)	93 (200)
Copper	66 (150)	98 (210)	98 (210)	26 (80)	66 (150)	38 (100)	32 (90)
Ductile Iron, Pearlitic							
Hastelloy C	98(210)	98 (210)	98 (210)	93 (200)	66 (150)	38 (100)	93 (200)
Inconel	66 (150)	98 (210)	98 (210)	60 (140)		26 (80)	
Monel	66 (150)	98 (210)	98 (210)	82 (180)	66 (150)	38 (100)	38 (100)
Nickel	66 (150)	98 (210)	98 (210)	82 (180)		38 (100)	38 (100)
304 SS	66 (150)	104 (220)	54 (130)	122 (250)		32 (90)	132 (270)
316 SS	66 (150)	204 (400)	98 (210)	71 (160)	66 (150)	32 (90)	98 (210)
NON-METALS							
ABS		U	U		U	U	U
CPVC	26 (80)	60 (140)	76 (170)			U	66 (150)
Resins - Epoxy	38 (100)	20 (70)	32 (90)	122 (250)		122 (250)	66 (150)
- Furan	104 (220)	127 (260)	U	122 (250)		122 (250)	127 (260)
- Polyester	66 (150)	66 (150)	38 (100)	26 (80)		32 (90)	26 (80)
- Vinyl Ester	82 (180)	38 (100)	U	93 (200)		44 (110)	82 (180)
HDPE	60 (140)	60 (140)	71 (160)	93 (200)		U	U
PP	66 (150)	98 (210)	82 (180)	76 (170)	U	U	U
PTFE	243 (470)	243 (470)	243 (470)	243 (470)	93 (200)	243 (470)	243 (470)
PVC Type 2		32 (90)		60 (140)	60 (140)		U
PVDF	122 (250)	122 (250)	60 (140)	138 (280)	138 (280)	138 (280)	
OTHER MATERIALS							
Butyl	66 (150)	66 (150)	66 (150)	U			
EPDM	98 (210)	149 (300)	32 (90)	U	U	U	
EPT	93 (200)	82 (180)	98 (210)			U	U
FEP	204 (400)	204 (400)	204 (400)	204 (400)		204 (400)	204 (400)
FKM	82 (180)	88 (190)	66 (150)	199 (390)	32 (100)	88 (190)	82 (180)
Borosilicate Glass	122 (250)	122 (250)	122 (250)	122 (250)		71 (160)	122 (250)
Neoprene	93 (200)	71 (160)	38 (100)	93 (200)		32 (90)	32 (90)
Nitrile	U	U	U	104 (220)	26 (80)	88 (190)	93 (200)
N-Rubber		U	U	U		U	U
PFA	93 (200)	93 (200)	93 (200)	93 (200)		93 (200)	93 (200)
PVDC	66 (150)	66 (150)	66 (150)	49 (120)		71 (160)	32 (90)
SBR Styrene						U	U

Notes: U = unsatisfactory
 XX (XX) = degrees C (degrees F)

Table B-1. Fluid/Material Matrix

FLUID/MATERIAL	Gasoline, Unleaded	Glycols	Heptane	Hexane	Hydrochloric Acid, Dilute	Hydrochloric Acid 20%	Hydrochloric Acid 35%
METALS							
Aluminum	98 (210)	26 (80)	38 (100)	26 (80)	U	U	U
Bronze	176 (350)	38 (100)	176 (350)	176 (350)	U	U	U
Carbon Steel	176 (350)	26 (80)	176 (350)	176 (350)	U	U	U
Copper	32 (90)		26 (80)		U	U	U
Ductile Iron, Pearlitic							
Hastelloy C	160 (320)		93 (200)	122 (250)	82 (180)	66 (150)	66 (150)
Inconel	26 (80)	38 (100)	93 (200)		32 (90)	26 (80)	U
Monel	38 (100)	38 (100)	93 (200)	38 (100)	32 (90)	26 (80)	U
Nickel	38 (100)		98 (210)	26 (80)	32 (90)	26 (80)	U
304 SS	26 (80)	38 (100)	122 (250)	122 (250)	U	U	U
316 SS	26 (80)	26 (80)	176 (350)	122 (250)	U	U	U
NON-METALS							
ABS	U	60 (140)	54 (130)	U	32 (90)	32 (90)	60 (140)
CPVC	U	82 (180)	82 (180)	66 (150)	82 (180)	82 (180)	66 (150)
Resins - Epoxy	122 (250)	149 (300)	66 (150)	82 (180)	88 (190)	93 (200)	32 (90)
- Furan	138 (280)		98 (210)	66 (150)	127 (260)	127 (260)	122 (250)
- Polyester	32 (90)	104 (220)	93 (200)	32 (90)	88 (190)	88 (190)	54 (130)
- Vinyl Ester	38 (100)	98 (210)	98 (210)	71 (160)	110 (230)	104 (220)	82 (180)
HDPE	60 (140)	60 (140)	44 (110)	26 (80)	71 (160)	60 (140)	60 (140)
PP	U	66 (150)	26 (80)	44 (110)	104 (220)	104 (220)	104 (220)
PTFE	243 (470)	243 (470)	243 (470)	243 (470)	243 (470)	243 (470)	243 (470)
PVC Type 2		60 (140)	60 (140)	20 (70)	60 (140)	60 (140)	60 (140)
PVDF	138 (280)	138 (280)	138 (280)	138 (280)	138 (280)	138 (280)	138 (280)
OTHER MATERIALS							
Butyl		66 (150)		U	49 (120)	U	U
EPDM	U	149 (300)	U	U	149 (300)	38 (100)	32 (90)
EPT	U	98 (210)	U	U	98 (210)	U	U
FEP	204 (400)	204 (400)	204 (400)	204 (400)	204 (400)	204 (400)	204 (400)
FKM	82 (180)	204 (400)	176 (350)	210 (410)	176 (350)	176 (350)	176 (350)
Borosilicate Glass	76 (170)		122 (250)	122 (250)	122 (250)	122 (250)	122 (250)
Neoprene	93 (200)	71 (160)	93 (200)	93 (200)	66 (150)	82 (180)	82 (180)
Nitrile	93 (200)	104 (220)	82 (180)	104 (220)	66 (150)	54 (130)	U
N-Rubber	U	49 (120)	U	U	60 (140)	66 (150)	82 (180)
PFA	93 (200)	93 (200)	93 (200)	93 (200)	122 (250)	122 (250)	122 (250)
PVDC	66 (150)		66 (150)	66 (150)	82 (180)	82 (180)	82 (180)
SBR Styrene	U		U	U			U

Notes: U = unsatisfactory
 XX (XX) = degrees C (degrees F)

Table B-1. Fluid/Material Matrix

FLUID/MATERIAL	Hydrochloric Acid 38%	Hydrochloric Acid 50%	Hydrofluoric Acid, Dilute	Hydrofluoric Acid 30%	Hydrofluoric Acid 40%	Hydrofluoric Acid 50%	Hydrofluoric Acid 70%
METALS							
Aluminum	U	U	U	U	U	U	U
Bronze	U	U	66 (150)	60 (140)	26 (80)	U	U
Carbon Steel	U	U	U	U	U	U	U
Copper	U	U	66 (150)	60 (140)	26 (80)	U	U
Ductile Iron, Pearlitic							
Hastelloy C	60 (150)	26 (80)	98 (210)	98 (210)	93 (200)	110 (230)	93 (200)
Inconel	U	U	26 (80)	U	U	U	U
Monel	U	U	204 (400)	204 (400)	204 (400)	204 (400)	204 (400)
Nickel	U	U	44 (110)	76 (170)	60 (140)	71 (160)	38 (100)
304 SS	U	U	U	U	U	U	U
316 SS	U	U	U	U	U	U	U
NON-METALS							
ABS	60 (140)	54 (130)	U	U	U	U	U
CPVC	76 (170)	82 (180)	26 (80)	U	76 (170)	U	32 (90)
Resins - Epoxy	60 (140)	104 (220)	U	U	U	U	U
- Furan	122 (250)	32 (90)	127 (260)	U	U	U	
- Polyester	U	32 (90)	38 (100)	32 (90)	U		
- Vinyl Ester	82 (180)	60 (140)	71 (160)	U	U	U	U
HDPE	60 (140)	60 (140)	60 (140)	60 (140)	60 (140)	60 (140)	U
PP	93 (200)	44 (110)	93 (200)	82 (180)	93 (200)	93 (200)	93 (200)
PTFE	243 (470)	243 (470)	243 (470)	243 (470)	243 (470)	243 (470)	243 (470)
PVC Type 2	60 (140)	60 (140)	32 (90)	54 (130)	66 (150)	20 (70)	
PVDF	138 (280)	138 (280)	138 (280)	127 (260)	116 (240)	104 (220)	98 (210)
OTHER MATERIALS							
Butyl	U	54 (130)	176 (350)	176 (350)	66 (150)	66 (150)	66 (150)
EPDM	60 (140)		15 (60)	15 (60)	15 (60)	U	U
EPT	32 (90)	U	98 (210)	60 (140)	U	U	U
FEP	204 (400)	204 (400)	204 (400)	204 (400)	204 (400)	204 (400)	204 (400)
FKM	176 (350)	138 (280)	98 (210)	98 (210)	176 (350)	176 (350)	176 (350)
Borosilicate Glass	122 (250)	122 (250)	U	U	U	U	U
Neoprene	32 (90)	U	93 (200)	93 (200)	93 (200)	93 (200)	93 (200)
Nitrile	U	93 (200)	U	U	U	U	U
N-Rubber	82 (180)	82 (90)	38 (100)	38 (100)	32 (90)	38 (100)	U
PFA	93 (200)	93 (200)	93 (200)	93 (200)	93 (200)	93 (200)	93 (200)
PVDC	82 (180)	82 (180)	82 (180)	71 (160)	76 (170)	66 (150)	
SBR Styrene	U	U	U	U	U	U	U

Notes: U = unsatisfactory
XX (XX) = degrees C (degrees F)

Table B-1. Fluid/Material Matrix

FLUID/MATERIAL	Hydrofluoric Acid 100%	Hydrogen Peroxide, Dilute	Hydrogen Peroxide 30%	Hydrogen Peroxide 50%	Hydrogen Peroxide 90%	Hydrogen Sulfide, Aq. Soln.	Jet Fuel JP-4
METALS							
Aluminum	U	176 (350)	176 (350)	15 (60)	176 (350)		76 (170)
Bronze	72 (160)	U	U	U	32 (90)		204 (400)
Carbon Steel	66 (150)	U	U	U	U		76 (170)
Copper	U	U	U	U	U		
Ductile Iron, Pearlitic							
Hastelloy C	98 (210)	93 (200)	38 (100)	38 (100)	93 (200)	149 (300)	38 (100)
Inconel	49 (120)	66 (150)	60 (140)	26 (80)	32 (90)	93 (200)	32 (90)
Monel	98 (210)	49 (120)	15 (60)	32 (90)	32 (90)	98 (210)	32 (90)
Nickel	49 (120)	76 (170)			32 (90)	93 (200)	26 (80)
304 SS	U	98 (210)	98 (210)	93 (200)	93 (200)	U	38 (100)
316 SS	26 (80)	216 (420)	204 (400)	204 (400)	204 (400)	93 (200)	204 (400)
NON-METALS							
ABS	U	26 (80)	U	U	U	60 (140)	
CPVC	U	U	82 (180)	82 (180)	82 (180)	82 (180)	93 (200)
Resins - Epoxy	U	66 (150)	60 (140)	U	U	149 (300)	66 (150)
- Furan	138 (280)	U	U		26 (80)	127 (260)	60 (140)
- Polyester		66 (150)	32 (90)	U	U		26 (80)
- Vinyl Ester	U	60 (140)	76 (170)	44 (110)	66 (150)	71 (160)	82 (180)
HDPE		49 (120)	60 (140)	60 (140)	26 (80)	60 (140)	
PP	93 (200)	38 (100)	38 (100)	66 (150)	44 (110)	82 (180)	20 (70)
PTFE	243 (470)	243 (470)	243 (470)	243 (470)	244 (470)	243 (470)	243 (470)
PVC Type 2			U	38 (100)	U	60 (140)	60 (140)
PVDF	93 (200)	122 (250)	122 (250)	122 (250)	49 (120)	104 (220)	122 (250)
OTHER MATERIALS							
Butyl	U	U	U	U	U		U
EPDM	U	38 (100)	38 (100)	38 (100)	38 (100)	60 (140)	U
EPT	U	26 (80)	U	U	U	82 (180)	U
FEP	204 (400)	204 (400)	204 (400)	204 (400)	204 (400)	204 (400)	204 (400)
FKM	20 (70)	176 (350)	176 (350)	176 (350)	122 (250)	U	204 (400)
Borosilicate Glass	U	122 (250)	122 (250)	122 (250)	122 (250)	44 (110)	82 (180)
Neoprene	U	U	U	U	U		U
Nitrile	U	32 (90)	32 (90)	U	U	U	93 (200)
N-Rubber	U	26 (80)	U	U	U		U
PFA	93 (200)	93 (200)	93 (200)	93 (200)	93 (200)		93 (200)
PVDC	U	49 (120)	49 (120)	54 (130)	49(120)	71 (160)	26 (80)
SBR Styrene	U	93 (200)					U

Notes: U = unsatisfactory
XX (XX) = degrees C (degrees F)

Table B-1. Fluid/Material Matrix

FLUID/MATERIAL	Jet Fuel JP-5	Kerosene	Ketones, General	Lime Slurry	Lubricating Oil	Machine Oil	Methyl Alcohol
METALS							
Aluminum	38 (100)	76 (170)	38 (100)		66 (150)		66 (150)
Bronze	204 (400)	176 (350)	38 (100)	66 (150)			188 (370)
Carbon Steel	38 (100)	176 (350)	93 (200)	66 (150)	66 (150)	98 (210)	98 (210)
Copper		32 (90)			32 (90)		98 (210)
Ductile Iron, Pearlitic							
Hastelloy C	38 (100)	98 (210)	38 (100)	49 (120)		98 (210)	122 (250)
Inconel	26 (80)	32 (90)					98 (210)
Monel	38 (100)	76 (170)	38 (100)	66 (150)	38 (100)		98 (210)
Nickel	26 (80)	98 (210)	38 (100)				98 (210)
304 SS	38 (100)	204 (400)	122 (250)		66 (150)	98 (210)	122 (250)
316 SS	204 (400)	204 (400)	132 (270)	66 (150)	66 (150)	98 (210)	176 (350)
NON-METALS							
ABS		32 (90)	U		38 (100)		U
CPVC	60 (140)	82 (180)	U		82 (180)	82 (180)	66 (150)
Resins - Epoxy	66 (150)	122 (250)	U	93 (200)	110 (230)		32 (90)
- Furan	66 (150)	122 (250)	38 (100)				122 (250)
- Polyester	32 (90)	66 (150)		98 (210)			66 (150)
- Vinyl Ester	49 (120)	132 (270)	U	82 (180)	93 (200)		38 (100)
HDPE		26 (80)	26 (80)		U		60 (140)
PP	20 (70)	32 (90)	44 (110)		20 (70)	44 (110)	88 (190)
PTFE	243 (470)	243 (470)	243 (470)	82 (180)	243 (470)	243 (470)	243 (470)
PVC Type 2	60 (140)	60 (140)	U		60 (140)	60 (140)	60 (140)
PVDF	122 (250)	127 (260)	44 (110)		138 (280)	93 (200)	138 (280)
OTHER MATERIALS							
Butyl	U	U			U	U	88 (190)
EPDM	U	U	U	38 (100)	U	U	149 (300)
EPT	U	U			U	204 (400)	60 (140)
FEP	204 (400)	204 (400)	204 (400)		204 (400)	60 (140)	204 (400)
FKM	204 (400)	204 (400)	U		204 (400)	93 (200)	U
Borosilicate Glass	82 (180)	122 (250)	122 (250)		70 (160)		122 (250)
Neoprene	U	93 (200)	U	82 (180)	93 (200)	93 (200)	104 (220)
Nitrile	93 (200)	110 (230)	U		104 (220)		104 (220)
N-Rubber	U	U			U		71 (160)
PFA	93 (200)	93 (200)	93 (200)		93 (200)		93 (200)
PVDC	32 (90)	49 (120)	32 (90)		49 (120)		71 (160)
SBR Styrene	U	U			U		93 (200)

Notes: U = unsatisfactory
XX (XX) = degrees C (degrees F)

Table B-1. Fluid/Material Matrix

FLUID/MATERIAL	Methyl Ethyl Ketone (MEK)	Methyl Isobutyl Ketone	Methylene Chloride	Mineral Oil	Mixed Acids	Motor Oil	Naphtha
METALS							
Aluminum	60 (140)	66 (150)	98 (210)	76 (170)	U		82 (180)
Bronze	176 (350)	176 (350)	204 (400)		U	38 (100)	204 (400)
Carbon Steel	93 (200)	66 (150)	38 (100)	38 (100)	U	122 (250)	32 (90)
Copper	32 (90)	32 (90)	32 (90)	32 (90)		66 (150)	32 (90)
Ductile Iron, Pearlitic							
Hastelloy C	98 (210)	93 (200)	98 (210)				93 (200)
Inconel	98 (210)	93 (200)	98 (210)	38 (100)	32 (90)	32 (90)	66 (150)
Monel	93 (200)	93 (200)	98 (210)	38 (100)	U	32 (90)	49 (120)
Nickel		93 (200)	98 (210)	38 (100)	U		49 (120)
304 SS	66 (150)	93 (200)	98 (210)	32 (90)	66 (150)	122 (250)	122 (250)
316 SS	176 (350)	176 (350)	204 (400)	176 (350)	66 (150)	122 (250)	98 (210)
NON-METALS							
ABS	U	U	U	38 (100)		32 (90)	60 (140)
CPVC	U	U	U	82 (180)	93 (200)	82 (180)	60 (140)
Resins - Epoxy	32 (90)	60 (140)	20 (70)	110 (230)		26 (80)	104 (220)
- Furan	76 (170)	122 (250)	138 (280)		U		127 (260)
- Polyester	U	U	U	98 (210)			66 (150)
- Vinyl Ester	U	U	U	122 (250)		122 (250)	98 (210)
HDPE	U		U	26 (80)			26 (80)
PP	66 (150)	26 (60)	20 (70)	44 (110)	U	U	44 (110)
PTFE	243 (470)	243 (470)	243 (470)	243 (470)	243 (470)	243 (470)	243 (470)
PVC Type 2	U	U	U	60 (140)	20 (70)	60 (140)	60 (140)
PVDF	U	44 (110)	49 (120)	122 (250)		122 (250)	138 (280)
OTHER MATERIALS							
Butyl	38 (100)	26 (80)	U	U			U
EPDM	149 (300)	15 (60)	U	U		U	U
EPT	U	U	U	U		U	U
FEP	204 (400)	204 (400)	204 (400)	204 (400)	204 (400)	204 (400)	204 (400)
FKM	U	U	20 (70)	210(410)	38 (100)	88 (190)	204 (400)
Borosilicate Glass	122 (250)	122 (250)	122 (250)	76 (170)		160 (320)	93 (200)
Neoprene	U	U	U	93 (200)	U		U
Nitrile	U	U	U	82 (180)	U	88 (190)	60 (140)
N-Rubber	U	U	U	U			U
PFA	93 (200)	93 (200)	93 (200)	93 (200)	93 (200)	93 (200)	93 (200)
PVDC	U	26 (80)	U	49 (120)			66 (150)
SBR Styrene	U		U	U			U

Notes: U = unsatisfactory
 XX (XX) = degrees C (degrees F)

Table B-1. Fluid/Material Matrix

FLUID/MATERIAL	Naphthalene	Nitric Acid 5%	Nitric Acid 10%	Nitric Acid 20%	Nitric Acid 30%	Nitric Acid 40%	Nitric Acid 50%
METALS							
Aluminum	98 (210)	U	U	U	U	U	U
Bronze	38 (100)	U	U	U	U	U	U
Carbon Steel	82 (180)	U	U	U	U	U	U
Copper	38 (100)	U	U	U	U	U	U
Ductile Iron, Pearlitic							
Hastelloy C	93 (200)	98 (210)	98 (210)	88 (190)	88 (190)	82 (180)	110 (230)
Inconel	98 (210)	32 (90)	32 (90)	26 (80)	26 (80)	26 (80)	26 (80)
Monel	98 (210)	U	U	U	U	U	U
Nickel	98 (210)	U	U	U	U	U	U
304 SS	204 (400)	98 (210)	160 (320)	149 (300)	98 (210)	98 (210)	93 (200)
316 SS	204 (400)	98 (210)	98 (210)	144 (290)	149 (300)	104 (220)	93 (200)
NON-METALS							
ABS	U	60 (140)	60 (140)	54 (130)	U	U	U
CPVC	U	82 (180)	82 (180)	71 (160)	93 (200)	82 (180)	82 (180)
Resins - Epoxy	93 (200)	71 (160)	60 (140)	38 (100)	U	U	U
- Furan	127 (260)	93 (200)	26 (80)	U	U	U	U
- Polyester	82 (180)	71 (160)	66 (150)	38 (100)	26 (80)	98 (210)	26 (80)
- Vinyl Ester	98 (210)	82 (180)	66 (150)	66 (150)	38 (100)	98 (210)	U
HDPE	26 (80)	60 (140)	60 (140)	60 (140)	60 (140)	U	U
PP	98 (210)	60 (140)	93 (200)	60 (140)	66 (150)	66 (150)	66 (150)
PTFE	243 (470)	243 (470)	243 (470)	243 (470)	243 (470)	243 (470)	243 (470)
PVC Type 2	U	38 (100)	60 (140)	60 (140)	60 (140)	60 (140)	60 (140)
PVDF	138 (280)	93 (200)	93 (200)	82 (180)	82 (180)	82 (180)	82 (180)
OTHER MATERIALS							
Butyl		71 (160)	71 (160)	71 (160)	49 (120)	38 (100)	U
EPDM	U	15 (160)	15 (160)	15 (160)	15 (60)	U	U
EPT	U	U	U	U	U	U	U
FEP	204 (400)	204 (400)	204 (400)	204 (400)	204 (400)	204 (400)	204 (400)
FKM	204 (400)	204 (400)	204 (400)	204 (400)	204 (400)	204 (400)	204 (400)
Borosilicate Glass		204 (400)	204 (400)	204 (400)	15 (60)	204 (400)	15 (60)
Neoprene	U	U	U	U	U	U	U
Nitrile	U	U	U	U	U	U	U
N-Rubber	U	U	U	U	U	U	U
PFA	93 (200)	93 (200)	93 (200)	93 (200)	93 (200)	93 (200)	93 (200)
PVDC		32 (90)	54 (130)	66 (150)	66 (150)	49 (120)	49 (120)
SBR Styrene		U	U	U	U	U	U

Notes: U = unsatisfactory
 XX (XX) = degrees C (degrees F)

Table B-1. Fluid/Material Matrix

FLUID/MATERIAL	Nitric Acid 70%	Nitric Acid 100% (Anhydrous)	Oil and Fats	Oxalic Acid 5%	Oxalic Acid 10%	Oxalic Acid 50%	Oxalic Acid (Sat.)
METALS							
Aluminum	U	32 (90)	66 (150)	88 (190)	44 (110)	88 (190)	54 (130)
Bronze	U	U	66 (150)	98 (210)	98 (210)	98 (210)	98 (210)
Carbon Steel	U	U	66 (150)	U	U	U	U
Copper	U	U		98 (210)	98 (210)	98 (210)	98 (210)
Ductile Iron, Pearlitic							
Hastelloy C	93 (200)	26 (80)	122 (250)	98 (210)	98 (210)	98 (210)	98 (210)
Inconel	U	U		98 (210)	98 (210)	98 (210)	26 (80)
Monel	U	U		98 (210)	98 (210)	66 (150)	32 (90)
Nickel	U	U	15 (60)	32 (90)	38 (100)	49 (120)	98 (210)
304 SS	98 (210)	26 (80)	66 (150)	U	U	U	U
316 SS	204 (400)	44 (110)	122 (250)	176 (350)	176 (350)	176 (350)	U
NON-METALS							
ABS	U	U	60 (140)	60 (140)	38 (100)	38 (100)	38 (100)
CPVC	82 (180)	U	98 (210)	60 (140)	88 (190)	98 (210)	93 (200)
Resins - Epoxy	U	U		132 (270)	132 (270)	132 (270)	132 (270)
- Furan	U	U	122 (250)	88 (190)	93 (200)		
- Polyester			104 (220)	104 (220)	104 (220)	104 (220)	104 (220)
- Vinyl Ester	U	U	98 (210)	98 (210)	93 (200)	98 (210)	98 (210)
HDPE	U	U	U	60 (140)	60 (140)	60 (140)	60 (140)
PP	U	U	82 (180)	71 (160)	66 (150)	66 (150)	60 (140)
PTFE	243 (470)	243 (470)	243 (470)	243 (470)	243 (470)	243 (470)	243 (470)
PVC Type 2	60 (140)	U	60 (140)	60 (140)	60 (140)	60 (140)	60 (140)
PVDF	49 (120)	66 (150)	144 (290)	71 (160)	66 (150)	93 (200)	60 (140)
OTHER MATERIALS							
Butyl	32 (90)	U		76 (170)	88 (190)	66 (150)	66 (150)
EPDM	U	U		154 (310)	149 (300)	149 (300)	144 (290)
EPT	U	U	U	60 (140)	60 (140)	60 (140)	98 (210)
FEP	204 (400)	204 (400)	204 (400)	204 (400)	204 (400)	204 (400)	204 (400)
FKM	88 (190)	88 (190)	82 (180)	204 (400)	204 (400)	204 (400)	204 (400)
Borosilicate Glass	204 (400)	132 (270)	93 (200)	122 (250)	122 (250)	122 (250)	122 (250)
Neoprene	U	U	26 (80)	93 (200)	93 (200)	38 (100)	U
Nitrile	U	U	93 (200)	U	U	U	20 (70)
N-Rubber	U	U		66 (150)	66 (150)	66 (150)	66 (150)
PFA	122 (250)	26 (80)	93 (200)				
PVDC	U	U	66 (150)	82 (180)	76 (170)	76 (170)	49 (120)
SBR Styrene	U	U					

Notes: U = unsatisfactory
 XX (XX) = degrees C (degrees F)

Table B-1. Fluid/Material Matrix

FLUID/MATERIAL	Petroleum Oils, Refined	Petroleum Oils, Sour	Phenol	Phenol 10%	Phosphoric Acid 5%	Phosphoric Acid 10%	Phosphoric Acid 25-50%
METALS							
Aluminum	32 (90)	U	98 (210)	66 (150)	U	38 (100)	U
Bronze	26 (80)	U	U	38 (100)	U	U	65 (150)
Carbon Steel			98 (210)	93 (200)		U	U
Copper	32 (90)	U	U	49 (120)	32 (90)	U	U
Ductile Iron, Pearlitic							
Hastelloy C			299 (570)	176 (350)	32 (90)	98 (210)	98 (210)
Inconel			299 (570)	49 (120)	26 (80)	93 (200)	98 (210)
Monel	32 (90)	U	299 (570)	104 (220)	26 (80)	26 (80)	26 (80)
Nickel			299 (570)	93 (200)		26 (80)	26 (80)
304 SS	26 (80)	26 (80)	299 (570)	93 (200)	93 (200)	88 (190)	98 (210)
316 SS	26 (80)	26 (80)	299 (570)	93 (200)	98 (210)	144 (290)	93 (200)
NON-METALS							
ABS			U	U		60 (140)	38 (100)
CPVC	82 (180)	82 (180)	60 (140)	32 (90)	98 (210)	82 (180)	82 (180)
Resins - Epoxy			U	U	38 (100)	71 (160)	60 (140)
- Furan			98 (210)	U		122 (250)	121 (250)
- Polyester			U	U		104 (220)	104 (220)
- Vinyl Ester	93 (200)	93 (200)	U	38 (100)	98 (210)	93 (200)	93 (200)
HDPE	26 (80)	26 (80)	38 (100)	38 (100)	60 (140)	60 (140)	60 (140)
PP	66 (150)	32 (90)	82 (180)	93 (200)	82 (180)	122 (250)	98 (210)
PTFE	243 (470)	243 (470)	243 (470)	243 (470)	243 (470)	243 (470)	243 (470)
PVC Type 2			U	U		60 (140)	60 (140)
PVDF	127 (260)	122 (250)	93 (200)	98 (210)	132 (270)	138 (280)	121 (250)
OTHER MATERIALS							
Butyl			66 (150)	66 (150)	66 (150)	66 (150)	87 (190)
EPDM	U		15 (60)	26 (80)	149 (300)	149 (300)	60 (140)
EPT	U	U	26 (80)	26 (80)	82 (180)	82 (180)	82 (180)
FEP	204 (400)	204 (400)	204 (400)	204 (400)	204 (400)	204 (400)	204 (400)
FKM	88 (190)	88 (190)	98 (210)	216 (420)	204 (400)	204 (400)	87 (190)
Borosilicate Glass			93 (200)	93 (200)	149 (300)	149 (300)	149 (300)
Neoprene	38 (100)		U	U	93 (200)	93 (200)	82 (180)
Nitrile	82 (180)	82 (180)	U	U	U	U	U
N-Rubber	U		U	26 (80)	66 (150)	66 (150)	65 (150)
PFA					93 (200)	93 (200)	93 (200)
PVDC			U	26 (80)	76 (170)	82 (180)	49 (120)
SBR Styrene	U	U	U	U	93 (200)	93 (200)	

Notes: U = unsatisfactory
 XX (XX) = degrees C (degrees F)

Table B-1. Fluid/Material Matrix

FLUID/MATERIAL	Phosphoric Acid 50-85%	Potassium Hydroxide 5%	Potassium Hydroxide 27%	Potassium Hydroxide 50%	Potassium Hydroxide 90%	Potassium Nitrate 1-5%	Potassium Nitrate 80%
METALS							
Aluminum	U	U	U	U	U	176 (350)	176 (350)
Bronze	U	32 (90)	15 (60)	32 (90)	26 (80)		98 (210)
Carbon Steel	U	98 (210)	93 (200)	32 (90)	26 (80)		54 (130)
Copper	U	38 (100)	32 (90)	98 (210)	26 (80)		32 (93)
Ductile Iron, Pearlitic							
Hastelloy C	98 (210)	98 (210)	127 (260)	127 (260)	65 (150)	98 (210)	98 (210)
Inconel	87 (190)	98 (210)	98 (210)	98 (210)	26 (80)	98 (210)	98 (210)
Monel	204 (400)	98 (210)	98 (210)	98 (210)	98 (210)	98 (210)	98 (210)
Nickel	U	98 (210)	98 (210)	98 (210)	98 (210)	98 (210)	98 (210)
304 SS	49 (120)	149 (300)	98 (210)	98 (210)	U	121 (250)	121 (250)
316 SS	204 (400)	176 (330)	176 (350)	171 (340)	176 (350)	176 (350)	176 (350)
NON-METALS							
ABS	54 (130)	60 (140)	60 (140)	60 (140)	60 (140)	60 (140)	60 (140)
CPVC	82 (180)	82 (180)	82 (180)	82 (180)	127 (260)	82 (180)	82 (180)
Resins - Epoxy	43 (110)	93 (200)	82 (180)	98 (210)	65 (150)	127 (260)	149 (300)
- Furan	127 (260)	121 (250)	121 (250)	121 (250)	132 (270)		132 (270)
- Polyester	104 (220)	65 (150)	32 (90)	76 (170)		104 (220)	104 (220)
- Vinyl Ester	98 (210)	65 (150)	65 (150)	U	U	104 (220)	98 (210)
HDPE	38 (100)	60 (140)	60 (140)	60 (140)	60 (140)	60 (140)	60 (140)
PP	98 (210)	98 (210)	65 (150)	82 (180)	65 (150)	56 (150)	56 (150)
PTFE	243 (470)	243 (470)	243 (470)	243 (470)	243 (470)	243 (470)	243 (470)
PVC Type 2	60 (140)	60 (140)	60 (140)	60 (140)	60 (140)	60 (140)	60 (140)
PVDF	121 (250)	98 (210)	104 (220)	98 (210)	98 (210)	138 (280)	138 (280)
OTHER MATERIALS							
Butyl	65 (150)	82 (180)	82 (108)	82 (180)	82 (180)		82 (180)
EPDM	60 (140)	149 (300)	149 (300)	149 (300)	149 (300)	149 (300)	149 (300)
EPT	82 (180)	98 (210)	98 (210)	98 (210)	98 (210)	82 (180)	82 (180)
FEP	204 (400)	204 (400)	204 (400)	204 (400)	204 (400)	204 (400)	204 (400)
FKM	149 (300)	160 (320)	26 (80)	U	U	204 (400)	204 (400)
Borosilicate Glass	149 (300)	U	U	U	U	121 (250)	121 (250)
Neoprene	60 (140)	93 (200)	93 (200)	93 (200)	93 (200)	93 (200)	93 (200)
Nitrile	U	26 (80)	15 (60)	65 (150)	65 (150)	104 (220)	104 (220)
N-Rubber	43 (110)	38 (100)	38 (100)	38 (100)	38 (100)		65 (150)
PFA	93 (200)	93 (200)	93 (200)	93 (200)	93 (200)	93 (200)	93 (200)
PVDC	54 (130)	38 (100)	38 (100)	38 (100)	38 (100)	65 (150)	65 (150)
SBR Styrene		U	U	U	U	93 (200)	93 (200)

Notes: U = unsatisfactory
XX (XX) = degrees C (degrees F)

Table B-1. Fluid/Material Matrix

FLUID/MATERIAL	Potassium Permanganate 10%	Potassium Permanganate 20%	Potassium Sulfate 10%	Propylene Glycol	Silicone Oil	Soap Solution 5%	Soap Solutions
METALS							
Aluminum	98 (210)	98 (210)	98 (210)	76 (170)	38 (100)		149 (300)
Bronze	93 (200)	26 (80)	26 (80)	98 (210)	176 (350)	176 (350)	176 (350)
Carbon Steel	26 (80)	26 (80)	98 (210)	98 (210)	38 (100)	65 (150)	76 (170)
Copper	26 (80)	26 (80)	65 (150)	32 (90)	38 (100)		26 (80)
Ductile Iron, Pearlitic							
Hastelloy C	98 (210)	98 (210)	98 (210)	32 (90)		38 (100)	32 (90)
Inconel	98 (210)	98 (210)	98 (210)	32 (90)		32 (90)	32 (90)
Monel	98 (210)	98 (210)	98 (210)	32 (90)		43 (110)	38 (100)
Nickel	98 (210)	98 (210)	98 (210)	32 (90)		65 (150)	60 (140)
304 SS	98 (210)	98 (210)	98 (210)	32 (90)	38 (100)	65 (150)	32 (90)
316 SS	175 (350)	176 (350)	176 (350)	98 (210)	38 (100)	65 (150)	32 (90)
NON-METALS							
ABS	U	32 (90)	60 (140)	32 (90)			
CPVC	87 (190)	60 (140)	82 (180)	U	87 (190)	83 (180)	82 (180)
Resins - Epoxy	65 (150)	65 (150)	121 (250)	98 (210)	26 (80)	32 (90)	
- Furan	127 (260)	71 (160)	121 (250)	121 (250)			
- Polyester	98 (210)	104 (220)	104 (220)	93 (200)		32 (90)	26 (80)
- Vinyl Ester	104 (220)	98 (210)	98 (210)	98 (210)		60 (140)	60 (140)
HDPE	60 (140)	60 (140)	60 (140)	60 (140)	60 (140)	60 (140)	60 (140)
PP	65 (150)	60 (140)	104 (220)	60 (140)	60 (140)	60 (140)	82 (180)
PTFE	243 (470)	243 (470)	243 (470)	243 (470)	243 (470)	243 (470)	243 (470)
PVC Type 2	60 (140)	32 (90)	60 (140)	U		32 (90)	26 (80)
PVDF	138 (280)	138 (280)	138 (280)	127 (260)	121 (250)	26 (80)	38 (100)
OTHER MATERIALS							
Butyl	54 (130)	54 (130)	82 (180)		U		65 (150)
EPDM	98 (210)	60 (140)	149 (300)		149 (300)	149 (300)	154 (310)
EPT	98 (210)	87 (190)	98 (210)	149 (300)	93 (200)	98 (210)	98 (210)
FEP	204 (400)	204 (400)	204 (400)	204 (400)	204 (400)	204 (400)	204 (400)
FKM	71 (160)	71 (160)	204 (400)	149 (300)	204 (400)	204 (400)	204 (400)
Borosilicate Glass	121 (250)	121 (250)	121 (250)	98 (210)		93 (200)	93 (200)
Neoprene	38 (100)	38 (100)	93 (200)	32 (90)	15 (60)	93 (200)	93 (200)
Nitrile	49 (120)	U	104 (220)	82 (180)	104 (220)	104 (220)	110 (230)
N-Rubber	U	U	65 (150)		U	65 (150)	65 (150)
PFA	93 (200)	93 (200)	93 (200)			93 (200)	98 (210)
PVDC	54 (130)	54 (130)	76 (170)			76 (170)	82 (180)
SBR Styrene						93 (200)	93 (200)

Notes: U = unsatisfactory
XX (XX) = degrees C (degrees F)

Table B-1. Fluid/Material Matrix

FLUID/MATERIAL	Sodium Aluminate	Sodium Bicarbonate 20%	Sodium Bisulfate	Sodium Carbonate	Sodium Chloride	Sodium Hydroxide 10%	Sodium Hydroxide 15%
METALS							
Aluminum	32 (90)	65 (150)	U	U	U	U	U
Bronze	U	32 (90)	38 (100)	38 (100)	98 (210)	87 (190)	98 (210)
Carbon Steel	65 (150)	38 (100)	49 (120)	49 (120)	71 (160)	98 (210)	98 (210)
Copper		26 (80)	38 (120)	38 (120)	98 (210)	98 (210)	98 (210)
Ductile Iron, Pearlitic		30 (86)			82 (180)	50 (122)	
Hastelloy C	65 (150)	98 (210)	98 (210)	98 (210)	98 (210)	109 (230)	98 (210)
Inconel		98 (210)	98 (210)	98 (210)	98 (210)	149 (300)	98 (210)
Monel	65 (150)	98 (210)	98 (210)	98 (210)	98 (210)	176 (350)	176 (350)
Nickel		98 (210)	98 (210)	98 (210)	98 (210)	98 (210)	209 (410)
304 SS	26 (80)	121 (250)	98 (210)	98 (210)	98 (210)	98 (210)	98 (210)
316 SS	60 (140)	176 (350)	176 (350)	176 (350)	176 (350)	176 (350)	149 (300)
NON-METALS							
ABS		60 (140)	60 (140)	60 (140)	60 (140)	60 (140)	60 (140)
CPVC		98 (210)	98 (210)	98 (210)	98 (210)	87 (190)	82 (180)
Resins - Epoxy		121 (250)	149 (300)	149 (300)	98 (210)	87 (190)	93 (200)
- Furan		127 (260)	127 (260)	127 (260)	127 (260)	U	U
- Polyester	65 (150)	71 (160)	71 (160)	71 (160)	104 (220)	54 (130)	65 (150)
- Vinyl Ester	65 (150)	93 (200)	82 (180)	82 (180)	82 (180)	76 (190)	65 (150)
HDPE		60 (140)	60 (140)	60 (140)	60 (140)	60 (140)	76 (170)
PP		104 (220)	104 (220)	104 (220)	104 (220)	104 (220)	98 (210)
PTFE	149 (300)	243 (470)	243 (470)	243 (470)	243 (470)	243 (470)	243 (470)
PVC Type 2		60 (140)	60 (140)	60 (140)	60 (140)	60 (140)	60 (140)
PVDF		138 (280)	138 (280)	138 (280)	138 (280)	98 (210)	98 (210)
OTHER MATERIALS							
Butyl		82 (180)	82 (180)	82 (180)	82 (180)	82 (180)	82 (180)
EPDM	93 (200)	149 (300)	149 (300)	149 (300)	149 (300)	149 (300)	149 (300)
EPT		82 (180)	82 (180)	82 (180)	82 (180)	98 (210)	98 (210)
FEP	38 (100)	204 (400)	204 (400)	204 (400)	204 (400)	204 (400)	204 (400)
FKM	93 (200)	204 (400)	87 (190)	87 (190)	204 (400)	15 (60)	15 (60)
Borosilicate Glass		121 (250)	121 (250)	121 (250)	121 (250)	U	U
Neoprene	65 (150)	93 (200)	93 (200)	93 (200)	93 (200)	93 (200)	93 (200)
Nitrile	82 (180)	104 (220)	93 (200)	93 (200)	109 (230)	71 (160)	71 (160)
N-Rubber		65 (150)	82 (180)	82 (180)	54 (130)	65 (150)	65 (150)
PFA		93 (200)	93 (200)	93 (200)	93 (200)	121 (250)	121 (250)
PVDC		82 (180)	82 (180)	82 (180)	82 (180)	32 (90)	32 (90)
SBR Styrene					93 (200)		U

Notes: U = unsatisfactory
XX (XX) = degrees C (degrees F)

Table B-1. Fluid/Material Matrix

FLUID/MATERIAL	Sodium Hydroxide 30%	Sodium Hydroxide 50%	Sodium Hydroxide 70%	Sodium Hydroxide Soln. (Conc.)	Sodium Hypochlorite 20%	Sodium Hypochlorite (Conc.)	Sodium Hyposulfite 5%
METALS							
Aluminum	U	U	U	U	26 (80)	U	
Bronze	38 (100)	60 (140)	32 (90)	26 (80)	26 (80)	U	
Carbon Steel	98 (210)	38 (100)	98 (210)	143 (290)	U	U	
Copper	32 (90)	60 (140)	65 (150)	26 (80)	26 (80)	U	32 (90)
Ductile Iron, Pearlitic		127 (260)	127 (260)				
Hastelloy C	98 (210)	98 (210)	104 (220)	49 (120)	U	54 (130)	32 (90)
Inconel	149 (300)	149 (300)	98 (210)	26 (80)	U	U	26 (80)
Monel	98 (210)	149 (300)	143 (290)	176 (350)	26 (80)	U	26 (80)
Nickel	149 (300)	149 (300)	98 (210)	93 (200)	U	U	26 (80)
304 SS	98 (210)	98 (210)	109 (230)	32 (90)	U	26 (80)	U
316 SS	98 (210)	176 (350)	109 (230)	176 (350)	U	26 (80)	U
NON-METALS							
ABS	60 (140)	60 (140)	60 (140)	60 (140)	60 (140)	60 (140)	
CPVC	82 (180)	82 (180)	82 (180)	87 (190)	87 (190)	82 (180)	
Resins - Epoxy	93 (200)	93 (200)	121 (250)		26 (80)		
- Furan	U	U	127 (260)	U	U	U	
- Polyester	65 (150)	104 (220)			U	60 (140)	82 (180)
- Vinyl Ester	65 (150)	104 (220)	U		82 (180)	38 (100)	98 (210)
HDPE	76 (170)	76 (170)	60 (140)		60 (140)	60 (140)	60 (140)
PP	98 (210)	104 (220)	104 (220)	60 (140)	49 (120)	43 (110)	
PTFE	243 (470)	243 (470)	243 (470)	243 (470)	243 (470)	243 (470)	243 (470)
PVC Type 2	60 (140)	60 (140)	60 (140)	60 (140)	60 (140)	60 (140)	
PVDF	98 (210)	104 (220)	71 (160)	65 (150)	138 (280)	138 (280)	127 (260)
OTHER MATERIALS							
Butyl	82 (180)	87 (190)	82 (180)		54 (130)	32 (90)	
EPDM	154 (310)	149 (300)	149 (300)	149 (300)	71 (160)	60 (140)	60 (140)
EPT	98 (210)	93 (200)	87 (190)	26 (80)	U	U	
FEP	204 (400)	204 (400)	204 (400)	204 (400)	204 (400)	204 (400)	204 (400)
FKM	15 (60)	15 (60)	15 (60)	15 (60)	193 (380)	204 (400)	82 (180)
Borosilicate Glass	U	U	U	U	121 (250)	65 (140)	121 (250)
Neoprene	93 (200)	93 (200)	93 (200)	93 (200)	U	U	
Nitrile	71 (160)	65 (150)	71 (160)	65 (150)	U	U	
N-Rubber	65 (150)	65 (150)	65 (140)	65 (140)	32 (90)	32 (90)	
PFA	121 (250)	121 (250)	26 (80)		93 (200)		
PVDC	60 (140)	65 (150)	54 (80)	U	54 (130)	49 (120)	
SBR Styrene	U	U	U	U			

Notes: U = unsatisfactory
XX (XX) = degrees C (degrees F)

Table B-1. Fluid/Material Matrix

FLUID/MATERIAL	Sodium Nitrate	Sodium Phosphate Acid	Sodium Phosphate Alkaline	Sodium Phosphate Neutral	Sodium Sulfite 10%	Sour Crude Oil	Sulfonated Detergents
METALS							
Aluminum	176 (350)	U	U	U	98 (210)		
Bronze	38 (100)	98 (210)	32 (90)	98 (210)	U		
Carbon Steel	65 (150)		65 (150)		26 (80)		
Copper	43 (110)	26 (80)	32 (90)	32 (90)	26 (80)		
Ductile Iron, Pearlitic							
Hastelloy C	32 (90)	98 (210)	98 (210)	98 (210)	98 (210)	65 (150)	65 (150)
Inconel	93 (200)	98 (210)	98 (210)	98 (210)	98 (210)		
Monel	98 (210)	98 (210)	98 (210)	98 (210)	98 (210)		
Nickel	98 (210)	98 (210)	98 (210)	98 (210)	98 (210)		
304 SS	98 (210)	98 (210)	98 (210)	98 (210)	98 (210)		
316 SS	176 (350)	98 (210)	98 (210)	98 (210)	98 (210)		
NON-METALS							
ABS	60 (140)	60 (140)			60 (140)		
CPVC	82 (180)	76 (170)	82 (180)	82 (180)	82 (180)	87 (190)	76 (170)
Resins - Epoxy	149 (300)	U	U	U	121 (250)	87 (190)	121 (250)
- Furan	71 (160)	121 (250)		U	121 (250)		121 (250)
- Polyester	104 (220)	98 (210)			93 (200)	104 (220)	93 (200)
- Vinyl Ester	98 (210)	109 (320)	98 (210)	98 (210)	98 (210)	127 (260)	98 (210)
HDPE	60 (140)	32 (90)	26 (80)	26 (80)	60 (140)	26 (80)	
PP	98 (210)	93 (200)	98 (210)	93 (200)	60 (140)	65 (150)	49 (120)
PTFE	243 (470)	243 (470)	243 (470)	243 (470)	243 (470)	243 (470)	243 (470)
PVC Type 2	60 (140)	60 (140)				60 (140)	
PVDF	138 (280)	138 (280)	138 (280)	138 (280)	138 (280)	138 (280)	
OTHER MATERIALS							
Butyl	82 (180)	93 (200)	82 (180)	93 (200)	87 (190)		
EPDM	138 (280)	98 (210)	98 (210)	98 (210)	60 (140)	U	
EPT	82 (180)	98 (210)	98 (210)	98 (210)	98 (210)	U	
FEP	204 (400)	204 (400)	204 (400)	204 (400)	204 (400)	204 (400)	204 (400)
FKM	15 (60)	87 (190)	82 (180)	87 (190)	87 (190)	U	
Borosilicate Glass	121 (250)	98 (210)	93 (200)	98 (210)	U		98 (210)
Neoprene	93 (200)	60 (140)	93 (200)	60 (140)	87 (190)		
Nitrile	65 (150)	82 (180)	93 (200)	82 (180)	87 (190)	60 (140)	
N-Rubber	65 (150)	71 (160)	71 (160)	71 (160)	65 (150)		
PFA	93 (200)	93 (200)	93 (200)	93 (200)	93 (200)	93 (200)	
PVDC	65 (150)	65 (150)	65 (150)	65 (150)	65 (150)	65 (150)	
SBR Styrene							

Notes: U = unsatisfactory
XX (XX) = degrees C (degrees F)

Table B-1. Fluid/Material Matrix

FLUID/MATERIAL	Sulfuric Acid 10%	Sulfuric Acid 30%	Sulfuric Acid 50%	Sulfuric Acid 60%	Sulfuric Acid 70%	Sulfuric Acid 80%	Sulfuric Acid 90%
METALS							
Aluminum	U	U	U	U	U	U	U
Bronze	U	U	U	U	U	U	U
Carbon Steel	U	U	U	U	U	U	U
Copper	U	U	U	U	U	U	U
Ductile Iron, Pearlitic						32 (90)	
Hastelloy C	98 (210)	87 (190)	109 (230)	127 (260)	93 (200)	116 (240)	87 (190)
Inconel	U	U	U	U	U	U	U
Monel	26 (80)	26 (80)	49 (120)	54 (130)	26 (80)	26 (80)	U
Nickel	26 (80)	26 (80)	32 (90)	32 (90)	U	U	U
304 SS	U	U	U	U	U	32 (90)	26 (80)
316 SS	U	U	U	U	U	43 (110)	26 (80)
NON-METALS							
ABS	60 (140)	32 (90)	54 (130)	U	U	U	U
CPVC	82 (180)	82 (180)	82 (180)	87 (190)	93 (200)	116 (240)	U
Resins - Epoxy	60 (140)	49 (1230)	43 (110)	43 (110)	43 (110)	U	U
- Furan	121 (250)	121 (250)	127 (260)	121 (250)	127 (260)	U	U
- Polyester	104 (220)	104 (220)	104 (220)	71 (160)	71 (160)	U	U
- Vinyl Ester	93 (200)	82 (180)	98 (210)	87 (190)	82 (180)	U	U
HDPE	60 (140)	60 (140)	60 (140)	26 (80)	26 (80)	U	U
PP	93 (200)	93 (200)	93 (200)	98 (210)	82 (180)	76 (170)	82 (180)
PTFE	243 (470)	243 (470)	243 (470)	243 (470)	243 (470)	243 (470)	243 (470)
PVC Type 2	60 (140)	60 (140)	60 (140)	60 (140)	60 (140)	U	U
PVDF	121 (240)	104 (220)	104 (220)	116 (240)	104 (220)	93 (200)	98 (210)
OTHER MATERIALS							
Butyl	82 (180)	82 (180)	65 (150)		38 (100)	38 (100)	U
EPDM	60 (140)	60 (140)	60 (140)		60 (140)	15 (60)	U
EPT	93 (200)	60 (140)	98 (210)		98 (210)	38 (100)	26 (80)
FEP	204 (400)	204 (400)	204 (400)	204 (400)	204 (400)	204 (400)	204 (400)
FKM	176 (350)	176 (350)	176 (350)		176 (350)	176 (350)	176 (350)
Borosilicate Glass	204 (400)	204 (400)	204 (400)	204 (400)	204 (400)	204 (400)	204 (400)
Neoprene	93 (200)	93 (200)	93 (200)		93 (200)	U	U
Nitrile	60 (140)	60 (140)	93 (200)		U	15 (60)	U
N-Rubber	65 (150)	65 (150)	38 (100)		U	U	U
PFA	121 (250)	121 (250)	121 (250)	121 (250)	121 (250)	121 (250)	121 (250)
PVDC	49 (120)	26 (80)	U	U	U	U	U
SBR Styrene	U	U	U		U	U	U

Notes: U = unsatisfactory
XX (XX) = degrees C (degrees F)

Table B-1. Fluid/Material Matrix

FLUID/MATERIAL	Sulfuric Acid 95%	Sulfuric Acid 98%	Sulfuric Acid 100%	Sulfuric Acid 103%	Sulfuric Acid, Fuming	Sulfurous Acid	Tetrachloroethane
METALS							
Aluminum	U	U	U		32 (90)	187 (370)	15 (60)
Bronze	U	U	U		U	U	
Carbon Steel	32 (90)	38 (100)	43 (110)			U	26 (80)
Copper		U	U		U	38 (100)	15 (60)
Ductile Iron, Pearlitic	49 (120)	121 (250)	163 (325)				
Hastelloy C	143 (290)	98 (210)	87 (190)		32 (90)	187 (370)	71 (160)
Inconel	U	U	U	U	U	32 (90)	
Monel	U	U	U	U	U	U	
Nickel	U	U	U		U	U	
304 SS	32 (90)	26 (80)	26 (80)	U	32 (90)	U	26 (80)
316 SS	98 (210)	98 (210)	98 (210)	32 (90)	98 (210)	65 (150)	15 (60)
NON-METALS							
ABS	U	U	U	U	U	60 (140)	
CPVC	U	U	U	U	15 (60)	82 (180)	U
Resins - Epoxy	U	U	U	U	U	116 (240)	32 (90)
- Furan	U	U	U		U	71 (160)	71 (160)
- Polyester	U	U				43 (110)	
- Vinyl Ester	U	U	U	U	U	49 (120)	49 (120)
HDPE	U	U	U	U	U	60 (140)	U
PP	15 (60)	49 (120)	U	U	U	82 (180)	15 (60)
PTFE	243 (470)	243 (470)	243 (470)	243 (470)	243 (470)	243 (470)	243 (470)
PVC Type 2	U	U	U	U	U	60 (140)	U
PVDF	98 (210)	60 (140)	U	U	U	121 (250)	121 (250)
OTHER MATERIALS							
Butyl	U	U	U	U		65 (150)	
EPDM	U	U	U	U	U	U	U
EPT	U	U	U	U		82 (180)	U
FEP	204 (400)	204 (400)	204 (400)	204 (400)	204 (400)	216 (420)	204 (400)
FKM	176 (350)	198 (390)	87 (190)		93 (200)	204 (400)	93 (200)
Borosilicate Glass	204 (400)	204 (400)	204 (400)	204 (400)		109 (230)	
Neoprene	U	U	U	U	U	U	U
Nitrile	U	U		U	U	15 (60)	U
N-Rubber	U	U	U	U		U	U
PFA	121 (250)	93 (200)			26 (80)	98 (210)	
PVDC	U	U	U	U	U	26 (80)	
SBR Styrene	U	U	U	U	U		U

Notes: U = unsatisfactory
XX (XX) = degrees C (degrees F)

Table B-1. Fluid/Material Matrix

FLUID/MATERIAL	Tetrachloroethylene	Thread Cutting Oil	Toluene	Transformer Oil	Transformer Oil DTE/30	1,1,1 Trichloroethane	Trichloroethylene
METALS							
Aluminum	98 (210)		98 (210)	26 (80)	65 (150)		149 (300)
Bronze	32 (90)		176 (350)	32 (90)	65 (150)		26 (80)
Carbon Steel		82 (180)	176 (350)	26 (80)	65 (150)	26 (80)	26 (80)
Copper	32 (90)		98 (210)				26 (80)
Ductile Iron, Pearlitic							
Hastelloy C			98 (210)	32 (90)	65 (150)		98 (210)
Inconel			98 (210)				98 (210)
Monel			98 (210)	32 (90)	65 (150)		187 (370)
Nickel			98 (210)	32 (90)			98 (210)
304 SS		65 (150)	98 (210)	32 (90)		32 (90)	98 (210)
316 SS		65 (150)	176 (350)	32 (90)	65 (150)		187 (370)
NON-METALS							
ABS	U		U			U	U
CPVC	U	38 (100)	U	82 (180)	82 (180)	U	U
Resins - Epoxy	U		65 (150)	109 (230)			60 (140)
- Furan	121 (250)		127 (260)			26 (80)	82 (180)
- Polyester	43 (110)		U	104 (220)			U
- Vinyl Ester	49 (120)		49 (120)	149 (300)		U	U
HDPE	U		U	60 (140)	60 (140)	U	U
PP	U	49 (120)	15 (60)	43 (110)	65 (150)	U	15 (60)
PTFE	243 (470)	243 (470)	243 (470)	243 (470)	149 (300)	243 (470)	243 (470)
PVC Type 2	U		U			U	U
PVDF	121 (250)	93 (200)	98 (210)			49 (120)	127 (260)
OTHER MATERIALS							
Butyl			U	U			U
EPDM	U	U	U	U	U	U	U
EPT	U	U	U	U		U	U
FEP	204 (400)	204 (400)	204 (400)	204 (400)		204 (400)	204 (400)
FKM	204 (400)		204 (400)	204 (400)		26 (80)	204 (400)
Borosilicate Glass		98 (210)	121 (250)	32 (90)		93 (200)	132 (370)
Neoprene			U	54 (130)	U	U	U
Nitrile	U	15 (60)	65 (150)	104 (220)	60 (140)	U	U
N-Rubber			U	U			U
PFA	93 (200)		98 (210)	93 (200)			93 (200)
PVDC		49 (120)	28 (80)			32 (90)	26 (80)
SBR Styrene			U	U			U

Notes: U = unsatisfactory
XX (XX) = degrees C (degrees F)

Table B-1. Fluid/Material Matrix

FLUID/MATERIAL	Turpentine	Water, Acid Mine	Water, Demineralized	Water, Distilled	Water, Potable	Water, Salt	Water, Sea
METALS							
Aluminum	87 (190)	U	82 (180)	U	98 (210)	U	38 (100)
Bronze	176 (350)	U		93 (200)	98 (210)	121 (250)	121 (250)
Carbon Steel	26 (80)	U	U	U		26 (80)	32 (90)
Copper	26 (80)	U		32 (90)	98 (210)	26 (80)	26 (80)
Ductile Iron, Pearlitic					30 (86)	32 (90)	32 (90)
Hastelloy C	38 (100)	32 (90)	93 (200)	298 (570)	98 (210)	149 (300)	298 (570)
Inconel	26 (80)	32 (90)	60 (140)	15 (60)		26 (80)	26 (80)
Monel	43 (110)			U	98 (210)	121 (250)	121 (250)
Nickel	26 (80)	U	93 (200)	26 (80)		26 (80)	32 (90)
304 SS	93 (200)	49 (120)	227 (440)	121 (250)	98 (210)	26 (80)	26 (80)
316 SS	176 (340)	49 (120)	227 (440)	121 (250)	98 (210)	121 (250)	121 (250)
NON-METALS							
ABS	U	60 (140)	60 (140)	60 (140)	26 (80)	60 (140)	32 (90)
CPVC	60 (140)	82 (180)	82 (180)	82 (180)	98 (210)	82 (180)	82 (180)
Resins - Epoxy	65 (150)	149 (300)	121 (250)	98 (210)		98 (210)	149 (300)
- Furan			121 (250)	93 (200)			121 (250)
- Polyester	26 (80)		71 (160)	93 (200)	98 (210)	82 (180)	104 (220)
- Vinyl Ester	65 (150)	98 (210)	98 (210)	98 (210)	98 (210)	82 (180)	82 (180)
HDPE	U	60 (140)	60 (140)	60 (140)		60 (140)	60 (140)
PP	26 (80)	104 (220)	104 (220)	104 (220)	82 (180)	104 (220)	104 (220)
PTFE	243 (470)	243 (470)	243 (470)	243 (470)	204 (400)	243 (470)	243 (470)
PVC Type 2	U	60 (140)	60 (140)	60 (140)	60 (140)	60 (140)	60 (140)
PVDF	138 (280)	104 (220)	138 (280)	138 (280)	138 (280)	138 (280)	138 (280)
OTHER MATERIALS							
Butyl	U		60 (140)			87 (190)	
EPDM	U	93 (200)	121 (250)	149 (300)	121 (250)	121 (250)	121 (250)
EPT	U	98 (210)	98 (210)	98 (210)		93 (200)	93 (200)
FEP	204 (400)	204 (400)	204 (400)	204 (400)		204 (400)	204 (400)
FKM	209 (410)	87 (290)	87 (190)	87 (190)	149 (300)	87 (190)	87 (190)
Borosilicate Glass	121 (250)	98 (210)		121 (250)	98 (210)	98 (210)	98 (210)
Neoprene	U	98 (210)	98 (210)	93 (200)	82 (180)	98 (210)	98 (210)
Nitrile	104 (220)	98 (210)	98 (210)	98 (210)	82 (180)	98 (210)	98 (210)
N-Rubber	U		65 (150)	65 (150)		65 (150)	
PFA	93 (200)	93 (200)	93 (200)	93 (200)		93 (200)	93 (200)
PVDC	49 (120)	82 (180)	76 (170)	76 (170)	76 (170)	82 (180)	76 (170)
SBR Styrene	U	93 (200)	98 (210)	93 (200)		93 (200)	93 (200)

Notes: U = unsatisfactory
 XX (XX) = degrees C (degrees F)

Table B-1. Fluid/Material Matrix

FLUID/MATERIAL	Water, Sewage	Xylene	Zinc Chloride		
METALS					
Aluminum		93 (200)	U		
Bronze	32 (90)	121 (250)	U		
Carbon Steel	32 (90)	93 (200)	U		
Copper	32 (90)	93 (200)	U		
Ductile Iron, Pearlitic			U		
Hastelloy C		149 (300)	121 (250)		
Inconel		93 (200)	26 (80)		
Monel		39 (200)	93 (200)		
Nickel		93 (200)	93 (200)		
304 SS	32 (90)	93 (200)	U		
316 SS	32 (90)	93 (200)	93 (200)		
NON-METALS					
ABS	26 (80)	U	60 (140)		
CPVC	82 (180)	U	82 (180)		
Resins - Epoxy		60 (140)	121 (250)		
- Furan		127 (260)	127 (260)		
- Polyester		32 (90)	121 (250)		
- Vinyl Ester		60 (140)	82 (180)		
HDPE	60 (140)	U	60 (140)		
PP	104 (220)	15 (60)	93 (200)		
PTFE	243 (470)	243 (470)	243 (470)		
PVC Type 2	60 (140)	U	60 (140)		
PVDF	121 (250)	98 (210)	127 (260)		
OTHER MATERIALS					
Butyl		U	87 (190)		
EPDM	98 (210)	U	149 (300)		
EPT	60 (140)	U	82 (160)		
FEP	204 (400)	227 (440)	204 (400)		
FKM	87 (190)	204 (400)	204 (400)		
Borosilicate Glass		121 (250)	98 (210)		
Neoprene	71 (160)	U	71 (160)		
Nitrile	87 (190)	U	104 (220)		
N-Rubber		U	65 (150)		
PFA	93 (200)	93 (200)	93 (200)		
PVDC	76 (170)	U	76 (170)		
SBR Styrene		U			

Notes: U = unsatisfactory
 XX (XX) = degrees C (degrees F)

Appendix C
Design Example

The following paragraphs present an example design that utilizes the material and information contained in Chapters 1 through 12, and Appendix B. The calculations and assumptions are specific to the example conditions presented, and may not necessarily represent conditions at an actual, specific site.

C-1. Design Example

A facility requires an upgrade and retrofit to their existing wastewater pretreatment system. The pretreatment system is required to reduce the dissolved metal content of two process waste waters before introduction into a biologically based central treatment plant. Due to process changes over the years and reduced effluent limits, the existing pretreatment facility no longer removes enough metals to consistently meet effluent requirements.

The waste waters are produced from a plating process (Process A) and from the finishing stages of a metal fabrication facility (Process B). The latter could include

metal cleaning using organic solvents and painting operations. The retrofit is to include the renovation and splitting of an existing, covered, concrete wetwell (P1560). Half of the wetwell will now act as an influent wetwell (P1560) to a new treatment train and the other half will act as the clearwell (P1510) for the effluent from the new treatment system. The new treatment system will include a low-profile air stripper to reduce solvent concentrations followed by a ferrous-based precipitation reactor and associated flocculation tank and clarifier. Figure C-1 is the flow diagram of the proposed pretreatment system renovation, and Figure C-2 is the piping and instrumentation diagram. Figure C-3 is the general equipment arrangement with the anticipated piping layout.

The influent to the pretreatment system averages $3.79 \times 10^{-3} \text{ m}^3/\text{s}$ with a maximum future flow of $5.36 \times 10^{-3} \text{ m}^3/\text{s}$ and a process temperatures of 16°C-minimum, 23.9°C-normal, and 46°C-maximum. The average pH is 5.4 due to the presence of chromic and sulfuric acids, although occasional upsets have produced pH as low as 3.6. The pollutant concentrations are summarized in Table C-1.

Table C-1
Pollutant Concentrations

Parameter	Maximum (mg/l)	Average (mg/l)
Total Cyanide	0.368	0.078
Chromium	80.2	24.9
Nickel	74.9	15.3
Copper	6.29	0.71
Zinc	10.3	0.88
Lead	12.8	1.57
Silver	0.84	0.21
Cadmium	3.24	0.77
Xylene	210	53.2
Toluene	180	45.1
111-Trichloroethylene	500	48.3
Ethyl Ether	54.3	15.2

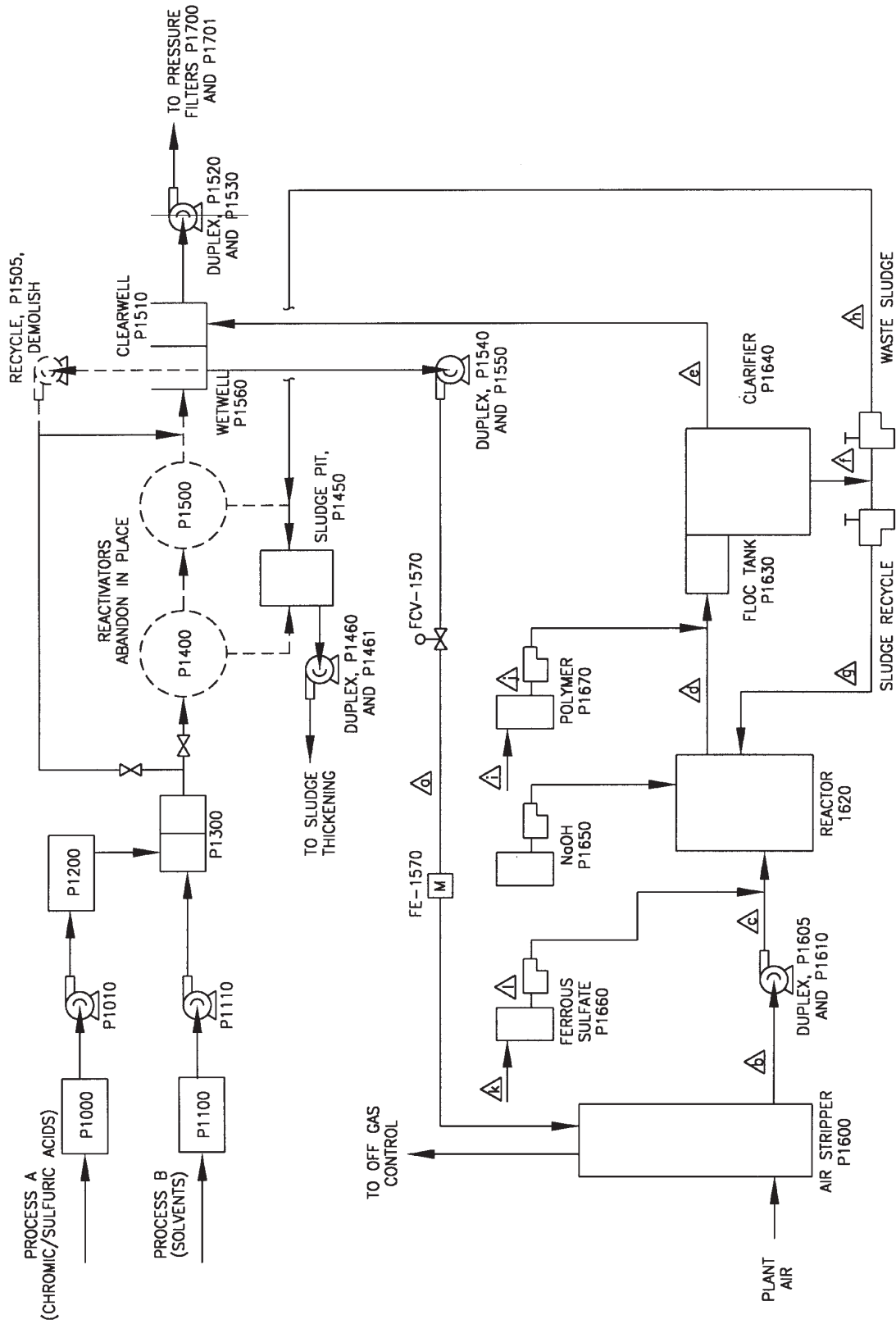

Figure C-1. Design Example Process Flow Diagram
(Process Conditions Table continued on next page)

Table C-2
Process Conditions, Design Example Process
Flow Diagram, Continued

Point	Line Designation	Normal			Maximum			Minimum		
		Flow (m ³ /s x 10 ⁻³)	Temp. (°C)	Pressure (kPa)	Flow (m ³ /s x 10 ⁻³)	Temp. (°C)	Pressure (kPa)	Flow (m ³ /s x 10 ⁻³)	Temp. (°C)	Pressure (kPa)
a	XXX-INF-1500	3.79	23.9	tbd	5.36	46.0	tbd	3.79	16.0	tbd
b	XXX-IAS-1600	3.79	23.9	tbd	5.36	46.0	tbd	3.79	16.0	tbd
c	XXX-IAS-1620	3.79	23.9	tbd	5.36	46.0	tbd	3.79	16.0	tbd
d	XXX-PRI-1630	3.79	23.9	gravity flow	5.36	46.0	gravity flow	3.79	16.0	gravity flow
e	XXX-EFF-1640	3.79	23.9	gravity flow	5.36	46.0	gravity flow	3.79	16.0	gravity flow
f	XXX-SLG-1650	2.30	23.9	250	2.75	46.0	250	2.30	16.0	250
g	XXX-SLG-1651	0.36	23.9	250	2.75	46.0	250	0.36	16.0	250
h	XXX-SLG-1660	1.94	23.9	250	2.75	46.0	250	1.94	16.0	250
I	XXX-PYS-101	0.438	23.9	tbd	0.438	46.0	79.5	0.438	16.0	tbd
j	XXX-PYS-102	0.00105	23.9	tbd	0.00131	46.0	79.5	0.00105	16.0	tbd
k	XXX-FES-111	0.842	23.9	tbd	0.842	46.0	79.5	0.842	16.0	tbd
l	XXX-FES-112	0.0105	23.9	tbd	0.0131	46.0	79.5	0.0105	16.0	tbd

Notes:

XXX - line size to be determined in calculations

tbd - to be determined

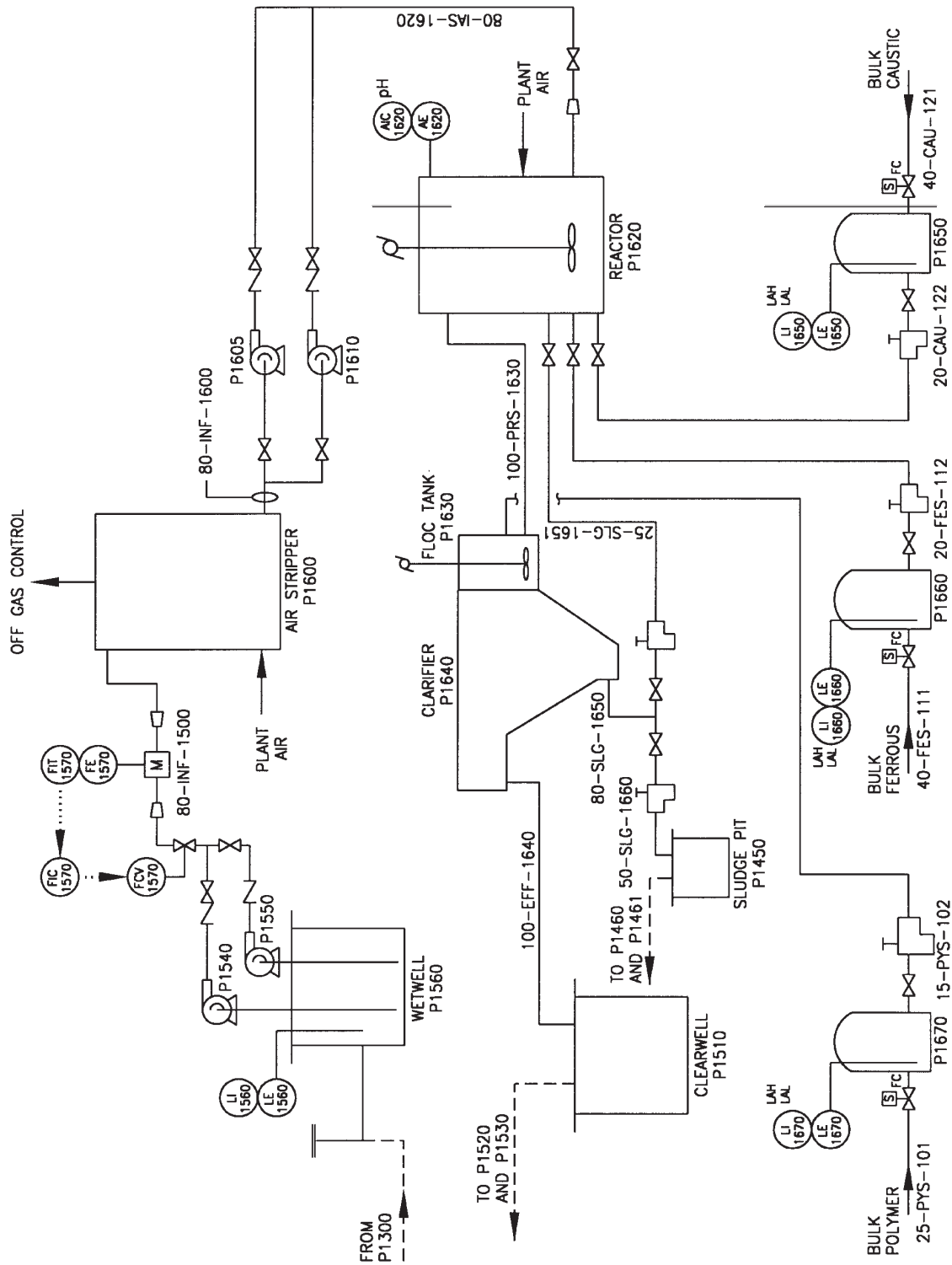

Figure C-2. Design Example Piping and Instrumentation Diagram

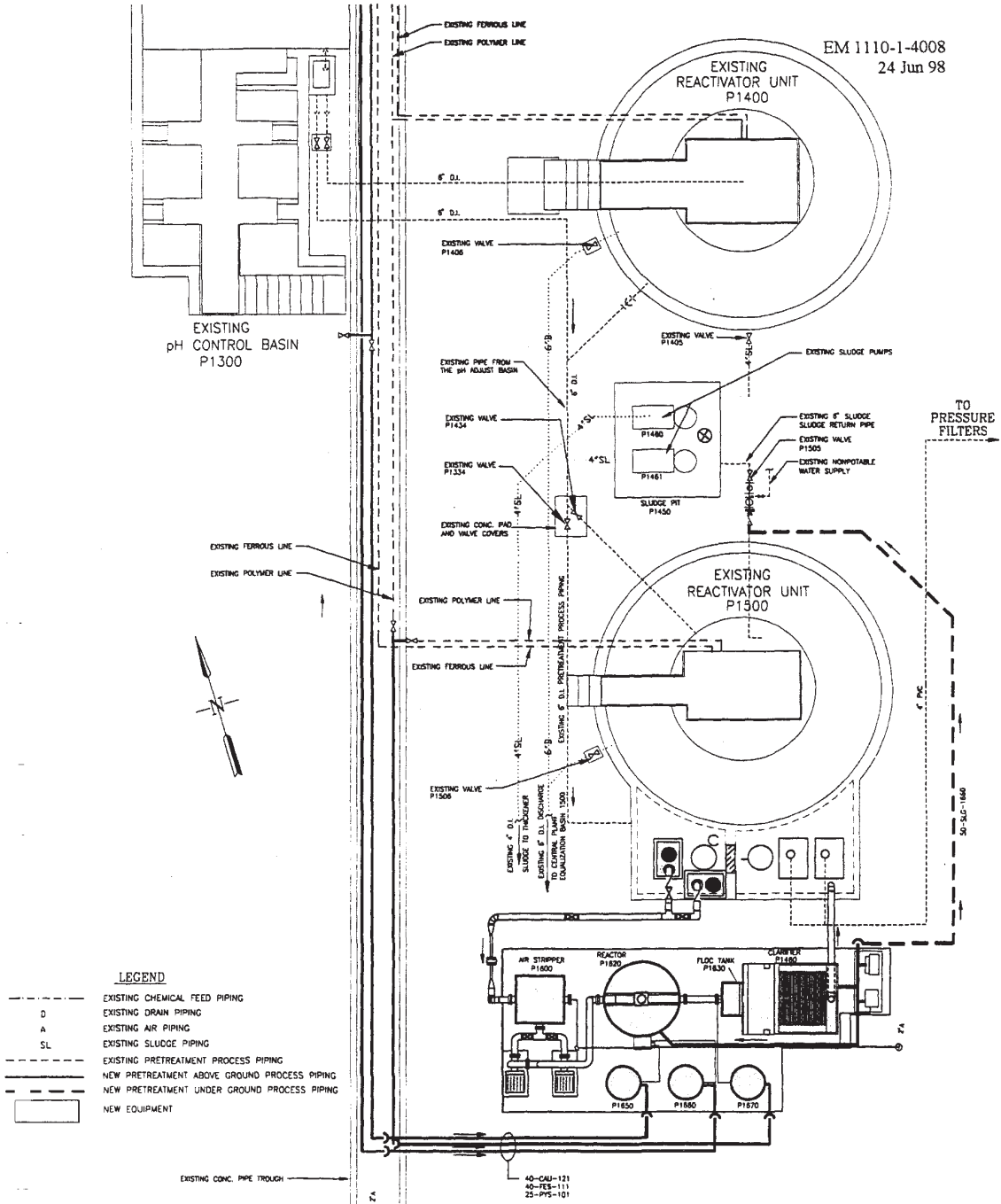
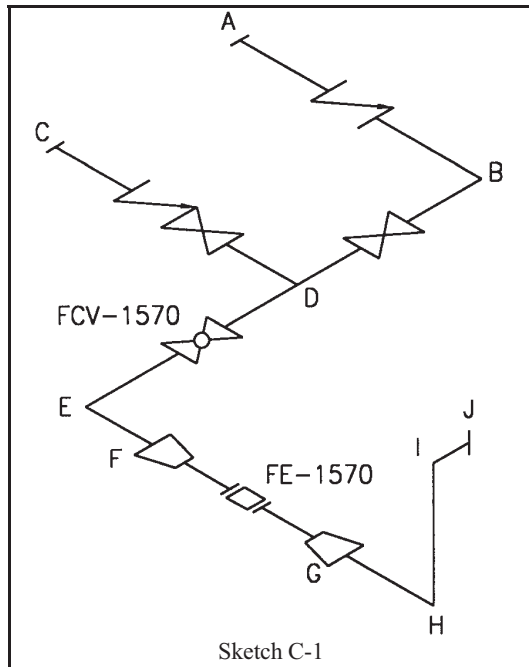

Figure C-3. Piping Layout Plan

C-2. Solution

- a. **Line XXX-INF-1500**
 Influent from Wetwell P1560 to Air Stripper P1600



Flow is either through A-D or C-D, but not both simultaneously

Maximum Flowrate, $Q = 5.36 \times 10^{-3} \text{ m}^3/\text{s}$

Elevation Change (H-I) = 2.44 m (= 23.9 kPa head)

Total run
 = 7.84 m for A-J
 = 7.33 m for C-J

Fittings (identical for either A-J or C-J)
 1 swing check valve
 1 gate valve (isolation)
 1 flow control valve
 1 reducer
 1 expansion

MATERIAL OF CONSTRUCTION

Referring to the fluid/material matrix in Appendix B, the potential for mixed acids eliminates aluminum, bronze, copper, carbon steel and stainless steel alloys; and the solvent content in the wastewater eliminates ABS, PVC, CPVC, HDPE and FRP. Similarly, examining the potential use of lined piping, the solvents eliminate rubber, PP and PVDC. However, PTFE and PVDF liners are acceptable.

The design specifications shall be developed to allow a liner of either PVDF, minimum thickness of 4.45 mm (confirm with pipe sizing), or PTFE (to be provided with weep vents) and a carbon steel shell of ASTM A 106, Grade A. The shell is to be joined with chamfered threaded flanges. The PVDF liner is selected for the example calculations.

PIPE SIZING/PRESSURE DROP

Step 1. Select pipe size by dividing the volumetric flowrate by the desired velocity (normal service, $V = 2.1 \text{ m/s}$ with the mid-range preferred for most applications).

$$A = \pi \frac{D_i^2}{4} = \frac{Q}{V}$$

$$D_i = \left[\frac{4}{\pi} \frac{(5.36 \times 10^{-3}) \text{ m}^3/\text{s}}{2.1 \text{ m/s}} \right]^{0.5} \left(1000 \frac{\text{mm}}{\text{m}} \right)$$

$$= 57 \text{ mm}$$

Step 2. From Table 1-1, the next largest nominal diameter is 65 mm. The commercial availability of 65 mm lined pipe is checked (65 mm is not a commonly used pipe size). This size is not available except through special order. The size choices are 50 mm or 80 mm.

50 mm pipe: From Table 9-8, a PVDF thickness of 4.37 mm is required to prevent permeation.

$$D_i = 50 \text{ mm} - (4.37 \text{ mm})(2) = 41.3 \text{ mm}$$

$$V = \frac{Q}{A} = \frac{Q}{\frac{\pi}{4} D_i^2}$$

$$= \frac{5.36 \times 10^{-3} \text{ m}^3/\text{s}}{\frac{\pi}{4} (0.0413 \text{ m})^2} = 4.0 \text{ m/s}$$

The actual velocity, 4.0 m/s, > the acceptable range, 2.1 ± 0.9 m/s. Therefore, the 50 mm pipe size is rejected.

80 mm pipe: From Table 9-8, a PVDF thickness of 4.45 mm is required to prevent permeation.

$$D_i = 80 \text{ mm} - (4.45 \text{ mm})(2) = 71.1 \text{ mm}$$

$$V = \frac{Q}{A} = \frac{Q}{\frac{\pi}{4} D_i^2}$$

$$= \frac{5.36 \times 10^{-3} \text{ m}^3/\text{s}}{\frac{\pi}{4} (0.0711 \text{ m})^2} = 1.35 \text{ m/s}$$

The actual velocity, 1.35 m/s, is within the acceptable range, 2.1 ± 0.9 m/s.

Therefore, the 80 mm PVDF lined pipe is specified and $D_i = 71.1$ mm, $D = 90$ mm and the structural wall thickness = 5 mm. The line designation is amended to: 80-INF-1500.

In addition, a pipe reduction is required to accommodate a magnetic flowmeter. From an instrument vendor nomograph over the process flow range, the magmeter should have a 40 mm bore with minimum straight, unobstructed runs of $3 \times D_i$ upstream and $2 \times D_i$ downstream. From lined piping catalogs, lined piping typically has a minimum section length. For 40 mm pipe, one vendor has fixed flange spools available with a minimum length of 819 mm. Use a 80 mm by 40 mm concentric reducer/expansion at one end of each straight pipe run; see Sketch C-2.

The actual velocity through the reduced section is required for pressure drop calculations. From Table 9-8, a PVDF thickness of 4.07 mm is required to prevent permeation.

$$D_i = 40 \text{ mm} - (4.07 \text{ mm})(2) = 31.9 \text{ mm}$$

$$V = \frac{Q}{A} = \frac{Q}{\frac{\pi}{4} D_i^2}$$

$$= \frac{5.36 \times 10^{-3} \text{ m}^3/\text{s}}{\frac{\pi}{4} (0.0319 \text{ m})^2} = 6.71 \text{ m/s}$$

The 40 mm spools have a length of 819 mm which equals $25.7 \times D_i$. Therefore, the minimum unobstructed run requirement for the meter is satisfied.

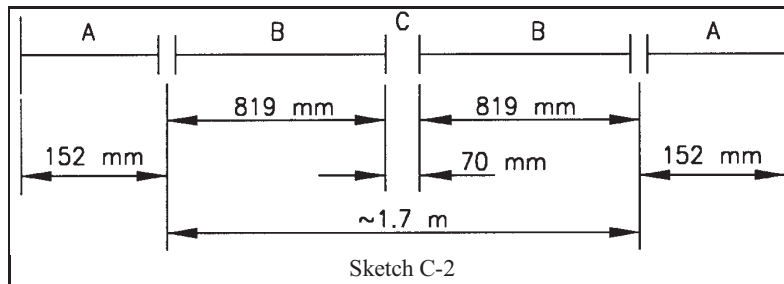

Notes:

A= identical 80 mm by 40 mm concentric reducers, $\beta = 0.5$, $\phi = 7.56^\circ$ B = identical 40 mm spools with flanged ends, 819 mm length C = wafer style magmeter, lay length is 70 mm.

Step 3. At 23.9°C , $v = 8.94 \times 10^{-7} \text{ m}^2/\text{s}$ and the Darcy-Weisbach equation is used to calculate the pressure drop through the piping.

Ref. p. 3-8.

$$h_L = \left[\left(\frac{fL}{D_i} + \Sigma K \right) \frac{V^2}{2g} \right]_{80 \text{ mm}} + \left[\left(\frac{fL}{D_i} + \Sigma K \right) \frac{V^2}{2g} \right]_{40 \text{ mm}}$$

80 mm pipe:

Ref. p. 3-8.

$$R_e = \frac{D_i V}{\nu} = \frac{(0.0711 \text{ m})(1.35 \text{ m/s})}{8.94 \times 10^{-7} \text{ m}^2/\text{s}}$$

$$= 1.1 \times 10^5 - \text{turbulent flow}$$

$$\epsilon = 0.0015 \text{ mm from Table 3-1}$$

$$\epsilon/D_i = \frac{0.0015 \text{ mm}}{71.1 \text{ mm}} = 0.00002$$

Therefore, $f = 0.028$ from the Moody Diagram (Figure 3-1).

From Sketch C-1, for run A-J the sum of the minor loss coefficients from Table 3-3:

Table C-3
Minor Losses for 80-INF-1500: Run A-J

Minor Loss	K
1 gate valve (open)	0.2
1 swing check valve	2.5
4 x 90° elbows	4(0.9)
1 tee-flow through	0.6
1 concentric reducer	0.08
1 exit	1.0
$\Sigma K =$	7.98

$$h_{L80} = \left(\frac{fL}{D_i} + \Sigma K \right) \frac{V^2}{2g}$$

$$= \left[\frac{(0.028)(7.84 - 1.7 \text{ m})}{0.0711 \text{ m}} + 7.98 \right] \frac{(1.35 \text{ m/s})^2}{2 (9.81 \text{ m/s}^2)}$$

$$= 0.97 \text{ m}$$

From Sketch C-1, for run C-J the sum of the minor loss coefficients from Table 3-3:

Table C-4
Minor Losses for 80-INF-1500: Run C-J

Minor Loss	K
1 swing check valve	2.5
3 x 90° elbows	3(0.9)
1 tee-branch flow	1.6
1 concentric reducer	0.08
1 exit	1.0
$\Sigma K =$	8.08

$$h_{L80} = \left(\frac{fL}{D_i} + \Sigma K \right) \frac{V^2}{2g}$$

$$= \left[\frac{(0.028)(7.33 - 1.7 \text{ m})}{0.0711 \text{ m}} + 8.08 \right] \frac{(1.35 \text{ m/s})^2}{2 (9.81 \text{ m/s}^2)}$$

$$= 0.96 \text{ m}$$

Therefore, use run A-J as worst case for the 80 mm pipe section; $h_L = 0.97 \text{ m}$.

40 mm pipe section:

Ref. p. 3-8.

$$R_e = \frac{D_i V}{\nu} = \frac{(0.0319 \text{ m})(6.71 \text{ m/s})}{8.94 \times 10^{-7} \text{ m}^2/\text{s}}$$

$$= 2.4 \times 10^5 - \text{turbulent flow}$$

$\epsilon = 0.0015 \text{ mm}$ from Table 3-1

$$\epsilon/D_i = \frac{0.0015 \text{ mm}}{31.9 \text{ mm}} = 0.00005$$

Therefore, $f = 0.026$ from the Moody Diagram (Figure 3-1).

From Sketch C-1, for run FG the sum of the minor loss coefficients from Table 3-3:

Table C-5 Minor Losses for 80-INF-1500: Run F-G	
Minor Loss	K
1 enlargement	-0.19 (pressure gain)
$\Sigma K =$	-0.19

$$h_{L40} = \left(\frac{fL}{D_i} + \Sigma K \right) \frac{V^2}{2g}$$

$$= \left[\frac{(0.026)(1.7 \text{ m})}{0.0319 \text{ m}} + (-0.19) \right] \frac{(6.71 \text{ m/s})^2}{2 (9.81 \text{ m/s}^2)}$$

$$= 2.74 \text{ m}$$

The total pressure drop through line 80-INF-1500: $h_L = 0.97 \text{ m} + 2.74 \text{ m} = 3.71 \text{ m}$ or 35.4 kPa. This does not include the pressure drop resulting from the control valve, FCV-1570.

Step 4. Size the control valve, FCV-1570, such that the pressure drop through FCV-1570 = 33% of the piping system loss = 0.33 (36.4 kPa) = 12.0 kPa. The flow measurement device is proportional to flow squared so that an equal percentage for characteristic is desired. Assume a ball valve with V-port will be used so let $F_d = 1.0$, and $R_m = 0.9$ (from Table 10-9). From reference materials, $s.g. = 1.0$.

Ref. p. 10-13.

$$C_v = \frac{Q}{N_1} \sqrt{\frac{s.g.}{\Delta P}}$$

$$= \frac{(5.36 \times 10^{-3} \text{ m}^3/\text{s})(3600 \text{ s/hr})}{0.085} \sqrt{\frac{1.0}{12.0 \text{ kPa}}}$$

$$= 65.5$$

$$Re_v = \frac{N_4 F_d Q}{\nu R_m^{1/2} C_v^{1/2}} \left[\frac{R_m^2 C_v^2}{N_2 d^4} + 1 \right]^{1/4} =$$

$$\frac{(76,000)(1.0)[(5.36 \times 10^{-3})(3600)]}{(894)(0.9)^{1/2}(65.5)^{1/2}} \times$$

$$\left[\frac{(0.9)^2(65.5)^2}{(0.00214)(80)^4} + 1 \right]^{1/4} = 2.2 \times 10^5$$

$F_R = 1.0$ from Figure 10-4 (a viscosity correction is not required due to the high Reynolds number).

Ref. p. 10-13.

$$C_{vc} = (C_v)(F_R) = (65.5)(1.0) = 65.5$$

From manufacturer's data (see Table C-6), a 80 mm, 60° V-port ball valve at 80% travel in a 80 mm pipe has a C_v of 67.2 and a R_m of 0.86.

Ref. p. 10-13.

$$\Delta P_{actual} = \frac{s.g.}{\left(\frac{N_1 C_v}{Q}\right)^2}$$

$$= \frac{1.0}{\left(\frac{(0.085)(67.2)}{(5.36 \times 10^{-3})(3600)}\right)^2} = 11.4 \text{ kPa}$$

Step 5. The required pump head is equal to the sum of the elevation change, the piping pressure drop and the valve pressure loss.

$$P_{head} = 23.9 \text{ kPa} + 36.4 \text{ kPa} + 11.4 \text{ kPa}$$

$$= 71.7 \text{ kPa} \times 1.25 \text{ safety factor}$$

$$= 89.6 \text{ kPa}$$

Step 6. The control valve ΔP is checked. The valve inlet pressure, P_i , is equal to the required pump head less the piping losses from the pump to the valve (C-FCV on Sketch 1; approximately 4.9 kPa).

$$P_i = 89.6 \text{ kPa} - 4.9 \text{ kPa} = 84.7 \text{ kPa}$$

Ref. p. 10-17.

$$\Delta P_{allow} = R_m^2 (P_i - r_c P_v)$$

$$= (0.86)^2 [84.7 \text{ kPa} - (0.96)(13.17 \text{ kPa})]$$

$$\Delta P_{allow} = 60.4 \text{ kPa} > \Delta P_v,$$

so the valve is acceptable.

PRESSURE INTEGRITY

The design pressure is equal to the required pump head = 89.6 kPa. No potential pressure transients exist because the valve fails in the last position. An external corrosion allowance of 2 mm is to be designed. Pressure integrity is acceptable if the minimum wall thicknesses for both the 80 mm and 40 mm pipe sections meet ASME 31.3 code. For ASTM A 106, Grade A pipe, ASME B31.3 tables provide $S = 110 \text{ MPa}$, $E = 1.0$, and $\gamma = 0.4$.

Ref. p. 3-15.

$$t_m = t + A = \frac{P D_o}{2 (S E + P \gamma)} + A$$

80 mm pipe:

$$t_m = \frac{(0.0896 \text{ MPa})(90 \text{ mm})}{2[(110 \text{ MPa})(1.0) + (0.0896 \text{ MPa})(0.4)]}$$

$$+ 2 \text{ mm} = 2.04 \text{ mm}$$

The commercial wall thickness tolerance for seamless rolled pipe is +0, -12½%.

$$t_{NOM} = \frac{2.04 \text{ mm}}{1.0 - 0.125} = 2.3 \text{ mm}$$

Nominal 80 mm pipe has a thickness of 5 mm; therefore, the 80 mm pipe section satisfies pressure integrity.

Table C-6
Flow Coefficient - C_v - Characterized Seat Control Valves

Valve Size mm (in)	Line Size mm (in)	Percent of Rated Travel (Degree of Rotation)									
		10 (9)	20 (18)	30 (27)	40 (36)	50 (45)	60 (54)	70 (63)	80 (72)	90 (81)	100 (90)
12.7 (0.5), 6.35 (0.25), 0.79 (0.0313) Wide Slot	15 (½)	0.02	0.03	0.07	0.12	0.16	0.20	0.24	0.28	0.32	0.36
	20 (¾)	0.02	0.03	0.07	0.10	0.14	0.18	0.21	0.25	0.29	0.32
	25 (1)	0.02	0.03	0.06	0.10	0.13	0.16	0.18	0.21	0.27	0.30
12.7 (0.5), 6.35 (0.25), 1.59 (0.0625) Wide Slot	15 (½)	0.02	0.07	0.20	0.33	0.46	0.60	0.73	0.86	0.99	1.10
	20 (¾)	0.02	0.06	0.18	0.29	0.41	0.53	0.65	0.77	0.88	0.98
	25 (1)	0.02	0.06	0.17	0.27	0.38	0.50	0.61	0.71	0.82	0.91
12.7 (0.5), 6.35 (0.25) 30°V	15 (½)	0.02	0.10	0.20	0.34	0.55	0.83	1.11	1.59	2.08	2.50
	20 (¾)	0.02	0.09	0.18	0.30	0.49	0.74	0.99	1.41	1.85	2.22
	25 (1)	0.02	0.08	0.17	0.28	0.46	0.69	0.92	1.32	1.73	2.07
12.7 (0.5), 6.35 (0.25) 60°V	15 (½)	0.02	0.12	0.33	0.90	0.84	1.35	1.95	3.10	4.37	5.92
	20 (¾)	0.02	0.10	0.29	0.44	0.75	1.20	1.74	2.76	3.90	5.27
	25 (1)	0.02	0.10	0.27	0.41	0.70	1.12	1.62	2.57	3.63	4.91
25 (1) 30°V	25 (1)	0.02	0.21	0.56	0.96	1.58	2.39	3.43	4.62	6.15	7.26
	40 (1.5)	0.02	0.16	0.44	0.75	1.23	1.86	2.68	3.60	4.80	5.66
	50 (2)	0.02	0.15	0.40	0.69	1.14	1.72	2.47	3.33	4.43	5.23
25 (1) 60°V	25 (1)	0.02	0.30	0.78	1.24	2.27	3.59	5.28	8.29	11.6	15.5
	40 (1.5)	0.02	0.23	0.61	0.97	1.77	2.80	4.12	6.47	9.05	12.1
	50 (2)	0.02	0.22	0.56	0.89	1.63	2.58	3.80	5.97	8.35	11.2
50 (2) 30°V	50 (2)	0.02	0.55	1.72	3.41	5.65	8.26	12.1	16.6	22.2	26.5
	80 (3)	0.02	0.45	1.41	2.80	4.63	6.77	9.92	13.6	18.2	21.7
	100 (4)	0.02	0.41	1.27	2.52	4.18	6.11	8.95	12.3	16.4	19.6
50 (2) 60°V	50 (2)	0.02	0.70	2.64	4.90	9.32	15.5	22.2	32.1	47.2	61.6
	80 (3)	0.02	0.57	2.16	4.02	7.64	12.7	18.2	26.3	38.7	50.5
	100 (4)	0.02	0.52	1.95	3.63	6.90	11.5	16.4	23.8	34.9	45.6
80 (3) 30°V	80 (3)	0.02	0.75	2.68	6.00	10.2	16.9	24.5	33.9	44.8	54.2
	100 (4)	0.02	0.54	1.93	4.32	7.34	12.2	17.6	24.4	32.3	39.0
	150 (6)	0.02	0.41	1.47	3.30	5.61	9.30	13.5	18.6	24.6	29.8
80 (3) 60°V	80 (3)	0.02	0.95	4.25	10.1	18.6	29.4	46.3	67.2	94.4	124.6
	100 (4)	0.02	0.68	3.06	7.27	13.4	21.2	33.3	48.4	68.0	89.7
	150 (6)	0.02	0.52	2.34	5.56	10.2	16.2	25.5	37.0	51.9	68.5
100 (4) 30°V	100 (4)	0.02	0.80	3.59	8.50	16.1	26.8	40.2	56.6	72.5	89.8
	150 (6)	0.02	0.52	2.33	5.53	10.5	17.4	26.1	36.8	47.1	58.4
	200 (8)	0.02	0.44	1.97	4.68	8.86	14.7	22.1	31.1	39.9	49.4
100 (4) 60°V	100 (4)	0.02	0.90	5.69	15.4	28.8	48.6	73.4	107.0	150.7	200.0
	150 (6)	0.02	0.59	3.70	10.0	18.7	31.6	47.7	69.6	98.0	130.0
	200 (8)	0.02	0.50	3.13	8.47	15.8	26.7	40.4	58.9	82.9	110.0
R_M		0.96	0.95	0.94	0.93	0.92	0.90	0.88	0.86	0.82	0.75

Note: C_v is defined as the flow of liquid in gallons per minute through a valve with a pressure drop of 1 psi across the valve.
Source: Table condensed from Worchester Controls "Series CPT Characterized Seat Control Valve", PB-V-3, Supplement 1.

40 mm pipe:

$$t_m = \frac{(0.0896 \text{ MPa})(50 \text{ mm})}{2[(110 \text{ MPa})(1.0) + (0.0896 \text{ MPa})(0.4)]} + 2 \text{ mm} = 2.02 \text{ mm}$$

The commercial wall thickness tolerance for seamless rolled pipe is +0, -12½%.

$$t_{NOM} = \frac{2.02 \text{ mm}}{1.0 - 0.125} = 2.3 \text{ mm}$$

Nominal 40 mm pipe has a thickness of 5 mm; therefore, the 40 mm pipe section satisfies pressure integrity.

LOADS

Step 1. Pressure - See the pressure integrity calculations for the design pressure.

Step 2. Weight - The 80-INF-1500 dead weight is strictly the piping. 80-INF-1500 will not be insulated because it will be under continuous use. Because the piping section will be continuously full, the weight of the fluid will be determined as part of the dead weight.

$$W = W_p + W_L = A_p \delta_p + \frac{\pi}{4} D_i^2 \delta_L$$

From a lined piping manufacturer, $(A_p)(\delta_p) = 133 \text{ N/m}$ for 80 mm lined piping and 67.1 N/m for 40 mm lined piping.

80 mm pipe:

$$W_{80} = 133 \text{ N/m} + \frac{\pi}{4} 71.1 \text{ mm}^2 (9781 \text{ N/m}^3) x (10^{-6} \text{ m}^2/\text{mm}^2) = 172 \text{ N/m; uniformly distributed}$$

40 mm pipe:

$$W_{40} = 67.1 \text{ N/m} + \frac{\pi}{4} 31.9 \text{ mm}^2 (9781 \text{ N/m}^3) x (10^{-6} \text{ m}^2/\text{mm}^2) = 74.9 \text{ N/m; uniformly distributed}$$

Step 3. Wind - From TI 809-01, the basic wind speed is 40.2 m/s. The plant is located in an area with exposure C (open terrain with scattered obstructions having heights less than 10 m) so a gust factor of 33% is added to the basic wind speed to determine the design wind speed, V_{dw} .

$$V_{dw} = (40.2 \text{ m/s}) (1.33) = 53.5 \text{ m/s}$$

(or 192.6 km/hr, > minimum of 161 km/hr)

80 mm pipe:

Ref. p. 2-7.

$$R_{e80} = C_{W2} V_W D_o = 6.87 (53.5 \text{ m/s}) (90 \text{ mm}) = 3.3 \times 10^4$$

Using the R_e value in the ASCE 7 drag coefficient chart and assuming an infinite circular cylinder (i.e., L:D > 5:1), $C_D = 1.21$.

Ref. p. 2-7.

$$F_{W80} = C_{W1} V_W^2 C_D D_o = (2.543 \times 10^{-6})(53.5 \text{ m/s})^2 (1.21)[90 \text{ mm} + 2(0)] = 0.79 \text{ N/m}$$

40 mm pipe:

Ref. p. 2-7.

$$R_{e40} = C_{W2} V_W D_o$$

$$= 6.87 (53.5 \text{ m/s}) (50 \text{ mm}) = 1.8 \times 10^4$$

Using the R_e value in the ASCE 7 drag coefficient chart and assuming an infinite circular cylinder (i.e., L:D > 5:1), $C_D = 1.21$.

Ref. p. 2-7.

$$F_{W40} = C_{W1} V_W^2 C_D D_o$$

$$= (2.543 \times 10^{-6})(53.5 \text{ m/s})^2 (1.21)[50 \text{ mm} + 2(0)]$$

$$= 0.44 \text{ N/m}$$

The design wind loads are uniformly distributed horizontally (i.e., perpendicular to the weight load).

Step 4. Snow - From TI 809-01, the basic snow load is 239 kPa.

80 mm pipe:

Ref. p. 2-8.

$$W_{s80} = \frac{1}{2} n D_o S_L$$

$$= \frac{1}{2} (10^{-3} \text{ m/mm}) [90 \text{ mm} + 2(0)] (239 \text{ kPa})$$

$$= 10.8 \text{ N/m}$$

40 mm pipe:

Ref. p. 2-8.

$$W_{s40} = \frac{1}{2} n D_o S_L$$

$$= \frac{1}{2} (10^{-3} \text{ m/mm}) [50 \text{ mm} + 2(0)] (239 \text{ kPa})$$

$$= 5.98 \text{ N/m}$$

The design snow loads are uniformly distributed and additive to the weight.

Step 5. Ice - No data is readily available; therefore, assume a maximum buildup of 12.5 mm.

80 mm pipe:

Ref. p. 2-8.

$$W_{I80} = \pi n_3 S_I t_I (D_o + t_I) = \pi (10^{-6} \text{ m}^2/\text{mm}^2) \times$$

$$(8820 \text{ N/m}^3)(12.5 \text{ mm})(90 + 12.5 \text{ mm})$$

$$= 35.5 \text{ N/m}$$

40 mm pipe:

Ref. p. 2-8.

$$W_{I40} = \pi n_3 S_I t_I (D_o + t_I) = \pi (10^{-6} \text{ m}^2/\text{mm}^2) \times$$

$$(8820 \text{ N/m}^3)(12.5 \text{ mm})(50 + 12.5 \text{ mm})$$

$$= 21.6 \text{ N/m}$$

The design ice loads are uniformly distributed and additive to the weight.

Step 6. Seismic - From TM 5-809-10, the facility is located in a seismic zone 0; therefore, the seismic loading is not applicable.

Step 7. Thermal - Thermal loads will be examined under the stress analysis. The coefficient of thermal expansion = $1.11 \times 10^{-5} \text{ mm/mm-}^\circ\text{C}$ over the range 16 to 46 °C.

STRESS ANALYSIS

Step 1. Internal Stresses - 80-INF-1500 meets the pressure integrity requirements; therefore, the limits of stress due to internal pressure are satisfied.

Step 2. External Stresses - For sustained loads, the sum of the longitudinal stresses must be less than the allowable stress at the highest operating temperature:

Ref. p. 3-17.

$$\Sigma S_L \leq S_h;$$

and for occasional loads, the sum of the longitudinal stresses due to both sustained and occasional loads must be less than $1.33 S_h$:

$$\Sigma S'_L \leq 1.33 S_h;$$

To determine the longitudinal stress due to uniformly distributed loads, the support spans and spacing must first be determined. Note that because the liner does not add structural strength, the liner thickness is not included as part of D_i for the purposes of calculating support spans.

80 mm pipe:

Ref. p. 3-25.

$$\begin{aligned} Z_{80} &= \frac{\pi}{32} \frac{D_o^4 - D_i^4}{D_o} \\ &= \frac{\pi}{32} \frac{(90 \text{ mm})^4 - (80 \text{ mm})^4}{(90 \text{ mm})} \\ &= 2.69 \times 10^4 \text{ mm}^3 \end{aligned}$$

It is assumed that snow and ice will not occur concurrently and since the ice loading is greater than the snow loading, the sustained loads are equal to the weight of the piping system and the ice.

$$\begin{aligned} W'_{80} &= 172 \text{ N/m} + 35.5 \text{ N/m} \\ &= 208 \text{ N/m} (10^{-3} \text{ m/mm}) = 0.208 \text{ N/mm} \end{aligned}$$

Ref. p. 3-25.

$$\begin{aligned} l_{80} &= n \left(m C' \frac{Z S}{W} \right)^{0.5} = (10^{-3} \text{ m/mm}) \times \\ &\left[(76.8) \left(\frac{5}{48} \right) \frac{(2.69 \times 10^4 \text{ mm}^3) (10.3 \text{ MPa})}{(0.208 \text{ N/mm})} \right]^{0.5} \\ &= 3.26 \text{ m} \end{aligned}$$

The span length is less than the MSS SP-69 guidance for schedule 40 carbon steel filled with water (3.7 m), so length is acceptable.

40 mm pipe:

Ref. p. 3-25.

$$\begin{aligned} Z_{40} &= \frac{\pi}{32} \frac{D_o^4 - D_i^4}{D_o} \\ &= \frac{\pi}{32} \frac{(50 \text{ mm})^4 - (40 \text{ mm})^4}{(50 \text{ mm})} \\ &= 7.25 \times 10^3 \text{ mm}^3 \end{aligned}$$

It is assumed that snow and ice will not occur concurrently and since the ice loading is greater than the snow loading, the sustained loads are equal to the weight of the piping system and the ice.

$$\begin{aligned} W'_{40} &= 74.9 \text{ N/m} + 21.6 \text{ N/m} \\ &= 96.5 \text{ N/m} (10^{-3} \text{ m/mm}) = 9.65 \times 10^{-2} \text{ N/mm} \end{aligned}$$

Ref. p. 3-25.

$$\begin{aligned} l_{40} &= n \left(m C' \frac{Z S}{W} \right)^{0.5} = (10^{-3} \text{ m/mm}) \times \\ &\left[(76.8) \left(\frac{5}{48} \right) \frac{(7.25 \times 10^3 \text{ mm}^3) (10.3 \text{ MPa})}{(9.65 \times 10^{-2} \text{ N/mm})} \right]^{0.5} \\ &= 2.49 \text{ m} \end{aligned}$$

The span length is less than the MSS SP-69 guidance for schedule 40 carbon steel filled with water (2.7 m), so length is acceptable.

Therefore, the check for longitudinal stresses from sustained loads is as follows.

80 mm pipe:

Ref. p. 3-17.

$$\begin{aligned}\Sigma S_{L80} &= \frac{P D_o}{4 t} + 0.1 \frac{W L^2}{n Z} \\ &= \frac{(0.0896 \text{ MPa})(90 \text{ mm})}{4 (5 \text{ mm})} + \\ &0.1 \frac{(172 \text{ N/m})(3.26 \text{ m})^2}{(10^{-3} \text{ m/mm})(2.69 \times 10^4 \text{ mm}^3)} = 6.6 \text{ MPa}\end{aligned}$$

40 mm pipe:

Ref. p. 3-17.

$$\begin{aligned}\Sigma S_{L40} &= \frac{P D_o}{4 t} + 0.1 \frac{W L^2}{n Z} \\ &= \frac{(0.0896 \text{ MPa})(50 \text{ mm})}{4 (5 \text{ mm})} + \\ &0.1 \frac{(74.9 \text{ N/m})(1.7 \text{ m})^2}{(10^{-3} \text{ m/mm})(7.25 \times 10^3 \text{ mm}^3)} = 2.9 \text{ MPa}\end{aligned}$$

From ASME B31.3, Table A-1, $S_h = 110 \text{ MPa}$. For both pipes, $\Sigma S_L \leq S_h$; therefore, the pipes are acceptable for sustained loads.

Assuming that snow and ice will not occur simultaneously and ignoring the wind load (small and horizontal to the snow/ice load), the ice load will be the worst case and the check for occasional loads is as follows.

80 mm pipe:

Ref. p. 3-17.

$$\begin{aligned}\Sigma S'_{L80} &= \Sigma S_{L80} + 0.1 \frac{W L^2}{n Z} = 6.6 \text{ MPa} + \\ &0.1 \frac{(35.5 \text{ N/m})(3.26 \text{ m})^2}{(10^{-3} \text{ m/mm})(2.69 \times 10^4 \text{ mm}^3)} = 8.0 \text{ MPa}\end{aligned}$$

40 mm pipe:

Ref. p. 3-17.

$$\begin{aligned}\Sigma S'_{L40} &= \Sigma S_{L40} + 0.1 \frac{W L^2}{n Z} = 2.9 \text{ MPa} + \\ &0.1 \frac{(21.6 \text{ N/m})(1.7 \text{ m})^2}{(10^{-3} \text{ m/mm})(7.25 \times 10^3 \text{ mm}^3)} = 3.8 \text{ MPa} \\ &1.33 S_h = 1.33 (110 \text{ MPa}) = 146 \text{ MPa}\end{aligned}$$

For both pipes, $\Sigma S'_L \leq 1.33 S_h$; therefore, the pipes are acceptable for the anticipated occasional loads.

Step 3. To ensure that piping systems have sufficient flexibility to prevent these failures, ASME B31.3 requires that the displacement stress range does not exceed the allowable displacement stress range. Due to the length of the 40 mm pipe section, flexibility is not a factor. Therefore, only the flexibility of the 80 mm pipe section will be checked. From ASME B31.3, Table 302.3.5 and with the assumption that the total process cycles over the process life will be less than 7000, $f = 1.0$. From ASME B31.1, Table A-1, $S_c = S_h = 110 \text{ MPa}$.

Ref. p. 3-18.

$$S_E \leq S_A; \text{ and } S_A = f [1.25 (S_c + S_h) - S_L]$$

$$\begin{aligned}S_A &= 1.0[(1.25)(110 \text{ MPa} + 110 \text{ MPa}) - 7 \text{ MPa}] \\ &= 268 \text{ MPa; therefore, } S_E \leq 268 \text{ MPa}\end{aligned}$$

The center of gravity is located to review the stability of the system with respect to the fittings and equipment loads.

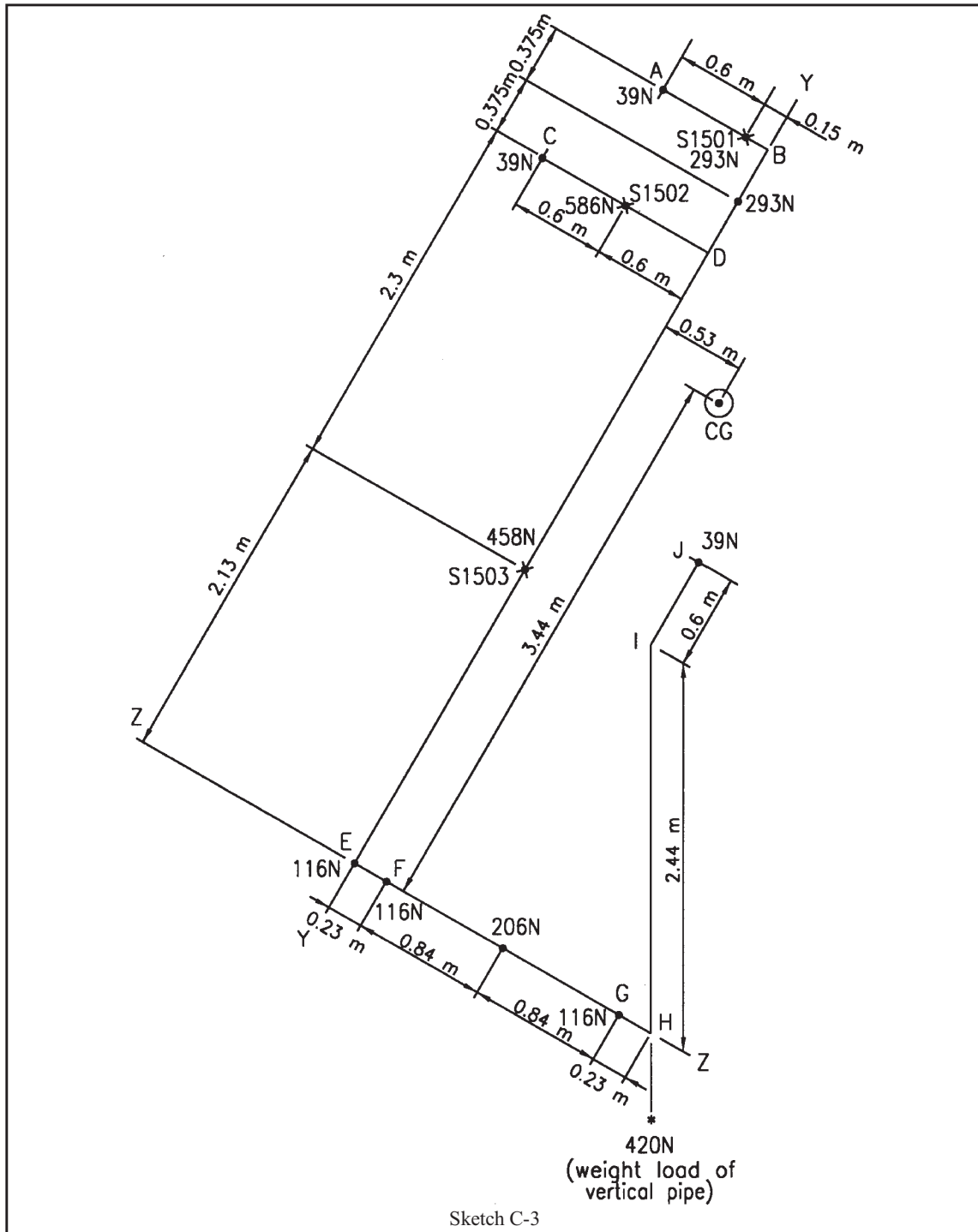

Referencing Sketch C-3:

x = support location (S1501 supports a check valve, S1502 supports a check valve and a gate valve, and S1503 supports the control valve).

● = component load
○ = center of gravity

E - 116 N
F - 116 N
FG - 206 N
G - 116 N
H - 420 N
J - 39 N.

The loads and their locations are as follows:

A - 39 N
S1501 - 293 N
BD - 293 N
C - 39 N
S1502 - 586 N
S1503 - 458 N

Table C-7 contains the results of the moment calculations. The center of gravity of the piping section is behind S1503; therefore, 2 more supports are needed for stability. Locate S1504 and S1505 at points F and G respectively. S1505 supports the vertical run and keeps the load off of the equipment flange.

Table C-7
Line 80-INF-1500 Moments

moment about axis y-y			moment about axis z-z		
N	m	N-m	N	m	N-m
39	-0.75	-29.3	39	0.6	23.4
293	-0.15	-44.0	103	0.3	30.9
129	-0.375	-48.4	39	5.18	202
39	-1.2	-46.8	293	5.18	1520
586	-0.6	-352	129	5.18	668
206	-0.6	-124	293	4.8	1410
39	2.14	83.5	39	4.43	173
103	2.14	220	586	4.43	2600
420	2.14	899	206	4.43	913
116	1.91	222	891	2.59	2710
206	1.07	220	458	2.13	976
116	0.23	26.7			
367	1.07	393			
2660		1420	3080		10600

$$\frac{1,420 \text{ N-m}}{2,660 \text{ N}} = 0.53 \text{ m from } y-y;$$

$$\frac{10,600 \text{ N-m}}{3,080 \text{ N}} = 3.44 \text{ m from } z-z.$$

The thermal expansion deflections are determined based on: 1) the manufacturer of the air stripper, P1600, has indicated that a 1.6 mm upward movement of the flange mating at point J will occur when operating conditions are established; 2) the flanges at points A and C mate with pumps and are not subject to movements; 3) support S1505, located at point G supports piping section H-I-J and will prevent vertical deflection at point H; and 4) given that the piping system will be installed at 21 °C, the thermal expansion of the piping will be:

$$\Delta L = (1.11 \times 10^{-5} \text{ mm/mm-}^\circ\text{C}) \times (1,000 \text{ mm/m})(46^\circ\text{C} - 21^\circ\text{C}) = 0.278 \text{ mm/m}.$$

Sketch C-4 depicts the approximate deflections that will occur. These deflections are:

- AB will deflect out at point B,(0.75 m) (0.278 mm/m) = 0.21 mm
- CD will deflect out at point D,(1.2 m) (0.278 mm/m) = 0.33 mm
- BE will deflect out at point E,(5.18 m) (0.278 mm/m) = 1.4 mm
- EH will deflect out at each end,[(0.5)(2.14 m)] (0.278 mm/m) = 0.30 mm
- HI will deflect up at point I,(2.44 m) (0.278 mm/m) = 0.68 mm
- IJ will deflect out at point I,(0.6 m) (0.278 mm/m) = 0.17 mm

From beam calculations,

1) for sections BE and EH:

$$M = \frac{3 E I y}{a (l + a)} (n)$$

where:

- a_{BE} = the length from S1503 to point E
- a_{EH} = the length from S1504 to point E

$$n = 10^{-9} \text{ m}^3/\text{mm}^3$$

$$E = 2.03 \times 10^5 \text{ MPa (reference ASME B31.3, Table C-6)}$$

$$I = \frac{\pi}{64} [(D_o)^4 - (D_i)^4]$$

$$= \frac{\pi}{64} [(90 \text{ mm})^4 - (80 \text{ mm})^4]$$

$$= 1.21 \times 10^6 \text{ mm}^4$$

2) for sections HI and IJ:

$$M = \frac{3 E I y}{L^2}$$

where:

- L_{HI} = length of HI
- L_{IJ} = length of IJ

The displacement stress is now calculated from the deflections.

Ref. p. 3-18.

$$S_E = (S_b^2 + 4S_t^2)^{0.5}$$

Ref. p. 3-18.

$$S_b = \frac{[(i_i M_i)^2 + (i_o M_o)^2]^{0.5}}{Z n}; \text{ and}$$

$$S_t = \frac{M_t}{2 Z n}$$

where:

- M_o = 0
- i_i = i_o = 1.0
- Z = 2.69 x 10⁴ mm³ (see page C-17 for calculation)
- n = 10⁻³ m/mm

Table C-8 summarizes the results of the calculations for each piping segment.

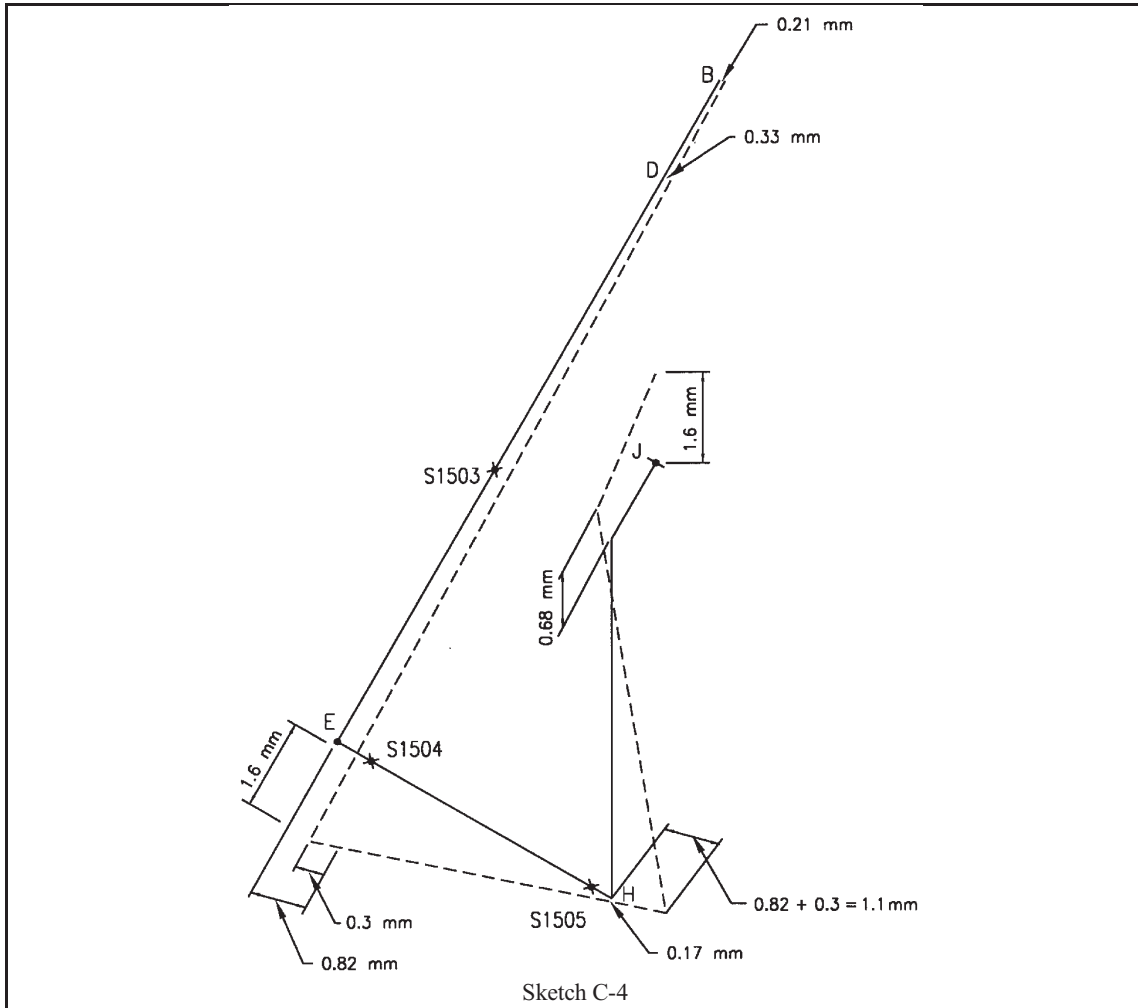

Table C-8
Line 80-INF-1500 Displacement Stresses

Segment	M_i (N-m)	S_b (MPa)	M_i (N-m)	S_i (MPa)	S_E (MPa)
BE	20.0	0.74	0	0	0.74
EH	2395	89.0	42.0	0.78	89.0
HI	21.0	0.78	0	0	0.78
IJ	1883	70.0	272	5.1	70.7

In all of the piping segments, $S_E < \bar{S}$ (268 MPa); therefore, line 80-INF-1500 satisfies required flexibility constraints.

SUPPORTS

The support spacing and spans were calculated as part of the stress analyses. The types of supports are selected based upon process temperature (see Table 3-8) and application (see Figure 3-2 and MSS SP-69).

Table C-9
Line 80-INF-1500 Supports

Support	Type (MSS SP-58)
S1501	36
S1502	36
S1503	36
S1504	36
S1505	37

FLANGE CONNECTIONS

From Table 9-2, the flange connections for the thermoplastic lined 80-INF-1500 shall have the following bolting requirements:

- 80 mm flanges: 4 x 16 mm bolts per flange
ASTM A 193 bolts and nuts, lightly oiled
169 N-m bolt torque for PVDF lined piping.
- 40 mm flanges: 4 x 14 mm bolts per flange
ASTM A 193 bolts and nuts, lightly oiled
81 N-m bolt torque for PVDF lined piping.

- b. Line XXX-IAS-1600**
Air Stripper P1600 Effluent to Duplex Pumps P1605/1610

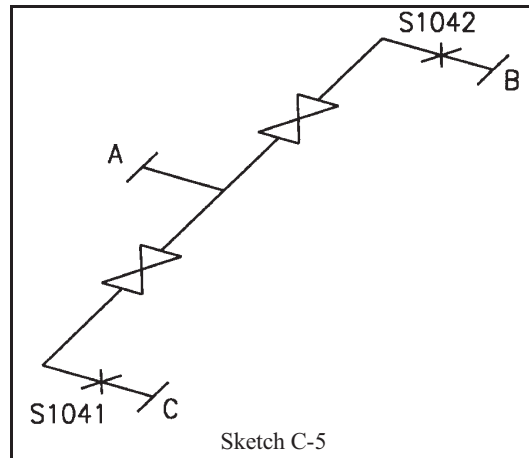

Flow is either through A-B or A-C, but not both simultaneously

Maximum Flowrate, $Q = 5.36 \times 10^{-3} \text{ m}^3/\text{s}$

MATERIAL OF CONSTRUCTION

Line XXX-IAS-1600 handles essentially the same fluid as 80-INF-1500 except that most of the volatile organic solvents have been stripped out. Therefore, for constructability purposes, make the materials of construction identical to 80-INF-1500:

The piping shall be ASTM A 106, Grade A, carbon steel lined with PVDF that has a minimum thickness of 4.45 mm. Because the line is on the influent side of the pumps, the piping shall be full vacuum rated pursuant to ASTM F 423. Joints and fittings shall be chamfered threaded flanges.

The sizing is identical to 80-INF-1500 because the maximum flowrate is identical. Therefore, the line designation is amended to 80-IAS-1600.

The pressure integrity, loads, stress analysis and flexibility are similar to 80-INF-1500; therefore, line 80-IAS-1600 is acceptable.

SUPPORTS

Locate supports as shown (spans are less than the maximum spans calculated for 80-INF-1500); support type as follows.

Table C-10 Line 80-IAS-1600 Supports	
Support	Type (MSS SP-58)
S1041	36
S1042	36

FLANGE CONNECTIONS

From Table 9-2, the flange connections for the thermoplastic lined 80-IAS-1600 shall have the following bolting requirements:

80 mm flanges: 4 x 16 mm bolts per flange
 ASTM A 193 bolts and nuts, lightly oiled
 169 N-m bolt torque for PVDF lined piping.

- c. **Line XXX-IAS-1620**
 Duplex Pumps P1605/1610 Discharge to Reactor P1620

Referencing Sketch C-6:

Flow is either through A-D or C-D, but not both simultaneously

Maximum Flowrate, $Q = 5.36 \times 10^{-3} \text{ m}^3/\text{s}$

Elevation Change = -0.61 m (= -5.98 kPa)

Total run
 = 8.55 m for A-H
 = 7.19 m for C-H

Back-pressure from liquid level in Reactor P1620 = 3.65 m (35.8 kPa).

Fittings (identical for either A-H or C-H)

- 1 swing check valve
- 2 gate valves (isolation)

MATERIAL OF CONSTRUCTION

Line XXX-IAS-1620 handles essentially the same fluid as 80-IAS-1600. Therefore, for constructability purposes, make the materials of construction identical to 80-INF-1500 and 80-IAS-1600:

The piping shall be ASTM A 106, Grade A, carbon steel lined with PVDF that has a minimum thickness of 4.45 mm. Because the line is on the influent side of the pumps, the piping shall be full vacuum rated pursuant to ASTM F 423. Joints and fittings shall be chamfered threaded flanges.

SIZING/PRESSURE DROP

The sizing is identical to 80-INF-1500 and 80-IAS-1600 because the maximum flowrate is identical: lined $D_i = 71.1 \text{ mm}$, $V = 1.35 \text{ m/s}$, and $D_o = 90 \text{ mm}$ (5 mm wall thickness). Therefore, the line designation is amended to 80-IAS-1620.

At 23.9°C, $\nu = 8.94 \times 10^{-7} \text{ m}^2/\text{s}$ and the Darcy-Weisbach equation is used to calculate the pressure drop through the piping. The worst case pressure drop will be run A-H due to the additional pipe length.

Ref. p. 3-8.

$$h_L = \left[\left(\frac{fL}{D_i} + \Sigma K \right) \frac{V^2}{2g} \right]$$

Ref. p. 3-8.

$$R_e = \frac{D_i V}{\nu} = \frac{(0.0711 \text{ m})(1.35 \text{ m/s})}{8.94 \times 10^{-7} \text{ m}^2/\text{s}}$$

$$= 1.1 \times 10^5 - \textit{turbulent flow}$$

$$\epsilon = 0.0015 \text{ mm from Table 3-1}$$

$$\epsilon/D_i = \frac{0.0015 \text{ mm}}{71.1 \text{ mm}} = 0.00002$$

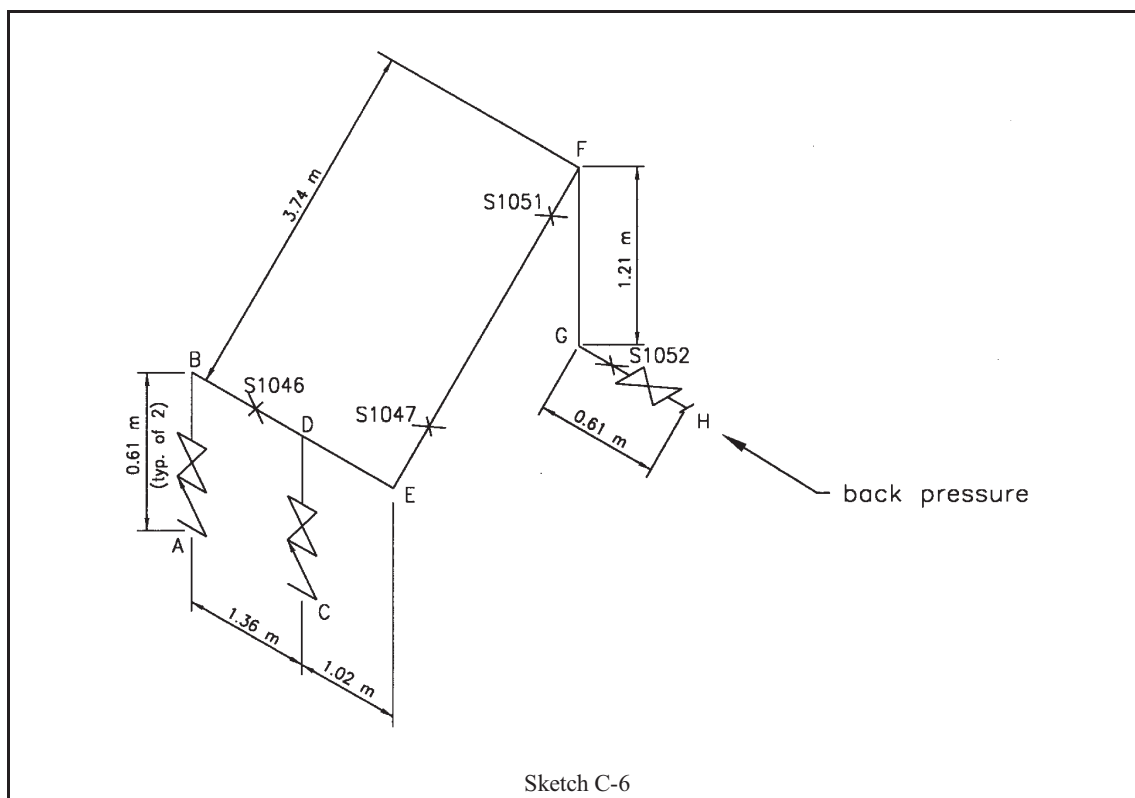

Therefore, $f = 0.028$ from the Moody Diagram (Figure 3-1). From Sketch C-6, for run A-H the sum of the minor loss coefficients from Table 3-3:

Table C-11 Minor Losses for 80-IAS-1620: Run A-H	
Minor Loss	K
2 gate valves (open)	2(0.2)
1 swing check valve	2.5
4 x 90° elbows	4(0.9)
1 tee-flow through	0.6
1 exit	1.0
$\Sigma K =$	8.1

$$\begin{aligned}
 h_L &= \left(\frac{fL}{D_i} + \Sigma K \right) \frac{V^2}{2g} \\
 &= \left[\frac{(0.028)(8.55 \text{ m})}{0.0711 \text{ m}} + 8.1 \right] \frac{(1.35 \text{ m/s})^2}{2 (9.81 \text{ m/s}^2)} \\
 &= 1.1 \text{ m (10.8 kPa)}
 \end{aligned}$$

The required pump head is equal to the sum of the elevation change, the piping pressure drop and the back pressure from the reactor P1620.

$$\begin{aligned}
 P_{head} &= -5.98 \text{ kPa} + 10.8 \text{ kPa} + 35.8 \text{ kPa} \\
 &= 40.6 \text{ kPa} \times 1.25 \text{ safety factor} = 50.8 \text{ kPa}
 \end{aligned}$$

PRESSURE INTEGRITY

The design pressure is equal to the required pump head = 50.8 kPa. No potential pressure transients exist. The design external corrosion allowance is 2 mm. Pressure integrity is acceptable if the minimum wall thickness meets ASME 31.3 code. According to ASME B31.3, for ASTM A 106, Grade A pipe, S = 110 MPa, E = 1.0, and y = 0.4.

Ref. p. 3-15.

$$t_m = t + A = \frac{P D_o}{2 (S E + P y)} + A$$

$$t_m = \frac{(0.0508 \text{ MPa})(90 \text{ mm})}{2[(110 \text{ MPa})(1.0) + (0.0508 \text{ MPa})(0.4)]} + 2 \text{ mm} = 2.02 \text{ mm}$$

The commercial wall thickness tolerance for seamless rolled pipe is +0, -12½%.

$$t_{NOM} = \frac{2.02 \text{ mm}}{1.0 - 0.125} = 2.3 \text{ mm}$$

Nominal 80 mm pipe has a thickness of 5 mm; therefore, the 80 mm piping satisfies pressure integrity.

LOADS

Step 1. Pressure - See the pressure integrity calculations for the design pressure.

Step 2. Weight - Load per unit length will be identical to 80-INF-1500; W = 172 N/m (including liquid content).

Step 3. Wind - Load per unit length will be identical to 80-INF-1500; F_w = 0.79 N/m (horizontal).

Step 4. Snow - Load per unit length will be identical to 80-INF-1500; W_s = 10.8 N/m.

Step 5. Ice - Load per unit length will be identical to 80-INF-1500; W_i = 35.5 N/m.

Step 6. Seismic - From TM 5-809-10, the facility is located in a seismic zone 0; therefore, the seismic loading is not applicable.

Step 7. Thermal - Thermal loads will be examined under the stress analysis. The coefficient of thermal expansion = 1.11 x 10⁻⁵ mm/mm-°C over the range 16 to 46 °C.

STRESS ANALYSIS

Step 1. Internal Stresses - Line 80-IAS-1620 meets the pressure integrity requirements; therefore, the limits of stress due to internal pressure are satisfied.

Step 2. External Stresses - For sustained loads, the sum of the longitudinal stresses must be less than the allowable stress at the highest operating temperature:

Ref. p. 3-17.

$$\Sigma S_L \leq S_h;$$

and for occasional loads, the sum of the longitudinal stresses due to both sustained and occasional loads must be less than 1.33 S_h:

$$\Sigma S'_L \leq 1.33 S_h;$$

To determine the longitudinal stress due to uniformly distributed loads, the support spans and spacing must first be determined: maximum support span length, L, = 3.26 m (see 80-INF-1500 stress analysis). Therefore, the check for longitudinal stresses from sustained loads is as follows.

Ref. p. 3-25.

$$Z_{80} = \frac{\pi}{32} \frac{D_o^4 - D_i^4}{D_o}$$

$$= \frac{\pi}{32} \frac{(90 \text{ mm})^4 - (80 \text{ mm})^4}{(90 \text{ mm})}$$

$$= 2.69 \times 10^4 \text{ mm}^3$$

Ref. p. 3-17.

$$\Sigma S_L = \frac{P D_o}{4 t} + 0.1 \frac{W L^2}{n Z} = \frac{(0.0508 \text{ MPa})(90 \text{ mm})}{4 (5 \text{ mm})} + 0.1 \frac{(172 \text{ N/m})(3.26 \text{ m})^2}{(10^{-3} \text{ m/mm})(2.69 \times 10^4 \text{ mm}^3)} = 7.02 \text{ MPa}$$

From ASME B31.3, Table A-1, $S_h = 110 \text{ MPa}$. For 80-IAS-1620, $\Sigma S_L \leq S_h$; therefore, the pipe is acceptable for sustained loads.

Assuming that snow and ice will not occur simultaneously and ignoring the wind load (small and horizontal to the snow/ice load), the ice load will be the worst case and the check for occasional loads is as follows.

Ref. p. 3-17.

$$\Sigma S'_L = \Sigma S_L + 0.1 \frac{W L^2}{n Z} = 7.02 \text{ MPa} + 0.1 \frac{(35.5 \text{ N/m})(3.26 \text{ m})^2}{(10^{-3} \text{ m/mm})(2.69 \times 10^4 \text{ mm}^3)} = 8.42 \text{ MPa}$$

For 80-IAS-1620, $\Sigma S'_L \leq 1.33 S_h$; therefore, the pipe is acceptable for the anticipated occasional loads.

Step 3. To ensure that piping systems have sufficient flexibility to prevent failures resulting from displacement strains, ASME B31.3 requires that the displacement stress range does not exceed the allowable displacement stress range. From ASME B31.3, Table 302.3.5 and with the assumption that the total process cycles over the process life will be less than 7000, $f = 1.0$. From ASME B31.1, Table A-1, $S_c = S_h = 110 \text{ MPa}$.

Ref. p. 3-18.

$$S_E \leq S_A; \text{ and } S_A = f [1.25 (S_c + S_h) - S_L]$$

$$S_A = 1.0 [(1.25)(110 \text{ MPa} + 110 \text{ MPa}) - 7 \text{ MPa}]$$

$$= 268 \text{ MPa}; \text{ therefore, } S_E \leq 268 \text{ MPa}$$

Referencing Sketch C-7:

- x = support location
- = component load

The loads and their locations are as follows:

- B - 807 N
- D - 807 N
- E - 116 N
- F - 116 N
- G - 116 N
- S1052 - 293 N
- H - 39 N.

Based upon the symmetry of the piping segment, the system is stable with the supports located where shown. Support S1046 supports the two vertical runs AB and CD, and the check valves and gate valve at the pump outlets, and S1052 supports the vertical run FG and keeps that load off of the equipment flange. Supports S1047 and S1051 are needed for stability and to keep the maximum span length within the constraint.

The thermal expansion deflections are determined based on: 1) the assumption that no substantial movement of the flange mating at point H will occur when operating conditions are established; 2) the flanges at points A and C mate with pumps and are not subject to movements; 3) support S1052, will prevent vertical deflection at point G; and 4) given that the piping system will be installed at 21°C, the thermal expansion of the piping will be:

$$\Delta L = (1.11 \times 10^{-5} \text{ mm/mm}^\circ\text{C}) \times (1000 \text{ mm/m})(16^\circ\text{C} - 21^\circ\text{C}) = 0.278 \text{ mm/m}$$

Sketch C-8 depicts the approximate deflections that will occur. These deflections are:

- AB will deflect up at point B, (0.61 m) (0.278 mm/m) = 0.17 mm
- CD will deflect up at point D, (0.61 m) (0.278 mm/m) = 0.17 mm
- BE will deflect out at each end, [(0.5)(2.38 m) (0.278 mm/m) = 0.33 mm
- EF will deflect out at each end, [(0.5)(3.74 m)] (0.278 mm/m) = 0.52 mm
- FG will deflect up at point F, (1.21 m) (0.278 mm/m) = 0.34 mm
- GH will deflect out at point G, (0.61 m) (0.278 mm/m) = 0.17 mm

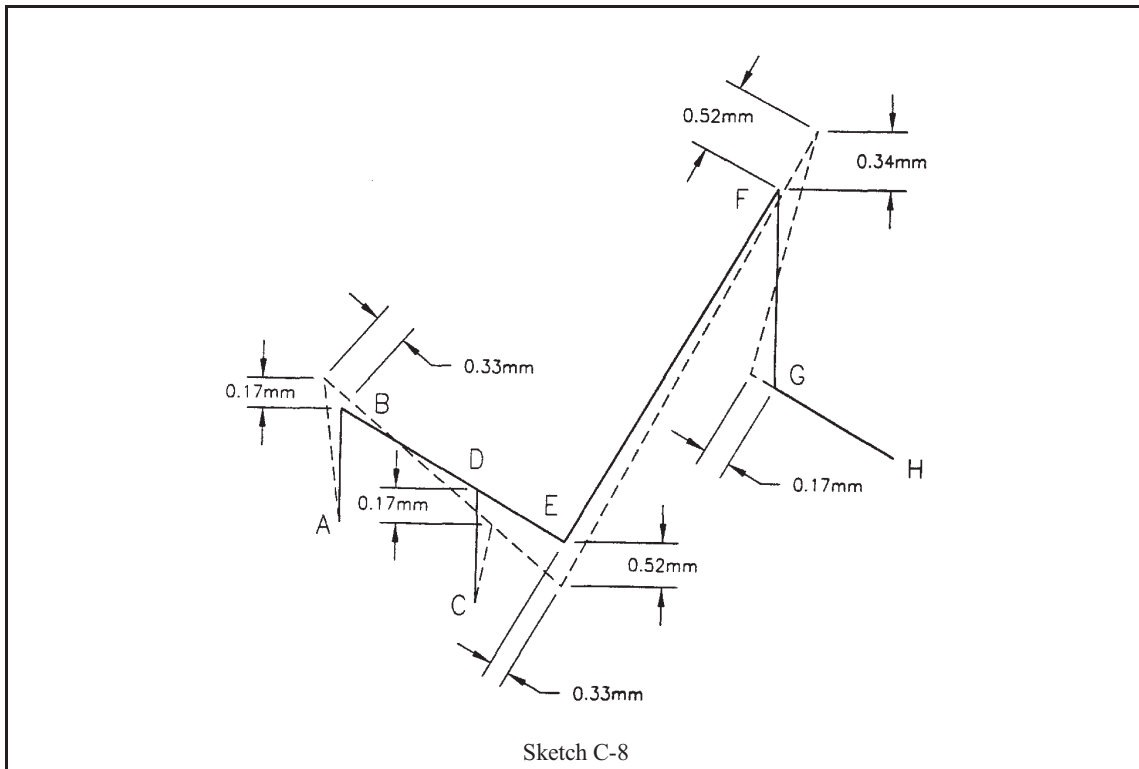
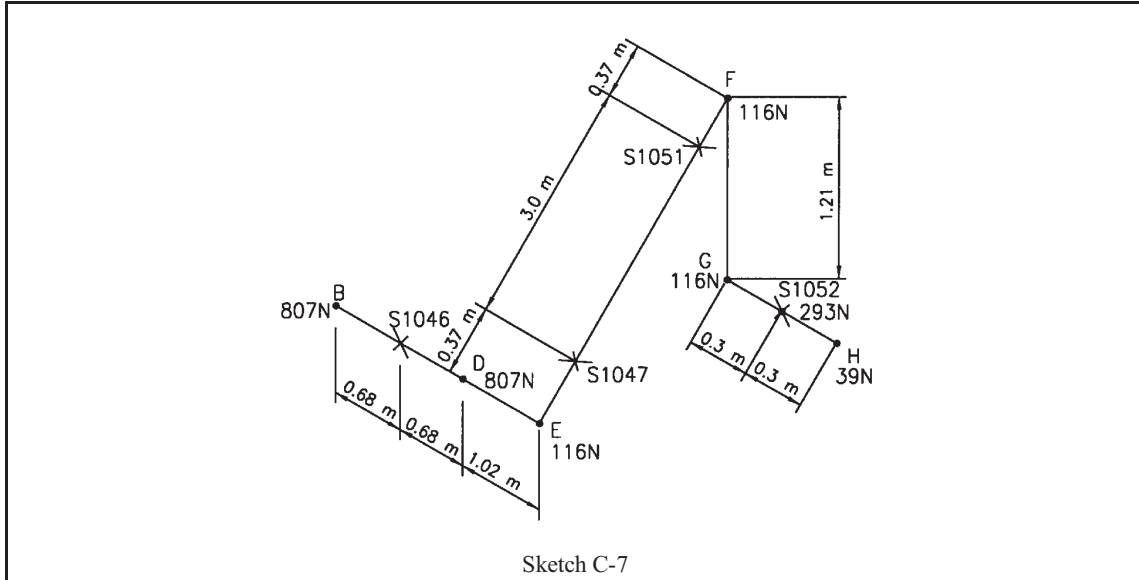

From beam calculations,

1) for sections BE (M_o caused) and EF (M_i and M_o caused):

$$M = \frac{3 E I y}{a (l + a)} (n)$$

where:

$$a_{BE} = 0.37 \text{ m}$$

$$a_{EH} = 1.7 \text{ m}$$

$$n = 10^{-9} \text{ m}^3/\text{mm}^3$$

$$E = 2.03 \times 10^5 \text{ MPa (reference ASME B31.3, Table C-6)}$$

$$I = 1.21 \times 10^6 \text{ mm}^4 \text{ (see 80-INF-1500 calculations)}$$

2) for sections AB, CD and FG:

$$M = \frac{3 E I y}{L^2}$$

where:

$$L_{AB} = \text{length of AB}$$

L_{CD} = length of CD

L_{FG} = length of FG

The displacement stress is now calculated from the deflections.

Ref. p. 3-18:

$$S_E = (S_b^2 + 4S_t^2)^{0.5}$$

$$S_b = \frac{[(i_i M_i)^2 + (i_o M_o)^2]^{0.5}}{Z n} \text{ and } S_t = \frac{M_t}{2 Z n}$$

where:

$$i_i = i_o = 1.0$$

$$Z = 2.69 \times 10^4 \text{ mm}^3 \text{ (see page C-16 for calculation)}$$

$$n = 10^{-3} \text{ m/mm}$$

Table C-12 summarizes the results of the calculations for each piping segment.

In all of the piping segments, $SE < SA$ (268 MPa); therefore, line 80-IAS-1620 satisfies required flexibility constraints.

Table C-12
Line 80-IAS-1620 Displacement Stresses

Segment	M_i (N-m)	M_o (N-m)	S_b (MPa)	M_t (N-m)	S_t (MPa)	S_E (MPa)
AB	654	0	24.3	135	2.51	24.8
CD	277	0	10.3	736	13.7	29.3
BE	67.6	31	2.76	35.8	0.67	3.07
EF	176	181	9.39	0	0	9.39
FG	262	85.6	10.2	0	0	10.2
GH	0	0	0	523	9.72	19.4

SUPPORTS

The support spacing and spans were calculated as part of the stress analyses. The types of supports are selected based upon process temperature (see Table 3-8) and application (see Figure 3-2 and MSS SP-69).

Table C-13
Line 80-IAS-1620 Supports

Support	Type (MSS SP-58)
S1046	38
S1047	38
S1051	38
S1052	37

FLANGE CONNECTIONS

From Table 9-2, the flange connections for the thermoplastic lined 80-IAS-1620 shall have the following bolting requirements:

80 mm flanges: 4 x 16 mm bolts per flange
ASTM A 193 bolts and nuts, lightly oiled
169 N-m bolt torque for PVDF lined piping.

- d. Line 100-PRI-1630**
Process Flow from Reactor P1620 to Floc Tank P1630

The line is gravity flow. Design in accordance with TI 814-10 Wastewater Collection; Gravity Sewers and Appurtenances.

- e. Line 100-EFF-1640**
Clarifier P1640 Effluent to Clearwell P1510

The line is gravity flow. Design in accordance with TI 814-10 Wastewater Collection; Gravity Sewers and Appurtenances.

- f. Line 80-SLG-1650**
Sludge Discharge from Clarifier P1640 to Sludge Pumps

The line is supplied by the process system manufacturer. Provide performance requirements for the piping in the equipment specifications.

- g. Line 25-SLG-1651**
Sludge Recycle from Sludge Pumps to Reactor P1620

The line is supplied by the process system manufacturer. Provide performance requirements for the piping in the equipment specifications.

- h. Line XXX-SLG-1660**
Waste Sludge Discharge from Sludge Pumps to Sludge Pit P1450

Referencing Sketch C-9:

Maximum Flowrate, $Q = 2.75 \times 10^{-3} \text{ m}^3/\text{s}$

Total run = 22.0 m
= 20.3 m below grade

Buried depth = 0.9 m, t.o.p.

Fittings below grade:
3 x 90° elbows
2 x 45° bends
1 x swing check valve

Sludge Pump Head = 250 kPa.

MATERIAL OF CONSTRUCTION

To match other materials at the facility, the piping shall be zinc coated ASTM A 53, Type E, Grade A, carbon steel. Joints shall be butt welded with chill rings. Below grade fittings shall be forged ASTM A 105M steel of the same thickness of the piping and shall conform to ASME B 16.9, butt weld type. The exception to this shall be the connection to the swing check valve; this end connection shall be a welding neck flange and located in a valve box.

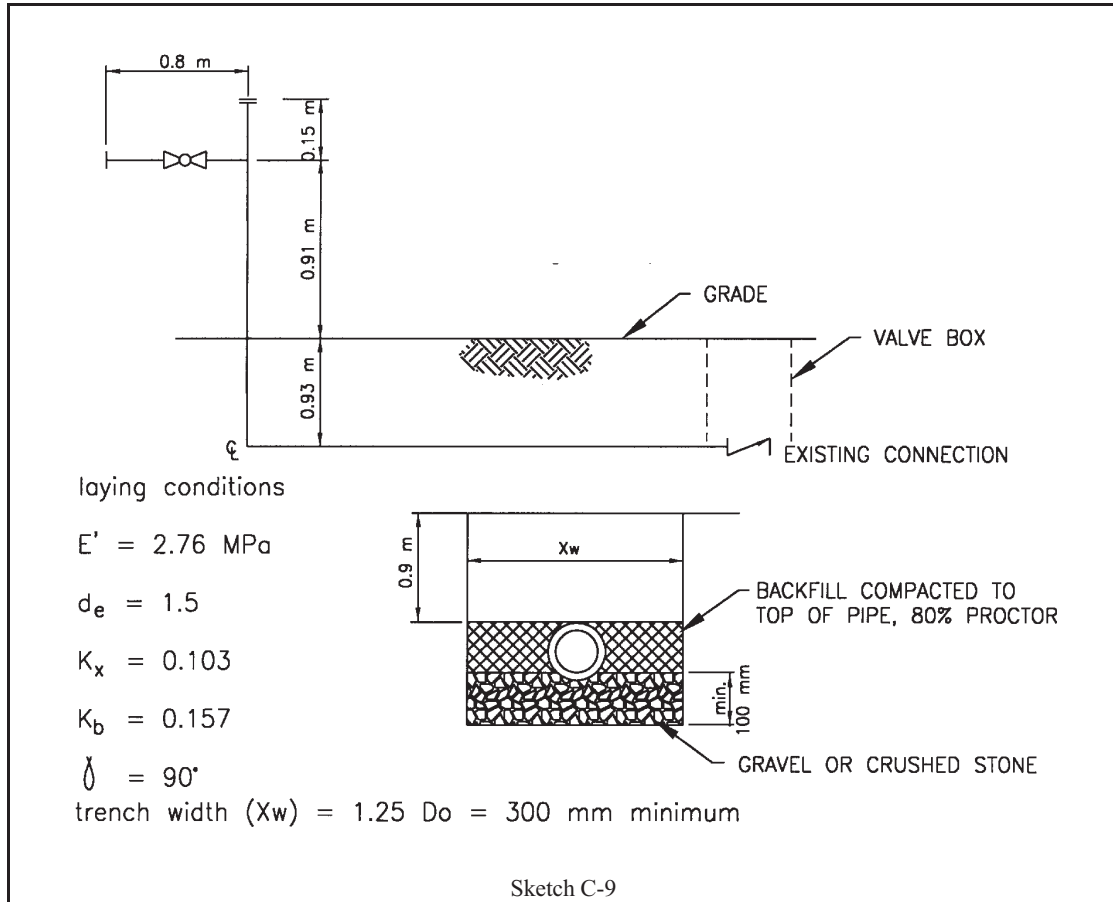

The flange connections to the existing sludge line should be field inspected to ensure a compatible connection. The above ground connection to the waste sludge pump, isolation ball valve and clean-out shall also be flanged. All flanges shall be constructed of ASTM A 105M material.

$$D_i = \left[\frac{4}{\pi} \frac{(2.75 \times 10^{-3}) \text{ m}^3/\text{s}}{2.1 \text{ m/s}} \right]^{0.5} \left(1000 \frac{\text{mm}}{\text{m}} \right)$$

$$= 40.8 \text{ mm}$$

PIPE SIZING/PRESSURE DROP

Step 1. Select pipe size by dividing the volumetric flowrate by the desired velocity (normal service, $V = 2.1 \text{ m/s}$).

$$A = \pi \frac{D_i^2}{4} = \frac{Q}{V}$$

Step 2. From Table 1-1, the size choices are 40 mm or 50 mm. Select 40 mm as the actual pipe size and calculate actual velocity in the pipe.

$$V = \frac{Q}{A} = \frac{Q}{\frac{\pi}{4} D_i^2} = \frac{2.75 \times 10^{-3} \text{ m}^3/\text{s}}{\frac{\pi}{4} (0.040 \text{ m})^2} = 2.19 \text{ m/s}$$

The actual velocity, 2.19 m/s, is within the normal acceptable range, 2.1 ± 0.9 m/s. Therefore, a 40 mm pipe is acceptable, the line designation is amended to 40-SLG-1660, and $D_i = 40$ mm, $D_o = 50$ mm, and $V = 2.19$ m/s.

At 23.9°C, $\nu = 8.94 \times 10^{-7} \text{ m}^2/\text{s}$ and the Darcy-Weisbach equation is used to calculate the pressure drop through the piping.

Ref. p. 3-8.

$$h_L = \left[\left(\frac{fL}{D_i} + \Sigma K \right) \frac{V^2}{2g} \right]$$

Ref. p. 3-8.

$$R_e = \frac{D_i V}{\nu} = \frac{(0.040 \text{ m})(2.19 \text{ m/s})}{8.94 \times 10^{-7} \text{ m}^2/\text{s}}$$

$$= 9.8 \times 10^4 - \textit{turbulent flow}$$

$$\epsilon = 0.061 \text{ mm from Table 3-1}$$

$$\epsilon/D_i = \frac{0.061 \text{ mm}}{40 \text{ mm}} = 0.0015$$

Therefore, $f = 0.024$ from the Moody Diagram (Figure 3-1). From Sketch C-9, the sum of the minor loss coefficients from Table 3-3:

Table C-14 Minor Losses for 40-SLG-1660	
Minor Loss	K
1 ball valve (open)	4.5
1 tee-branch flow	1.8
3 x 90° elbows	3(0.9)
2 x 45° bends	2(0.5)
1 swing check valve	2.5
1 exit	1.0
$\Sigma K =$	12.5

$$h_L = \left(\frac{fL}{D_i} + \Sigma K \right) \frac{V^2}{2g}$$

$$= \left[\frac{(0.024)(22.0 \text{ m})}{0.040 \text{ m}} + 12.5 \right] \frac{(2.19 \text{ m/s})^2}{2 (9.81 \text{ m/s}^2)}$$

$$= 6.28 \text{ m (61.7 kPa)}$$

The maximum waste sludge pump head is 250 kPa which is adequate to overcome the piping pressure drop.

PRESSURE INTEGRITY

The design pressure is equal to the maximum pump head = 250 kPa. No potential pressure transients exist. An external corrosion allowance of 2 mm and an internal erosion allowance of 2 mm are to be designed. Pressure integrity is acceptable if the minimum wall thickness meets ASME 31.3 code. For ASTM A 53, Grade A pipe, ASME B31.3 tables provide $S = 110$ MPa, $E = 1.0$, and $y = 0.4$.

Ref. p. 3-15.

$$t_m = t + A = \frac{P D_o}{2 (S E + P y)} + A$$

$$t_m = \frac{(0.250 \text{ MPa})(50 \text{ mm})}{2[(110 \text{ MPa})(1.0) + (0.250 \text{ MPa})(0.4)]}$$

$$+ 4 \text{ mm} = 4.06 \text{ mm}$$

The commercial wall thickness tolerance for seamless rolled pipe is +0, -12½%.

$$t_{NOM} = \frac{4.06 \text{ mm}}{1.0 - 0.125} = 4.64 \text{ mm}$$

Nominal 40 mm pipe has a thickness of 5 mm; therefore, the 40 mm piping satisfies pressure integrity.

LOADS

Based on the previous calculations for this site, the above ground piping segment will be acceptable for the loads applied. The below grade piping will be subject to internal and external pressure loads.

Step 1. Internal Pressure - See the pressure integrity calculations for the design pressure.

Step 2. External Pressure/Loads - The external pressure/loads will result from the earth load and perhaps a wheel load, a sustained load and an occasional load respectively.

Earth Load:

Ref. p. 2-7.

$$F_E = \frac{\omega H}{a} = \frac{(1,922 \text{ kg/m}^3)(0.9 \text{ m})}{\left(102 \frac{\text{kg/m}^2}{\text{kPa}}\right)} = 17.0 \text{ kPa}$$

Wheel Load:

Ref. pp. 2-9 - 2-10.

$$F_W = \frac{C R P F}{b D_o} = \frac{(0.098 \text{ /m})(7,257 \text{ kg})(1.5)}{\left(0.031 \frac{\text{kg/m}}{\text{kPa}}\right)(50 \text{ mm})} = 688 \text{ kPa}$$

STRESS ANALYSIS

Step 1. Internal Stresses - Line 40-SLG-1660 meets the pressure integrity requirements; therefore, the limits of stress due to internal pressure are satisfied.

Step 2. External Stresses - For sustained loads, the sum of the longitudinal stresses must be less than the allowable stress at the highest operating temperature:

Ref. p. 3-17.

$$\Sigma S_L \leq S_h$$

For occasional loads, the sum of the longitudinal stresses due to both sustained and occasional loads must be less than 1.33 S_h:

$$\Sigma S'_L \leq 1.33 S_h$$

With below grade placement, the piping is continuously supported and sustained loads are a result of longitudinal pressure and earth pressure. Therefore, the check for longitudinal stresses from sustained loads is as follows.

Ref. p. 3-17.

$$\Sigma S_L = \frac{P D_o}{4 t} + F_E = \frac{(275 \text{ kPa})(50 \text{ mm})}{4 (5 \text{ mm})} + 17.0 \text{ kPa} = 705 \text{ kPa}$$

From ASME B31.3, Table A-1, S_h = 110 MPa. For 40-SLG-1660, ΣS_L ≤ S_h; therefore, the pipe is acceptable for sustained loads.

The only additional occasional load is a wheel load. Therefore, the check for occasional loads is as follows.

Ref. p. 3-17.

$$\Sigma S'_L = \Sigma S_L + F_W = 705 \text{ kPa} + 688 \text{ kPa} = 1.39 \text{ MPa}$$

For 40-SLG-1660, ΣS'_L ≤ 1.33S_h; therefore, the pipe is acceptable for the anticipated occasional loads.

FLANGE CONNECTIONS

The flange connections will be carbon steel welding neck flanges, raised face, and 1.03 MPa rated (class 150) pursuant to ASME B16.5.

Operating bolt load:

Ref. pp. 3-21 - 3-22.

$$W_{ml} = 0.785 G^2 P + (2 b)(3.14 G m P)$$

from ASME B16.5, Table E1, for a flange on a 40 mm pipe, G = 48.7 mm and b = 12.2 mm;
from Table 3-5, m = 0.5 for an elastomeric gasket;

$$W_{m1} = (0.785)(48.7 \text{ mm})^2(0.250 \text{ MPa}) \\ + (2)(12.2 \text{ mm})(3.14)(48.7 \text{ mm})(0.5)(0.250 \text{ MPa}) \\ = 932 \text{ N}$$

$$A_{m1} = \frac{W_{m1}}{S}$$

from ASME B31.3, Table A-2, for alloy steel ASTM A 193, B7M, $S_b = 137 \text{ MPa}$.

$$A_{m1} = \frac{932 \text{ N}}{137 \text{ MPa}} = 6.80 \text{ mm}^2$$

Initial load during assembly:

Ref. p. 3-21.

$$W_{m2} = 3.14 b G y$$

from Table 3-5, $y = 0$; therefore, $W_{m2} = 0$.

Thus the design is controlled by the operating condition and the bolting is selected to match the required bolt cross-sectional area:

Ref. p. 3-23.

$$A_s = 0.7854 \left(D - \frac{0.9743}{N} \right)^2$$

select 14 mm bolts with a coarse thread (pitch = $1/N = 2$)

$$A_s = 0.7854 \left[(14) - \left(\frac{0.9743}{1/2} \right) \right]^2 = 114 \text{ mm}^2$$

$A_s > A_{m1}$; therefore, the selected bolting is acceptable.

CATHODIC PROTECTION

(See TM 5-811-7 Electrical Design, Cathodic Protection for Guidance)

40-SLG-1660 is a zinc coated steel pipe installed below grade; therefore, cathodic protection is required. Due to the small size of the structure, galvanic protection is selected. Existing data and the design bases are reviewed to obtain the following design data:

average soil resistivity (ρ) = 4,500 Ω -cm,
90 % coating (zinc) efficiency is anticipated,
20 year life is desired,
21.5 ma/m² is required, and
packaged type magnesium anodes are to be specified.

Step 1. The total area of the underground piping is calculated.

$$A = \pi D_o L = \pi (0.050 \text{ m})(20.3 \text{ m}) \\ = 3.19 \text{ m}^2$$

and the total piping area to be protected is determined.

$$A_T = A (0.10) = (3.19 \text{ m}^2) (0.10) = 0.319 \text{ m}^2$$

Step 2. The maximum protective current, I, is:

$$I = (21.5 \text{ ma/m}^2) A_T \\ = (21.5 \text{ ma/m}^2)(0.319 \text{ m}^2) = 68.6 \text{ ma}$$

Step 3. The weight of the anode based on a 20 year life is calculated (see TM 5-811-7, eqn. C-1).

$$W = \frac{Y S I}{E} \\ = \frac{(20 \text{ years})(4.0 \text{ kg/A-yr})(0.0069 \text{ A})}{0.50} = 1.10 \text{ kg}$$

Step 4. A standard, package anode will be used so this type of anode is reviewed to determine how many anodes are required to satisfy the current. The weight of a standard packaged magnesium anode is 1.4 kg (see TM 5-811-7, Table C-4). The current output to ground is calculated for the anode (see TM 5-811-7, eqn. C-2).

$$i = \frac{C f y}{P}$$

where:

C = 120,000 for a well coated structure (see TM 5-811-7)

f = 0.53 (see TM 5-811-7, Table C-4)

y = 1.0 (see TM 5-811-7, Table C-5)

P = average soil resistivity = 4,500 Ω-cm

$$i = \frac{C f y}{P} = \frac{(120,000) (0.53) (1.0)}{4,500 \Omega\text{-cm}} = 14.1 \text{ ma}$$

Step 5. The number of anodes required is determined (see TM 5-811-7, eqn. C-3).

$$\frac{I}{i} = \frac{6.85 \text{ ma}}{14.1 \text{ ma}} = 0.49$$

The 1.4 kg anode satisfies the current output requirements. Smaller packages anodes are not readily available.

THRUST BLOCKS

(see TI 814-03, Water Distribution, for guidance)

Thrust blocks are required at the 90° and 45° bends. Concrete thrust blocks will be used so the area of the thrust block will be determined. Because the pipes are already cathodically protected, additional protection or insulation between the concrete and the pipe is not required. The thrust at each bend is calculated first (see TI 814-03, eqn. C-1).

$$T = 2 \pi \left(\frac{D_o}{2} \right)^2 P \sin \left(\frac{\Delta}{2} \right)$$

where:

T = thrust generated, N

D_o = outer diameter of pipe, mm

P = design pressure, MPa

Δ = angle of bend, degree

For the 90° bends:

$$T_{90} = 2 \pi \left(\frac{50 \text{ mm}}{2} \right)^2 (0.250 \text{ MPa}) \sin \left(\frac{90}{2} \right) = 694 \text{ N}$$

For the 45° bends:

$$T_{45} = 2 \pi \left(\frac{50 \text{ mm}}{2} \right)^2 (0.250 \text{ MPa}) \sin \left(\frac{45}{2} \right) = 376 \text{ N}$$

The area of the thrust block is calculated by (see TI 814-03 equation C-2):

$$A_{TB} = \frac{T}{a} f_s$$

where:

A_{TB} = area of thrust block (mm²)

T = thrust generated, N

a = safe soil bearing value, MPa; assume 20.5 MPa

f_s = safety factor, typically 1.5

For the 90° bends:

$$A_{90TB} = \frac{694 \text{ N}}{20.5 \text{ MPa}} 1.5 = 51 \text{ mm}^2$$

For the 45° bends:

$$A_{45TB} = \frac{376 \text{ N}}{20.5 \text{ MPa}} 1.5 = 28 \text{ mm}^2$$

- i. **Line XXX-PYS-101**
 Chemical Feed from Bulk Polymer to Polymer Day Tank

Referencing Sketch C-10:

Polymer demand = 0.3785 m³/day;
 therefore, assuming a 15 minute fill
 the maximum flow rate,
 $Q = 2.628 \times 10^{-2} \text{ m}^3/\text{min} = 4.38 \times 10^{-4} \text{ m}^3/\text{s}$

Existing run = 50.0 m
 New run = 25.0 m

Maximum elevation change = 3.0 m

Existing polymer pump head = 8.1 m (79.5 kPa)

- Fittings:
 6 x 90° elbows
 1 branch Tee
 3 isolation ball valves

MATERIAL OF CONSTRUCTION

The existing polymer line is 25 mm diameter, schedule 80 PVC. The polymer makeup is proprietary but is approximately 99% water. From a site inspection there is no evidence of existing pipe erosion or breakdown. Therefore, the extension or new pipe run will also use 25

mm diameter, schedule 80 PVC with electrical heat tracing and insulation to maintain 20°C (maximum temperature differential will be 45°C).

PIPE SIZING/PRESSURE DROP

Step 1. Using the same size nominal pipe size of the existing pipe results in an actual D_i of 24.3 mm. Therefore, the liquid velocity is:

$$V = \frac{Q}{A} = \frac{Q}{\frac{\pi D_i^2}{4}} = \frac{4.38 \times 10^{-4} \text{ m}^3/\text{s}}{\frac{\pi (0.0243 \text{ m})^2}{4}} = 0.94 \text{ m/s}$$

The actual velocity, 0.94 m/s, is somewhat slower than the acceptable range, 2.1 ± 0.9 m/s, but the pressure drop will be checked using this velocity due to the limited pump head. The line designation is amended to 25-PYS-101.

Step 2. At 23.9°C, $\nu = 8.94 \times 10^{-7} \text{ m}^2/\text{s}$ and the Darcy-Weisbach equation is used to calculate the pressure drop through the piping.

Ref. p. 3-8.

$$h_L = \left[\left(\frac{fL}{D_i} + \Sigma K \right) \frac{V^2}{2g} \right]$$

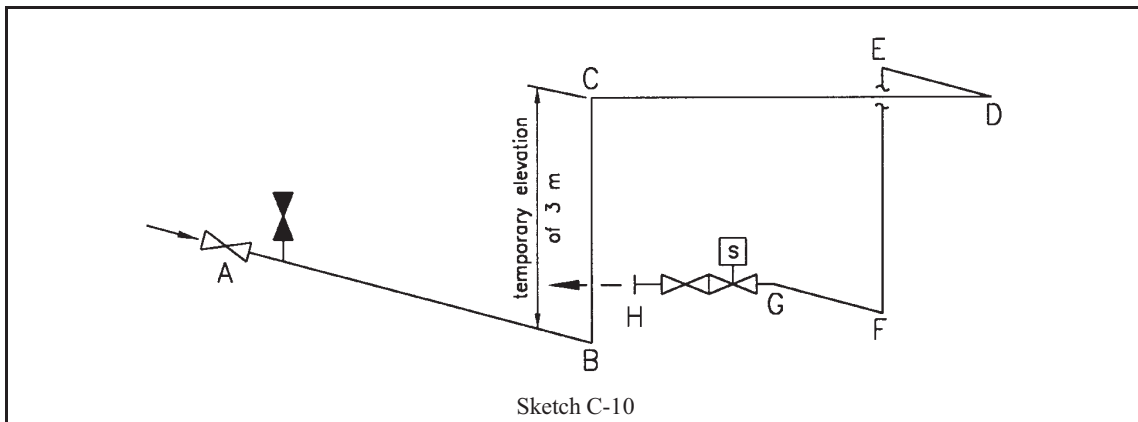

Sketch C-10

Ref. p. 3-8.

$$R_e = \frac{D_i V}{\nu} = \frac{(0.0243 \text{ m})(0.94 \text{ m/s})}{8.94 \times 10^{-7} \text{ m}^2/\text{s}}$$

$$= 2.56 \times 10^4 - \textit{turbulent flow}$$

$$\epsilon = 0.0015 \text{ mm from Table 3-1}$$

$$\epsilon/D_i = \frac{0.0015 \text{ mm}}{24.3 \text{ mm}} = 0.00006$$

Therefore, $f = 0.024$ from the Moody Diagram (Figure 3-1). From Sketch C-10, the sum of the minor loss coefficients from Table 3-3:

Table C-15 Minor Losses for 25-PYS-101	
Minor Loss	K
3 x ball valves (open)	3(4.5)
1 tee-flow through	0.6
6 x 90° elbows	6(0.5)
1 exit	1.0
$\Sigma K =$	18.1

$$h_L = \left(\frac{fL}{D_i} + \Sigma K \right) \frac{V^2}{2g}$$

$$= \left[\frac{(0.024)(75.0 \text{ m})}{0.0243 \text{ m}} + 18.1 \right] \frac{(0.94 \text{ m/s})^2}{2 (9.81 \text{ m/s}^2)}$$

$$= 4.15 \text{ m}$$

The total pump head required is the sum of the piping losses, h_L , and the temporary elevation of 3 m over the walkway. Therefore, the total pump head required is

7.15 m and the actual pump head available is 8.1 m. The pipe should not be sized smaller (even though the flow is below the desired range) unless the pump is to be replaced.

PRESSURE INTEGRITY

The design pressure is equal to the required pump head = 79.5 kPa. A pressure transient exists due to potential water hammer conditions from the solenoid valve at the tank inlet. Therefore, the transient will be minimized by having the valve be a “slow-opening” valve.

Ref. p. 3-6.

$$V_w = \left(\frac{E_s}{n_1 \rho} \right)^{0.5}$$

$$= \left(\frac{2,180 \text{ MPa}}{(10^{-6} \text{ MPa/Pa})(998.2 \text{ kg/m}^3)} \right)^{0.5} = 1,478 \text{ m/s}$$

and

$$t_c = \frac{2L}{V_w} = \frac{2(75 \text{ m})}{1,478 \text{ m/s}} = 0.10 \text{ s}$$

A gradual valve closure, $t_v = 20 \times t_c = 2 \text{ s}$ is to be provided. Therefore, the pressure rise is determined.

Ref. p. 3-6.

$$P_i' = \frac{2 \rho L V n_1}{t_v}$$

$$= \frac{2 (998.2 \text{ kg/m}^3)(75 \text{ m})(0.94 \text{ m/s})(10^{-3} \text{ kPa/Pa})}{2 \text{ s}}$$

$$= 70.4 \text{ kPa}$$

Because the pressure transient is significant (>10% of the operating pressure), it must be included as part of the design pressure.

$$P = 79.5 \text{ kPa} + 70.4 \text{ kPa} = 150 \text{ kPa}$$

From ASME B31.3, the minimum wall thickness, t_m , for thermoplastic pipe is:

$$t_m = \frac{P D_o}{(2 S + P)}$$

S = hydrostatic design stress = 13.8 MPa (reference ASME B31.3, Table B-1)

$$t_m = \frac{(0.150 \text{ MPa})(24.3 \text{ mm})}{[2 (13.8 \text{ MPa}) + (0.150 \text{ MPa})]} = 0.131 \text{ mm}$$

Nominal 25 mm, schedule 80 pipe has a thickness of 4.5 mm; therefore, the 25 mm pipe section satisfies pressure integrity.

LOADS

Step 1. Pressure - See the pressure integrity calculations for the design pressure.

Step 2. Weight - The 25-PYS-101 dead weight is the piping and the insulation. Because the piping section will be continuously full, the weight of the fluid will be determined as part of the dead weight.

The insulation for the piping was selected pursuant to CEGS 15250 to be flexible cellular (elastomeric) foam, 9.525 mm thick and with a specific weight of approximately 314 N/m³.

$$\begin{aligned} W &= W_P + W_i + W_L \\ &= A_P \delta_{PVC} + \pi \delta_i T_i (D_o + T_i) + \frac{\pi}{4} D_i^2 \delta_L \end{aligned}$$

$$\begin{aligned} W &= (4.12 \times 10^{-4} \text{ m}^2)(13,517 \text{ N/m}^3) \\ &\quad + \pi (314 \text{ N/m}^3)(9.525 \text{ mm}) \times \\ &\quad (32 \text{ mm} + 9.525 \text{ mm})(10^{-6} \text{ m}^2/\text{mm}^2) \\ &\quad + \frac{\pi}{4} (24.3 \text{ mm})^2 (9,795 \text{ N/m}^3)(10^{-6} \text{ m}^2/\text{mm}^2) \\ &= 10.5 \text{ N/m; uniformly distributed} \end{aligned}$$

Step 3. Wind - From TI 809-01, the basic wind speed is 40.2 m/s. The plant is located in an area with exposure C (open terrain with scattered obstructions having heights less than 10 m) so a gust factor of 33% is added to the basic wind speed to determine the design wind speed, V_{dw} .

$$V_{dw} = (40.2 \text{ m/s}) (1.33) = 53.5 \text{ m/s}$$

(or 192.6 km/hr, > minimum of 161 km/hr)

Ref. p. 2-7.

$$\begin{aligned} R_e &= C_{w2} V_W D_o \\ &= (6.87)(53.5 \text{ m/s})[32 \text{ mm} + 2 (9.525 \text{ mm})] \\ &= 1.9 \times 10^4 \end{aligned}$$

Using the R_e value in the ASCE 7 drag coefficient chart and assuming an infinite circular cylinder (i.e., L:D > 5:1), $C_D = 1.21$.

Ref. p. 2-7.

$$\begin{aligned} F_W &= C_{w1} V_W^2 C_D D_o \\ &= (2.543 \times 10^{-6})(53.5 \text{ m/s})^2 (1.21) \times \\ &\quad [32 \text{ mm} + 2 (9.525 \text{ mm})] = 0.45 \text{ N/m} \end{aligned}$$

The design wind loads are uniformly distributed horizontally (i.e., perpendicular to the weight load).

Step 4. Snow - From TI 809-01, the basic snow load is 239 kPa.

Ref. p. 2-8.

$$W_s = \frac{1}{2} n D_o S_L$$

$$= \frac{1}{2} (10^{-3} \text{ m/mm}) [32 \text{ mm} + 2 (9.525 \text{ mm})] \times (239 \text{ kPa}) = 6.1 \text{ N/m}$$

The design snow loads are uniformly distributed and additive to the weight.

Step 5. Ice - No data is readily available; therefore, assume a maximum buildup of 12.5 mm.

Ref. p. 2-8.

$$W_I = \pi n_3 S_I t_I (D_o + t_p)$$

$$= \pi (10^{-6} \text{ m}^2/\text{mm}^2) (8,820 \text{ N/m}^3) (12.5 \text{ mm}) \times [32 \text{ mm} + 2 (9.525 \text{ mm}) + 12.5 \text{ mm}] = 22.0 \text{ N/m}$$

The design ice loads are uniformly distributed and additive to the weight.

Step 6. Seismic - From TM 5-809-10, the facility is located in a seismic zone 0; therefore, the seismic loading is not applicable.

Step 7. Thermal - Thermal loads will be examined under the stress analysis. The coefficient of thermal expansion
 $= (54 \times 10^{-6} \text{ mm/mm-}^\circ\text{C}) (45^\circ\text{C}) = 2.43 \times 10^{-3} \text{ mm/mm}$.

STRESS ANALYSIS

Step 1. Internal Stresses - 25-PYS-101 meets the pressure integrity requirements; therefore, the limits of stress due to internal pressure are satisfied.

Step 2. External Stresses - In accordance with ASME B31.3, for thermoplastic piping the sum of the external stresses resulting from loads must be less than $1.33 S_h$:

Ref. p. 3-17.

$$\Sigma S_L \leq 1.33 S_h$$

From ASME B31.3, Table A-1, $S_h = 13.8 \text{ MPa}$.

$$1.33 S_h = 1.33 (13.8 \text{ MPa}) = 18.4 \text{ MPa}$$

To determine the longitudinal stress due to uniformly distributed loads such as weight, the support spans and spacing must first be determined. Referring to Figure C-3, Piping Layout Plan, all three chemical feed lines will be run parallel and will be supported on a pipe rack. As the smallest diameter pipe of the three chemical feed lines, 25-PYS-101 will control the support spacing. From manufacturer's data (see Table 5-4), the maximum support spacing, L, for 25 mm PVC pipe is 1.7 m; see Figure C-4, Piping Layout Plan with Support Locations.

Ref. p. 3-17.

$$\Sigma S_L = 0.1 \frac{W L^2}{n Z}$$

Ref. p. 3-25.

$$Z = \frac{\pi}{32} \frac{D_o^4 - D_i^4}{D_o}$$

$$= \frac{\pi}{32} \frac{(32 \text{ mm})^4 - (24.3 \text{ mm})^4}{(32 \text{ mm})} = 2,147 \text{ mm}^3$$

It is assumed that snow and ice will not occur concurrently and since the ice loading is greater than the snow loading, the sustained loads are equal to the weight of the piping system and the ice.

Ref. p. 3-17.

$$\Sigma S_L = (0.1) \frac{[(10.5 \text{ N/m}) + (22.0 \text{ N/m})](1.7 \text{ m})^2}{(10^{-3} \text{ m/mm})(2,147 \text{ mm}^3)}$$

$$= 4.4 \text{ MPa}$$

For 25-PYS-101, $\Sigma S_L \leq 1.33 S_h$; therefore, the system is acceptable for the design stress loading.

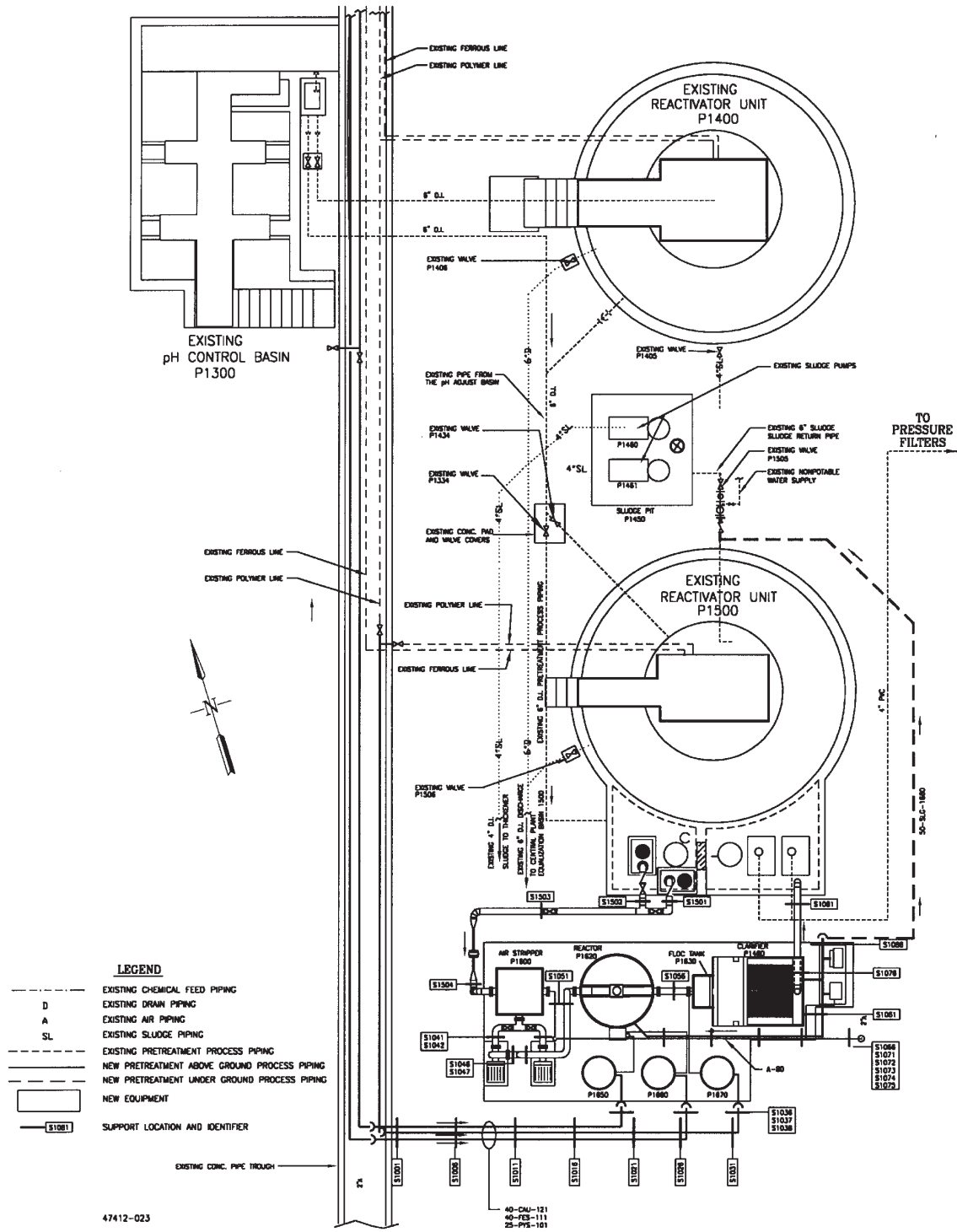
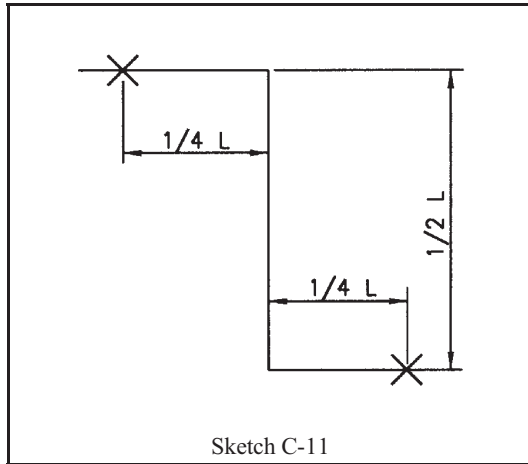

Figure C-4. Piping Layout Plan with Support Locations

Step 3. Stresses are imposed upon the piping system due to thermal expansion and contraction. To ensure that thermoplastic piping systems have sufficient flexibility to prevent these failures, a minimum offset is required between a bend and a restrained anchor. For 25-PYS-101, there are a series of Z-shaped arrangements: A-B-C-D, C-D-E-F, and E-F-G-H; see Sketch C-10.



Referencing Sketch C-11, for Z-shapes:

$$L = \frac{1 \text{ m}}{1,000 \text{ mm}} \left(\frac{3 E D_o \epsilon}{S} \right)^{0.5}$$

where:

- L = offset pipe length, m
- E = modulus of elasticity = 2,895 MPa
- S = allowable stress = 13.8 MPa
- D_o = outer pipe diameter = 32 mm
- ε = thermal expansion coefficient = 2.43 x 10⁻³ mm/mm

For pipe section A-B-C-D with a length of approximately 3 m:

$$L_{ABCD} = \frac{1 \text{ m}}{1,000 \text{ mm}} x \left(\frac{3(2,895 \text{ MPa})(32 \text{ mm})[(2.43 \times 10^{-3} \frac{\text{mm}}{\text{mm}})(3,000 \text{ mm})]}{13.8 \text{ MPa}} \right)^{0.5}$$

= 0.38 m, minimum.

Since 1/2 (B-C) = 1/2 (3 m) > L_{ABCD}, the flexibility of the piping segment is acceptable. The restraints (anchors) should be located at a minimum 1/4 L = 1/4 (0.38 m) = 0.10 m from the bends. That is, a pipe guide should be located at support no. S1006 and another within the existing pipe trench - field check rack location.

For pipe section C-D-E-F with a length of approximately 10.7 m:

$$L_{CDEF} = \frac{1 \text{ m}}{1,000 \text{ mm}} x \left(\frac{3(2,895 \text{ MPa})(32 \text{ mm})[(2.43 \times 10^{-3} \frac{\text{mm}}{\text{mm}})(10,700 \text{ mm})]}{13.8 \text{ MPa}} \right)^{0.5}$$

= 0.72 m, minimum.

Since 1/2 (D-E) = 1/2 (10.7 m) > L_{CDEF}, the flexibility of the piping segment is acceptable. The anchors should be located at a minimum 1/4 L = 1/4 (0.72 m) = 0.36 m from the bends. That is, a pipe guide should be located at support no. S1026 and a vertical guide 0.36 m from bottom of pipe (BOP) on support no. S1038.

For pipe section E-F-G-H with a length of approximately 1.5 m:

$$L_{EFGH} = \frac{1 \text{ m}}{1,000 \text{ mm}} \times \left(\frac{3(2,895 \text{ MPa})(32 \text{ mm})[(2.43 \times 10^{-3} \frac{\text{mm}}{\text{mm}})(1,500 \text{ mm})]}{13.8 \text{ MPa}} \right)^{0.5}$$

$$= 0.27 \text{ m, minimum.}$$

Since $\frac{1}{2} (F-G) = \frac{1}{2} (3 \text{ m}) > L_{EFGH}$, the flexibility of the piping segment is acceptable. The anchors should be located at a minimum $\frac{1}{4} L = \frac{1}{4} (0.27 \text{ m}) = 0.07 \text{ m}$ from the bends. That is, relocate the vertical pipe guide established on S1038 at 0.36 m BOP down to $\frac{1}{2}$ the vertical run, $\frac{1}{2} (2 \text{ m}) = 1 \text{ m}$ BOP. Also locate the support for the solenoid valve at 0.07 m from the bend at G.

j. Line 15-PYS-102
Chemical Feed from Polymer Day Tank to Polymer Controlled Volume Pump

The controlled volume pump has a 15 mm female taper threaded connection. The piping from the pump to the process injection point is supplied by the process unit manufacturer and is 15 mm SAE 100R7 hose. Therefore, 15-PYS-102 is selected to be identical to the process hose: 15 mm SAE 100R7 hose (thermoplastic tube, synthetic-fiber reinforcement, thermoplastic cover) with 15 mm male taper threaded end connections, built-in fittings. Minimum hose length is 3 m.

Ensure that the process engineer, or the engineer that is specifying the day tanks, designs the polymer day tank with the proper discharge port - 15 mm taper threaded nozzle, female.

k. Line XXX-FES-111
Chemical Feed from Bulk Ferrous Sulfate to Ferrous Sulfate Day Tank

Referencing Sketch C-12:

Ferrous sulfate demand = 0.757 m³/day;
therefore, assuming a 15 minute fill the maximum flow rate, $Q = 5.05 \times 10^{-2} \text{ m}^3/\text{min} = 8.42 \times 10^{-4} \text{ m}^3/\text{s}$

Existing run = 30.0 m
New run = 50.0 m

Maximum elevation change = -0.5 m (the elevation difference between E and A is 0.5 m down)

Existing ferrous sulfate pump head = 3.05 m (29.9 kPa)

- Fittings:
- 8 x 90° elbows
 - 1 x Tee, branch flow
 - 1 x Tee, flow-through
 - 4 x isolation ball valves

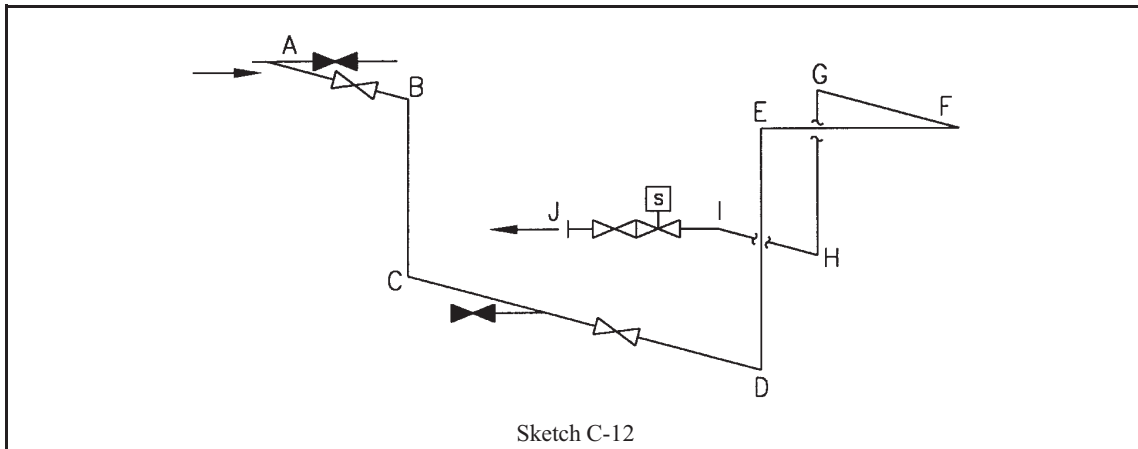

Sketch C-12

MATERIAL OF CONSTRUCTION

The existing ferrous sulfate line is 40 mm diameter, schedule 80 PVC. The ferrous sulfate is 20% solution with a specific gravity, s.g. = 1.18. Ferrous sulfate is compatible with PVC and from a site inspection there is no evidence of existing pipe erosion or breakdown. Therefore, the extension or new pipe run will also use 40 mm diameter, schedule 80 PVC with electrical heat tracing and insulation to maintain 20°C (maximum temperature differential will be 45°C).

PIPE SIZING/PRESSURE DROP

Step 1. Using the same size nominal pipe size of the existing pipe results in an actual D_i of 40 mm. Therefore, the liquid velocity is:

$$V = \frac{Q}{A} = \frac{Q}{\frac{\pi}{4} D_i^2}$$

$$= \frac{8.42 \times 10^{-4} \text{ m}^3/\text{s}}{\frac{\pi}{4} (0.040 \text{ m})^2} = 0.67 \text{ m/s}$$

The actual velocity, 0.67 m/s, is somewhat slower than the acceptable range, 2.1 ± 0.9 m/s, but the pressure drop will be checked using this velocity due to the limited pump head. The line designation is amended to 40-FES-111.

Step 2. At 23.9°C, $v = 1.05 \times 10^{-6} \text{ m}^2/\text{s}$ and the Darcy-Weisbach equation is used to calculate the pressure drop through the piping.

Ref. p. 3-8.

$$h_L = \left[\left(\frac{fL}{D_i} + \Sigma K \right) \frac{V^2}{2g} \right]$$

Ref. p. 3-8.

$$R_e = \frac{D_i V}{\nu} = \frac{(0.040 \text{ m})(0.67 \text{ m/s})}{1.05 \times 10^{-6} \text{ m}^2/\text{s}}$$

$$= 2.55 \times 10^4 - \text{turbulent flow}$$

$$\epsilon = 0.0015 \text{ mm from Table 3-1}$$

$$\epsilon/D_i = \frac{0.0015 \text{ mm}}{40 \text{ mm}} = 0.00004$$

Therefore, $f = 0.024$ from the Moody Diagram (Figure 3-1). From Sketch C-12, the sum of the minor loss coefficients from Table 3-3:

Minor Loss	K
4 x ball valves (open)	4(4.5)
1 tee-branch flow	1.8
1 tee-flow through	0.6
8 x 90° elbows	8(0.5)
1 exit	1.0
$\Sigma K =$	25.4

$$h_L = \left(\frac{fL}{D_i} + \Sigma K \right) \frac{V^2}{2g}$$

$$= \left[\frac{(0.024)(80.0 \text{ m})}{0.040 \text{ m}} + 25.4 \right] \frac{(0.67 \text{ m/s})^2}{2 (9.81 \text{ m/s}^2)}$$

$$= 1.68 \text{ m}$$

The total pump head required is the sum of the piping losses, h_L , and the elevation gain of -0.5 m. Therefore, the total pump head required is $1.98 \text{ m} + (-0.5 \text{ m}) = 1.48 \text{ m}$ and the actual pump head available is 3.05 m. The pipe should not be sized smaller (even though the flow is below the desired range) unless the pump is to be replaced.

PRESSURE INTEGRITY

The design pressure is equal to the required pump head = 29.9 kPa. A pressure transients exists due to potential water hammer conditions from the solenoid valve at the tank inlet. Therefore, the transient will be minimized by having the valve be a “slow-opening” valve.

Ref. p. 3-6.

$$V_w = \left(\frac{E_s}{n_1 \rho} \right)^{0.5}$$

$$= \left(\frac{2,180 \text{ MPa}}{(10^{-6} \text{ MPa/Pa})(1,178 \text{ kg/m}^3)} \right)^{0.5} = 1,360 \text{ m/s}$$

and

$$t_c = \frac{2 L}{V_w} = \frac{2 (80 \text{ m})}{1,360 \text{ m/s}} = 0.12 \text{ s}$$

A gradual valve closure, t_v , of 2 s is to be provided. Therefore, the pressure rise is determined.

Ref. p. 3-6.

$$P_i' = \frac{2 \rho L V n_1}{t_v} =$$

$$\frac{2 (1,178 \text{ kg/m}^3)(80 \text{ m})(0.67 \text{ m/s})(10^{-3} \text{ kPa/Pa})}{2 \text{ s}}$$

$$= 63.1 \text{ kPa}$$

Because the pressure transient is significant (>10% of the operating pressure), it must be included as part of the design pressure.

$$P = 29.9 \text{ kPa} + 63.1 \text{ kPa} = 93 \text{ kPa}$$

From ASME B31.3, the minimum wall thickness, t_m , for thermoplastic pipe is:

$$t_m = \frac{P D_o}{(2 S + P)}$$

S = hydrostatic design stress = 13.8 MPa (reference ASME B31.3, Table B-1)

$$t_m = \frac{(0.093 \text{ MPa})(40 \text{ mm})}{[2 (13.8 \text{ MPa}) + (0.093 \text{ MPa})]}$$

$$= 0.134 \text{ mm}$$

Nominal 40 mm, schedule 80 pipe has a thickness of 5.1 mm; therefore, the 40 mm pipe section satisfies pressure integrity.

LOADS

Step 1. Pressure - See the pressure integrity calculations for the design pressure.

Step 2. Weight - The 40-FES-111 dead weight is the piping and the insulation. Because the piping section will be continuously full, the weight of the fluid will be determined as part of the dead weight.

The insulation for the piping was selected pursuant to GS 15250 to be flexible cellular (elastomeric) foam, 9.525 mm thick and with a specific weight of approximately 314 N/m³.

$$W = W_p + W_i + W_L$$

$$= A_p \delta_{pvc} + \pi \delta_i T_i (D_o + T_i) + \frac{\pi}{4} D_i^2 \delta_L$$

$$\begin{aligned}
 W &= (6.89 \times 10^{-4} m^2) (13,517 N/m^3) \\
 &+ \pi (314 N/m^3)(9.525 mm) \times \\
 &(50 mm + 9.525 mm)(10^{-6} m^2/mm^2) \\
 &+ \frac{\pi}{4} (40 mm)^2(11,560 N/m^3)(10^{-6} m^2/mm^2) \\
 &= 24.4 N/m; \text{ uniformly distributed}
 \end{aligned}$$

Step 3. Wind - From TI 809-01, the basic wind speed is 40.2 m/s. The plant is located in an area with exposure C (open terrain with scattered obstructions having heights less than 10 m) so a gust factor of 33% is added to the basic wind speed to determine the design wind speed, V_{dw} .

$$\begin{aligned}
 V_{dw} &= (40.2 m/s) (1.33) = 53.5 m/s \\
 &(\text{or } 192.6 km/hr, > \text{ minimum of } 161 km/hr)
 \end{aligned}$$

Ref. p. 2-7.

$$\begin{aligned}
 R_e &= C_{w2} V_w D_o \\
 &= (6.87)(53.5 m/s)[50 mm + 2 (9.525 mm)] \\
 &= 2.54 \times 10^4
 \end{aligned}$$

Using the R_e value in the ASCE 7 drag coefficient chart and assuming an infinite circular cylinder (i.e., L:D > 5:1), $C_D = 1.21$.

Ref. p. 2-7.

$$\begin{aligned}
 F_w &= C_{w1} V_w^2 C_D D_o \\
 &= (2.543 \times 10^{-6})(53.5 m/s)^2(1.21) \times \\
 &[50 mm + 2 (9.525 mm)] = 0.61 N/m
 \end{aligned}$$

The design wind loads are uniformly distributed horizontally (i.e., perpendicular to the weight load).

Step 4. Snow - From TI 809-01, the basic snow load is 239 kPa.

Ref. p. 2-8.

$$\begin{aligned}
 W_s &= \frac{1}{2} n D_o S_L = \\
 &\frac{1}{2} (10^{-3} m/mm)[50 mm + 2(9.525 mm)](239 kPa) \\
 &= 8.25 N/m
 \end{aligned}$$

The design snow loads are uniformly distributed and additive to the weight.

Step 5. Ice - No data is readily available; therefore, assume a maximum buildup of 12.5 mm.

Ref. p. 2-8.

$$\begin{aligned}
 W_I &= \pi n_3 S_I t_I (D_o + t_I) \\
 &= \pi (10^{-6} m^2/mm^2)(8,820 N/m^3)(12.5 mm) \times \\
 &[50 mm + 2(9.525 mm) + 12.5 mm] = 28.2 N/m
 \end{aligned}$$

The design ice loads are uniformly distributed and additive to the weight.

Step 6. Seismic - From TM 5-809-10, the facility is located in a seismic zone 0; therefore, the seismic loading is not applicable.

Step 7. Thermal - Thermal loads will be examined under the stress analysis. The coefficient of thermal expansion = $(54 \times 10^{-6} mm/mm-^\circ C) (45^\circ C) = 2.43 \times 10^{-3} mm/mm$.

STRESS ANALYSIS

Step 1. Internal Stresses - 40-FES-111 meets the pressure integrity requirements; therefore, the limits of stress due to internal pressure are satisfied.

Step 2. External Stresses - In accordance with ASME B31.3, for thermoplastic piping the sum of the external stresses resulting from loads must be less than $1.33 S_h$:

Ref. p. 3-17.

$$\Sigma S_L \leq 1.33 S_h$$

From ASME B31.3, Table A-1, $S_h = 13.8 \text{ MPa}$.

$$1.33S_h = 1.33 (13.8 \text{ MPa}) = 18.4 \text{ MPa}$$

To determine the longitudinal stress due to uniformly distributed loads such as weight, the support spans and spacing must first be determined. Referring to Figure C-3, Piping Layout Plan, all three chemical feed lines will be run parallel and will be supported on a pipe rack. As the smallest diameter pipe of the three chemical feed lines, 40-FES-111 will control the support spacing. From manufacturer's data (see Table 5-4), the maximum support spacing, L , for 40 mm PVC pipe is 1.7 m; see Figure C-4, Piping Layout Plan with Support Locations.

Ref. p. 3-17.

$$\Sigma S_L = 0.1 \frac{W L^2}{n Z}$$

Ref. p. 3-25.

$$Z = \frac{\pi}{32} \frac{D_o^4 - D_i^4}{D_o}$$

$$= \frac{\pi}{32} \frac{(50 \text{ mm})^4 - (40 \text{ mm})^4}{(50 \text{ mm})} = 7,245 \text{ mm}^3$$

It is assumed that snow and ice will not occur concurrently and since the ice loading is greater than the snow loading, the sustained loads are equal to the weight of the piping system and the ice.

Ref. p. 3-17.

$$\Sigma S_L = (0.1) \frac{[27.4 \text{ N/m} + 28.2 \text{ N/m}](1.7 \text{ m})^2}{(10^{-3} \text{ m/mm})(7,245 \text{ mm}^3)}$$

$$= 2.26 \text{ MPa}$$

For 40-FES-111, $\Sigma S_L \leq 1.33S_h$; therefore, the system is acceptable for the design stress loading.

Step 3. Stresses are imposed upon the piping system due to thermal expansion and contraction. To ensure that thermoplastic piping systems have sufficient flexibility to prevent these failures, a minimum offset is required between a bend and a restrained anchor. For 40-FES-111, there are a series of Z-shaped arrangements: A-B-C-D, C-D-E-F, E-F-G-H, and G-H-I-J; see Sketch C-12.

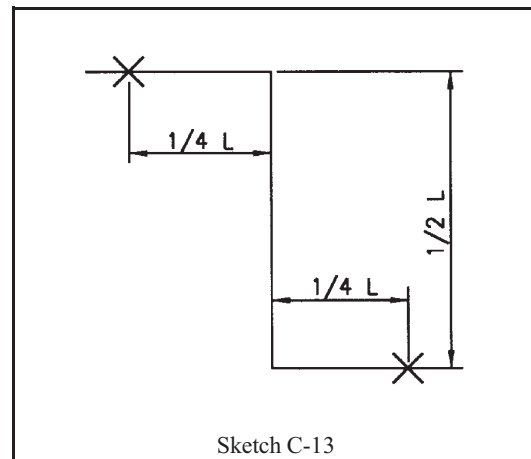

Referencing Sketch C-13, for Z-shapes:

$$L = \frac{1 \text{ m}}{1,000 \text{ mm}} \left(\frac{3 E D_o e}{S} \right)^{0.5}$$

where:

- L = offset pipe length, m
- E = modulus of elasticity = 2,895 MPa
- S = allowable stress = 13.8 MPa
- D_o = outer pipe diameter = 32 mm
- e = thermal expansion coefficient = $2.43 \times 10^{-3} \text{ mm/mm}$

For pipe section A-B-C-D with a length of approximately 3 m:

$$L_{ABCD} = \frac{1 \text{ m}}{1,000 \text{ mm}} \times \left(\frac{3(2,895 \text{ MPa})(50 \text{ mm})[(2.43 \times 10^{-3} \frac{\text{mm}}{\text{mm}})(3,500 \text{ mm})]}{13.8 \text{ MPa}} \right)^{0.5}$$

= 0.52 m, minimum.

Since $\frac{1}{2}$ (B-C) = $\frac{1}{2}$ (3.5 m) > L_{ABCD} , the flexibility of the piping segment is acceptable. The restraints (anchors) should be located at a minimum $\frac{1}{4}$ L = $\frac{1}{4}$ (0.52 m) = 0.13 m from the bends.

For pipe section C-D-E-F with a length of approximately 3 m:

$$L_{CDEF} = \frac{1 \text{ m}}{1,000 \text{ mm}} \times \left(\frac{3(2,895 \text{ MPa})(50 \text{ mm})[(2.43 \times 10^{-3} \frac{\text{mm}}{\text{mm}})(3,000 \text{ mm})]}{13.8 \text{ MPa}} \right)^{0.5}$$

= 0.34 m, minimum.

Since $\frac{1}{2}$ (D-E) = $\frac{1}{2}$ (3 m) > L_{CDEF} , the flexibility of the piping segment is acceptable. The anchors should be located at a minimum $\frac{1}{4}$ L = $\frac{1}{4}$ (0.34 m) = 0.08 m from the bends. That is, a pipe guide should be located at support no. S1006 and another within the existing pipe trench.

For pipe section E-F-G-H with a length of approximately 7.5 m:

$$L_{EFGH} = \frac{1 \text{ m}}{1,000 \text{ mm}} \times$$

$$\left(\frac{3(2,895 \text{ MPa})(50 \text{ mm})[(2.43 \times 10^{-3} \frac{\text{mm}}{\text{mm}})(7,500 \text{ mm})]}{13.8 \text{ MPa}} \right)^{0.5}$$

= 0.75 m, minimum.

Since $\frac{1}{2}$ (F-G) = $\frac{1}{2}$ (7.5 m) > L_{EFGH} , the flexibility of the piping segment is acceptable. The anchors should be located at a minimum $\frac{1}{4}$ L = $\frac{1}{4}$ (0.75 m) = 0.19 m from the bends. That is, a pipe guide should be located at support no. 1016 and a vertical pipe guide established at 0.2 m from BOP on support no. S1036.

For pipe section G-H-I-J with a length of approximately 1.5 m:

$$L_{GHIJ} = \frac{1 \text{ m}}{1,000 \text{ mm}} \times$$

$$\left(\frac{3(2,895 \text{ MPa})(50 \text{ mm})[(2.43 \times 10^{-3} \frac{\text{mm}}{\text{mm}})(1,500 \text{ mm})]}{13.8 \text{ MPa}} \right)^{0.5}$$

= 0.24 m, minimum.

Since $\frac{1}{2}$ (H-I) = $\frac{1}{2}$ (1.5 m) > L_{GHIJ} , the flexibility of the piping segment is acceptable. The anchors should be located at a minimum $\frac{1}{4}$ L = $\frac{1}{4}$ (0.24 m) = 0.06 m from the bends. That is, relocate the vertical pipe guide established on S1036 at 0.20 m BOP down to $\frac{1}{2}$ the vertical run, $\frac{1}{2}$ (2 m) = 1 m BOP. Also locate the support for the solenoid valve at 0.06 m from the bend at I.

I. Line 20-FES-112

Chemical Feed from Ferrous Sulfate Day Tank
to Ferrous Sulfate Controlled Volume Pump

The controlled volume pump has a 20 mm female taper threaded connection. The piping from the pump to the process injection point is supplied by the process unit manufacturer and is 20 mm SAE 100R7 hose. Therefore, 20-FES-112 is selected to be identical to the process hose: 20 mm SAE 100R7 hose (thermoplastic tube, synthetic-fiber reinforcement, thermoplastic cover) with 20 mm male taper threaded end connections, built-in fittings. Minimum hose length is 2 m.

Ensure that the process engineer, or the engineer that is specifying the day tanks, designs the ferrous sulfate day tank with the proper discharge port - 20 mm taper threaded nozzle, female.

Appendix D Index

Numerals before and after colons designate chapters and pages respectively (for example, 4:6 designates page 4-6). Italicized numerals indicate that the subject is illustrated in a figure.

Abrasion, 7:1; 9:1-2
control, 2:6; 4:8-9

Abrasiveness, 3:8

ABS
see Acrylonitrile butadiene styrene pipe

Absorption, 9:1-2

Acrylonitrile butadiene styrene pipe, 5:1, 3, 9-10

AASHTO, 2:9; 5:5

Air relief valves, 11:1, 3, 4, 5

Air vents, 2:11; 8:7

Allowable stress, 2:6; 3:5, 15-17; 4:14, 16

Allowable pressure, maximum, 2:7; 3:2, 4-6; 4:9

Allowance, corrosion-erosion, 3:4-5, 15-16

Aluminum, 3:2; 4:10, 12, 20-21
alloys, 4:20-21

Ambient temperature, 3:17, 28

American National Standards Institute, 2:5; 3:17, 19;
11:1

American Petroleum Institute, 2:5; 4:10

American Society of Mechanical Engineers, 2:5; 3:17, 19;
4:14

American Society for Quality Control, 2:5

American Society for Testing and Materials, 2:5; 3:1; 5:2

American Water Works Association, 2:8-9; 3:19; 4:17;
11:1, 7

Anchors
for fiberglass pipe, 7:4

ANSI
see American National Standards Institute

API
see American Petroleum Institute

ASCE 7, 2:8

ASME Boiler and Pressure Vessel Code

ASME B31, Code for Pressure Piping, 11: 5-6
B31.1, Power Piping, 3:4-5
B31.3, Chemical plant and petroleum refinery piping,
2:8-9; 3:2-3, 15, 17-19; 5:2; 11:6-7

ASME Standards for
cast iron pipe flanges and flanged fittings, 4:14
factory-made wrought steel butt welding fittings, 4:14
pipe flanges and flanged fittings, 4:14
welded and seamless wrought steel pipe, 4:14

ASTM
see American Society for Testing and Materials

Atmospheric vacuum breaker, 11:1, 3

Austenitic stainless steel, 4:18

AWWA
see American Water Works Association

Backflow prevention, 10:1; 11:7-8

Ball Valve, 10:8, 11
V-port, 10:11

Bedding factors, 5:5, 7, 8

Bending, 3:16

Bill of materials, 3:21

Bleed-off of air, 11:1, 3-5

- Bolting, 3:19-21, 23; 9:2-3
Torque, 3:23; 9:4-5
- Bolting Materials, 3:21
- Brass pipe, 4:21
- Brazed joints, 4:10
- Brinell Hardness, 3:1
- Brittle transition temperature, 3:1, 29
- Butterfly valve, 2:15; 10:8, 12, 16-17, 21-22
- Cable leak detection systems, 8:8
- CADD
see Computer-aided drafting design
- Calculations, 2:1
- Carbon steel pipe, 4:17-18; 8:3; 9:1-3
specifications, 4:17
- Category D fluid service, 3:31; 11:6
- Category M fluid service, 11:6
sensitive leak test, 3:31
- Cathodic protection, 1:1; 4:1, 3-4, 6; 9:1; 12:1-2, 3, 4
design, 12:2
impressed current system, 12:3
galvanic protection, 12:3
isolation joints, 4:3; 12:2,4
- Caulked joints, 4:10
- Cavitation, 4:8-9
- Charpy impact test, 3:1
- Check valve, 2:15; 10:9-10, 21
- Chemical resistance; 7:5
- Chlorinated polyvinyl chloride pipe (CPVC), 5:1, 3, 4, 10
support spacing for, 5:7
- Coatings, protective,
for piping, 12:4
for supports, 3:30
- Codes, 2:5-6
organizations, 2:5
- Coefficient of expansion, 2:9
- Component standards, 2:6
- Compression molding, 7:1
- Computer-aided drafting design (CADD), 2:10
- Computer programs
CADD, 2:10
heat tracing, 11:12
pipeline design and analyses, 2:1, 10
pipe networks, 3:4
stress analysis, 3:17
valve selection, 10:20
- Concentration cell, 4:1
- Construction Engineering Research Laboratories,
USACE (CERL), 4:1-2
- Copper and copper alloy pipe, 4:21
support spacing for, 4:10,13
- Corrosion, 2:6; 4:1-9
allowance, 3:4-5, 15-16
coatings, 4:1; 12:4
concentrated cell, 4:1, 3-4, 5
dealloying, 4:1, 8
erosion corrosion, 4:1, 8-9
external, 7:1; 9:1; 12:1
galvanic, 4:1-3
general, 4:1-2
intergranular, 4:1, 6
internal, 4:4, 6, 8-9; 7:1; 9:1; 12:1
microbially induced, 4:9
pitting, 4:1, 4, 6
protection, 4:1, 4, 6; 12:1-4
stress-corrosion cracking, 4:1, 7; 5:1; 8:1; 9:1-2
theory of, 4:1
- Corrosion expert, qualifications, 4:1; 12:1-2

- Corrosion resistance, 3:1, 26; 4:2, 17-18; 5:1-2; 6:2; 7:1;
B:1
- Cost, 3:1, 8; 7:1; 10:13
preliminary for system design, 2:2
- Couplings, 2:15; 9:2; 11:1
Dresser, 11:2
- CPVC
see Chlorinated polyvinyl chloride pipe
- Cracks, 4:7; 8:1
- Critical closure time, 3:6-7
- Critical pressure ratio, 10:17, 19
- Damage, physical, 2:6
- Darcy-Weisbach
equation, 3:8-9
friction factor, 3:8-9, 11, 14
loss coefficients, 3:8-9, 13
- Dead weight, 2:7
- Deflection, 2:6; 3:25-26; 5:5
lag factor, 5:8
- Deformation, 3:1; 8:2; 12:4
- Design
bases, 2:2, 5, 10
conditions, 2:5
criteria, 2:1,6
factors, 9:1-2
flow rate, 3:7-14
pressure, 2:5,7
external, 2:7
internal, 2:7
pressure integrity, 3:5, 7, 14-17
specifications, 2:1
system descriptions, 2:1
temperature, 2:5, 7
- Diaphragm valve, 10:8, 21-22
- Differential pressure, 10:13, 14-15, 17, 20
- Dimensional standards, 7:1
- Dissimilar materials, interconnection of, 2:6; 4:2-3; 9:2
- Dissolved gases, 3:3
- Double check valve backflow preventer, 11:7-8
- Double containment piping, 8:1-8, 9:1
regulatory basis for, 8:1
standards, 8:1
- Drain, 2:11; 8:6-7; 11:5
- Drain valve, 11:5
- Drawing generation, 2:1-2, 3-4, 10, 12-13
- Dresser couplings, 11:2
- Drop-weight impact test, 3:1
- Ductile iron pipe, 4:17
- Ductility, 3:1
- Dynamic loads, 2:7
- Elasticity, 3:1, 6; 8:6
- Elastomeric piping, 6:1-5
connections, 6:4
corrosion resistance, 6:2-3
liners, 9:7
standards, 6:2
temperature limits, 6:1
- Elastomeric seals, 7:2
- Elastomeric seats, 10:1, 6
- Electrical isolation, 12:2, 4
- Elongation, 3:1; 4:14
- Environmental factors, 2:6
- Environmental stress cracking, 5:2; 8:1; 9:1
- Equivalent length of piping, 3:8-9, 12

Erosion, 2:6; 3:15; 10:13 Erosion corrosion, 4:1,

8-9 Excess pressure, due to water hammer, 3:5-7

Excursions, pressure/temperature, 2:7; 3:3, 5-7

Expansion, 2:8; 11:9

fluid, 11:7

thermal, 2:8, 10; 4:14; 7:4-5; 8:2, 4, 6; 9:3

Expansion-contraction, 2:10; 7:4; 8:2, 6

Expansion joints, 4:15; 5:3; 7:4; 8:2, 6; 9:3; 11:11

ball, 11:9-10

bellows, 4:15; 5:3; 11:1, 9-10

corrugated, 11:1, 10

slip, 4:15; 5:3; 11:9

Expansion Loop, 2:12; 4:15-17; 5:3-4; 7:1, 4-5; 8:2, 5, 6

Fatigue, 3:15, 18-19

Fiberglass, 7:1; 10:8

Filament winding, 7:1-2

Fittings, 2:6; 4:14

cast bronze/brass, 4:21

flanged, 4:17-20

threaded, 4:17-20

malleable iron, 4:17

nickel alloy, 4:20

steel, 4:17-19

thermoplastic, 5:2, 9-10

welding, 4:15, 17-20

butt welding, 4:14, 18

socket welding, 4:14, 18

Flammable fluids, 3:2

Flange, 3:2, 19-20; 7:2; 10:7

facings, 3:20

materials, 3:19

ratings, 3:2

selection and limitations, 3:19-20

thermoset, 7:2

Flanged joints, 2:15; 3:2, 19-20; 4:14; 9:2

Flexible connections, 2:15, 12; 3:26; 11:1

Flexibility, 2:12, 15; 4:15; 7:1; 8:2, 6

Flow, 3:7-14; 9:1

characteristic for valves, 10:1, 2, 3

coefficient, 3:9; 10:13, 15, 16, 17, 20

drainage, 8:7

flushing, 8:7

rate, 3:7; 10:1

resistance coefficient, 3:9

velocity, 3:8

Flushing, system, 3:30-31; 8:7

Friction factor-turbulent flow, 3:8, 9, 10

Friction loss, 3:8

FRP

see Fiberglass reinforced plastic

Galvanic action, dissimilar joints, 4:2-3

Galvanic protection for supports, 3:29

Galvanic series, 4:2

Galvanizing, 4:17

Gaskets, 3:19-22; 9:2

Gate valve, 10:11, 21

Glass, glass-lined pipe, 9:7

Glass pipe, 8:3

Globe valve, 10:10-11, 16, 21-22

Hangers, 2:9, 3:26

Hardness, 3:1

Hardy Cross method, 3:14

Hastalloy, 3:2; 4:19

- Hazardous applications, 10:10
- Hazardous substance, 8:1, 8
- Hazardous wastes, 9:1
- Hazen-Williams formula, 3:19
 - coefficient, 3:9-10
 - limitations, 3:14
- HDPE, 5:11
- Head loss, 3:8
- Heat-tracing, 2:10; 8:6; 9:1, 3; 11:12
 - design consideration, 2:10; 8:6
- Hydraulic conditions, backpressure, 3:2
- Hydraulic diameter, 8:6-7
- Hydraulic loads, 2:9
- Hydraulic snubber, 10:9
- Hydrostatic testing, 2:11; 3:30
 - test pressure, 3:30
- Ice load, 2:8
- Identification of piping, 3:23-24
- Impact
 - failure, 7:1
 - strength, 3:1
 - test, 3:1
- Inconel, 4:19-20
- Installation
 - above ground, 5:5; 6:5; 8:6; 9:3; 12:1
 - below ground, 5:5, 9; 6:5; 7:4; 8:6; 9:3; 12:1
 - leak detection systems, 8:8
 - reduced pressure backflow prevention assemblies, 11: 7-8
 - supports, 3:25; 9:3
- Insulation
 - electrical isolation, 3:29; 12:2, 4
 - thermal, 2:10; 3:25-27; 8:6; 9:3; 11:10
- Insulation thickness, 3:25
- Intergranular attack, 4:6
- Internal piping, 1:1
- International Organization for Standardization, 2:5; 5:2
- ISO
 - see International Organization for Standardization
- Isolation
 - joints, 12:2,4
 - of supports for reinforced polyester pipe, 7:3
 - valves, 10:1, 11, 13
- Isometric drawings, 2:1, 14
- Joining, thickness allowance, 3:15
- Joints, piping, 4:10, 14
 - brazed, 4:10
 - caulked, 4:10
 - compression, 4:10
 - compression couplings, 11:1
 - coupled, 11:1
 - DIP, 4:14
 - flanged, 2:15; 3:2, 19-20; 4:14; 7:2; 9:1; 10:7
 - flared, 4:10
 - gasketed, 3:19-22
 - grooved, 3:15, 4:20
 - inspection, 3:29
 - mechanical, 4:18, 20; 9:2
 - metallic, applicable codes, 4:14
 - screwed, 10:7
 - soldered, 4:10, 14
 - swagging, 3:15
 - thermoplastic, 5:2-3
 - thermoset, 7:1-2
 - threaded, 3:15; 4:10, 14, 20; 5:9
 - welded, 3:29; 4:10, 14; 10:7
- Laminar flow, 3:8, 10
- LDPE, 5:11
- Leak detection, 8:1, 8
- Leak-testing, 3:29-31
 - methods, 3:29-31

- planning, 3:29
- records, 3:29-30
- sensitive leak test, 3:31

- Leakage
 - expansion joints, 11:9
 - valve seats, 10:7

- Length equivalents, 3:8, 11

- Lift check valve, 10:9-10

- Liner, pipe, 7:1; 9:1-2
 - liquid applied, 9:6
 - material properties, 9:6

- Lined piping, 9:1-7
 - elastomeric/rubber, 9:7
 - glass, 9:8
 - nickel, 9:8
 - PFA, 9:3, 7
 - PP, 9:2-7
 - PTFE, 9:2-7
 - PVDC, 9:3-7
 - PVDF, 9:2-7

- Live load, 2:7-10

- Loading conditions, 2:6-10
 - dead load, 2:7
 - live load, 2:7-10
 - occasional load, 2:7-10
 - sustained load, 2:7; 3:19

- Malleable iron, 4:17

- Manning factors, 3:9-10, 14

- Manufacturer Standardization Society of the Valve and Fitting Industry (MSS), 2:5; 3:28, 29; 4:14

- Martensitic stainless steel pipe, 4:18-19

- Material combinations
 - double containment piping, 8:1-3
 - valve seat, 10:4-5

- Material selection guidelines, B:1

- MDPE, 5:11

- Mechanical joints, 4:18, 20

- Minor loss coefficients, 3:8, 12

- Modulus of elasticity, 3:1; 7:1

- Modulus of soil reaction, 5:9

- Monel, 3:2; 4:19

- Moody diagram, 3:8, 10
 - Reynolds number, 3:8, 10

- MSS
 - see Manufacturer Standardization Society of the Valve and Fitting Industry

- National Fire Protection Association, 11:12

- National Institute of Standards and Technology (NIST), 2:5

- NFPA
 - see National Fire Protection Association

- Nickel and nickel alloys, 4:10-11, 19-20
 - liner, 9:7

- NIST
 - see National Institute of Standards and Technology

- Nominal pipe size, 1:2

- Nominal thickness, 1:2

- NPS
 - see Nominal pipe size

- Operators, valve
 - electric, 10:8-9
 - hydraulic, 10:8-9
 - manual, 10:8
 - pneumatic, 10:8-9, 21
 - schedule, 10:20, 22

- Over pressure protection, 3:4-5

- Piping and instrumentation diagrams (P&ID), 2:1-2, 4, 9; 4:14-15; 5:2; 10:13

Permeability, 9:1-2

Personnel protection, 8:7

PFD see Process flow diagram

Pinch valve, 10:12

Pipe

acrylonitrile butadiene styrene, 5:1, 3, 9-10
 aluminum, 3:2; 4:10, 12, 20-21
 brass, 4:21
 carbon steel, 4:17-18; 8:3; 9:1-3
 chlorinated polyvinyl chloride, 5:1, 3, 4, 7, 10
 copper, 4:10, 13, 21
 ductile iron, 4:17
 ductility, 3:1
 fiberglass, 7:1
 glass, 8:3
 glass-lined, 9:7
 joints, 3:15; 4:10, 14; 5:2-3; 7:1, 4
 identification, 3:23-24
 liners, 7:1; 9:1-7
 material selection, 3:1-2
 nickel, 4:10-11, 19-20
 polyethylene, 5:1, 5, 10-11
 polypropylene, 5:1, 3, 10-11
 polyvinyl chloride, 5:1, 3-4, 6, 9
 pressure, 2:7; 3:2-7
 red brass, 4:21
 steel
 carbon, 4:9-10, 17-18; 8:3; 9:1-3
 stainless, 3:2; 4:9-10, 18-19
 strength, 3:1
 stress, 2:1
 allowable, 2:6; 3:5, 15-17; 4:14, 16
 code limits, 2:6
 combined longitudinal, 3:17, 19; 4:16; 8:2, 6
 external pressure, 3:15
 internal pressure, 3:15-17
 supports, 2:1, 9-10, 15; 3:17, 23-28, 29, 20; 7:3-4; 8:6
 drawings, 2:1
 types, 3:29
 thermal expansion, 2:7-8, 10; 4:14; 7:4-5; 8:2, 4, 6;
 9:3
 thermoplastic, 5:1-11
 thermoset
 reinforced epoxy, 7:1-5
 reinforced furan, 3:2; 7:1-2, 4-5
 reinforced polyester, 7:1-5

reinforced vinyl ester, 7:1-2, 4-5
 sizing, 3:1, 7-14; 5:2; 8:6-7
 sizing criteria, 3:8
 standard sizes, 1:1-2; 3:16
 tolerances, 3:15-16
 toughness, 3:1
 wall thickness, 2:6-7; 3:5, 14-17; 7:4

Piping

accessibility, 2:11
 codes and standards, 2:5-6
 double containment piping, 8:1-8; 9:1
 feedwater, 3:3-7
 flexibility, 2:10, 12
 heat tracing, 8:6; 9:1, 3; 11:12
 instrumentation diagram (P&ID), and, 2:1-2, 4, 10;
 4:14-15; 5:2; 10:13
 insulation, thermal, 2:10; 3:25-27; 8:6; 9:3; 11:10
 interferences, 2:10
 layout considerations, 2:2, 10, 13-14, 15; 3:17
 material selection, 3:1-2
 metallic, 4:1-21; 8:3
 network, 3:8, 14
 physical sketches, 2:2
 pump, 2:10, 15; 3:3-5
 rack, 2:9; 3:27
 relief valve, 3:4-5, 16-17, 29; 11:5-6
 specifications, 2:1
 supports, 2:1, 9-10, 15; 3:17, 23-29; 7:3-4; 8:6
 drawings, 2:1
 system, 1:1
 thermoplastic pipe and fittings, 5:1-11; 8:3
 thermoset piping and fittings, 7:1-7; 8:3
 vents and drains, 3:29
 wall thickness, 2:6-7; 3:5, 14-17; 7:4

P&IDs

see Piping and instrumentation diagrams

Piping components, 2:1-2, 6; 3:2-3, 19

Piping fatigue, 3:15, 18-19

Piping system design, 2:1-15
 sizing criteria, 3:8

Plant layout, 2:2, 10, 12-14, 15; 3:17

Plasticization, 5:1

- Plug valve, 10:12
 - Pneumatic testing, 3:30-31
 - design pressure, 3:31
- Polyester fiberglass pipe, 7:3-5
- Polyethylene (PE), 5:1, 5, 10-11
- Polypropylene (PP), 5:1, 3, 10-11
 - liner, 9:2, 6
- Polytetrafluoroethylene (PTFE), 5:1, 9
 - liner, 9:2-3, 6-7
 - valve packing, 10:8
- Polyvinyl chloride (PVC), 5:1, 3-4, 6, 9
 - supports spacing for, 5:6
- Polyvinylidene fluoride (PVDF), 5:1, 10-11
 - supports spacing for, 5:6
 - liner, 9:2-3, 6-7
- Positioner, for valve, 10:9, 21-22
- PP
 - see Polypropylene
- Pre-design survey, 2:2,5; 12:2
- Pressure, 3:2-7; 9:1
 - class, 3:19-20
 - design, 3:2-4
 - drop, 3:7-8; 10:1, 13, 14-15; 11:8
 - head, 3:8
 - integrity, 3:1, 14-17, 19
 - internal, 2:7; 3:2-3, 7, 17; 7:4
 - maximum steady state, 3:2
 - rating, 3:5, 20; 5:2; 7:5; 10:1
 - surges, 7:1
 - tests, 3:29-31
 - transients, 2:7; 3:3-8; 4:9
 - wave, 3:5-7
- Pressure, maximum allowable, 2:7; 3:2, 4; 4:9
- Pressure relief devices, 11:5-7
 - for double containment piping, 8:7
 - for pneumatic testing, 3:30
- Pressure-temperature rating, 3:3, 19
- Pressure variation, transients, 2:7; 3:3-7; 4:9
- Pressure wave, 3:5-7
- Probe leak detection system, 8:8
- Process control, 2:1-2, 4
- Process flow diagrams (PFD), 2:1-2, 3; 4:14-15; 5:2; 7:4
- Protective coatings
 - for piping, 4:1; 12:4
 - for supports, 3:29
- PTFE
 - see Polytetrafluoroethylene
- Pump
 - installation piping, 2:10, 15
 - system curves, 10:13-14
- PVC
 - see Polyvinyl chloride
- PVDF
 - see Polyvinylidene fluoride
- Qualification
 - of welders, 3:29
 - of welding procedures, 3:29
- Quality, 2:1
- Rack piping, 2:10; 3:27
- Reduced pressure backflow preventer, 11:7-8
- Reduction of area, 3:1
- Reinforcement, 7:1
- Relief valves, 3:4-5, 16-17, 29; 11:5-6
- Resins, 7:1
- Restrained design, 8:2,6

- Reynolds number, 3:8, 10, 13; 10:13, 17, 18
- RMA
see Rubber Manufacturers Association
- Rockwell hardness, 3:1
- Rotary shaft valve, 10:8-9, 21-22
- Roughness, 3:8-9; 7:1
- Route selection, 2:10-11
- Rubber Manufacturers Association, 6:2
- Rupture disk, 11:6-7
- SAE
see Society of Automotive Engineers
- Safety codes, 2:7
- Sample connections, 11:5
- Sample piping, 11:5
- Saran, 9:6
- SD see System description
- SDR
see Standard dimension ratio
- Seismic
codes, 2:6,8-9
loads, 2:8-9
zones, 2:8
- Selection criteria
piping materials, 3:1-2
valves, 10:1-3
- Self-contained automatic valve, 10:12-13
- Sensitive leak test, 3:31
- Sizing
air and vacuum relief devices, 11:3
drain, 8:7
piping, 3:7-14
- rupture discs, 11:6-7
thermoplastic pipe, 5:2
valves, 10: 13, 14-15, 16-17, 18-19, 20
- Slurry, 9:2; 10:12
- Snow load, 2:8
- Society of Automotive Engineers, 6:1-2
- Soil conditions, 2:5; 12:2
modulus of soil reaction, 5:8
- Specifications, 2:1
- Stainless steels, 3:2
austenitic, 4:18
ferritic, 4:18-19
martensitic, 4:18-19
- Standard dimension ratio (SDR), 3:6
- Standards, 2:5-6; 7:1-2
dimensional, 7:1, 5
- Static mixers, 11:8-9
pressure loss, 11:8
- Steel
carbon, 4:17-18; 8:3; 9:1-3
stainless, 3:2; 4:18-19
austenitic, 4:18
ferritic, 4:18
martensitic, 4:18
- Stop check valve, 10:9-10
- Storage tank piping, 8:1
- Strain, 3:1, 18
- Strength
tensile, 3:1; 7:1
yield, 3:1, 29-30; 8:1
- Stress
allowable, 2:6; 3:5, 15-17; 4:14, 16
combined longitudinal, 3:17, 19; 4:16; 8:2, 6
cracking, 8:1; 9:1-2
design, 2:5; 9:1-2

- external loads, 3:15
 - pressure, 3:3, 5; 8:2, 6
 - relieving, 4:7
 - thermal, 4:14-16; 5:3; 7:4; 8:2
- Stress analysis, 3:1, 17-19
- for seismic excitation, 3:19
 - for thermal expansion, 3:18
 - for weight, 3:17
- Structural attachments, 2:9; 3:25, 27
- Structural integrity, 3:25; 7:3
- Supports, piping, 2:1, 8-9, 11; 3:17, 23-28, 29, 30; 7:3-4; 8:6
- adjustment, 3:30
 - ambient systems, 3:17, 29
 - attachments piping, 3:29
 - attachments to building, 2:9; 12:4
 - coatings, protective, 3:30
 - cold spring, 3:30
 - cold systems, 3:27
 - design of (general), 2:9-10; 3:23
 - dynamic loadings, 2:9
 - hot systems, 3:27
 - installation of, 3:23
 - interstitial, 8:6
 - load determination, 3:25-26
 - loading considerations, 2:9-10; 4:14
 - locating supports, 2:9-10; 3:23, 25
 - materials, special considerations, 4:10
 - pump interconnection, 2:9-10, 15
 - rod hangers, 2:9; 3:26, 29
 - rollers, 3:26-27, 29
 - saddles, 3:27, 29
 - seismic loadings, 2:8-9
 - selection, of, 3:23, 28, 29, 30
 - spacing of supports, 2:9; 3:23, 25-26; 4:9-10; 5:4; 7:3-4
 - spring hangers, 3:26-27, 29; 5:4
 - temporary, 3:29-30
 - valves and fittings, 3:15; 10:9
 - vibration dampers, 2:9
- Supports and support spacing
- for double containment piping, 8:6
 - for elastomeric piping, 6:5
 - for metallic piping, 4:9-14
- for thermoplastic piping, 5:5-7
 - for thermoset pipe, 7:3-4
- Surge control
- electrical, 12:4
 - pressure, 2:9
- Survey, Predesign, 2:2, 5; 12:2
- Swing check valve, 10:9-10, 21
- System, description, 2:1
- Temperature, 9:1; 10:1
- brittle fracture, 3:29; 7:1
 - design, 3:2
 - limits,
 - for fiberglass pipe, 7:1-2, 5
 - for thermoplastic liners, 9:1
 - transition, 3:1, 29
- Thermal analysis
- allowable offset span in, 7:4
 - free thermal, 7:4
 - thermal modes, 7:4
- Thermal expansion, 2:7, 9; 4:14; 7:4-5; 8:2, 4, 6; 9:3
- Thermoplastic piping, 5:1-11
- available products, 5:1
 - dimensioning systems, 5:2
 - jointing methods, 5:2-3
 - pressure rating, 5:2
- Thermoplastics, 5:1-11
- liners, 9:1-2
 - spacers, 9:2
- Thermoset pipe, 7:1-6
- Thermosetting resins, 7:1
- Tilting disc check valve, 10:9-10
- Tolerances, 3:15-16
- Toughness, 3:1
- Turbulent flow, 3:8, 10

Ultimate tensile strength, 3:1

Uniform Building Code
seismic loads, 2:8

UPS, 8:8

Vacuum breaker, 11:1, 3, 4, 5
location, 11:5

Valve

air relief, 11:1, 3, 4, 5
angle, 10:11, 16
back-flow prevention, 10:1
ball, 10:8, 11
bleed-off of air, 11:1, 3-5
blow-off, 11:5
butterfly, 2:15; 10:8, 12, 16-17, 21-22
check, 2:15; 10:9-10, 21
control, 10:13-20
diaphragm, 10:8, 21-22
drain, 11:5
gate, 10:11, 21
globe, 10:10-12, 16, 21-22
isolation, 10:1, 11, 13
location design, 2:15
maintenance of, 10:11
pinch, 10:12
plug, 10:13
pressure rating, 10:1
pressure relief valves, 3:4-5; 11:5-6
recovery factor, 10:13, 15, 16-17, 20
regulating, 10:1
relief, 10:1
selection, 10:20
standards, 2:6
stem leakage, 10:7
supports, 3:15; 10:9

Valve location, 2:15

Vent, 2:11; 9:1,3
extension, 9:3

Vibration, 2:9; 5:5

Vinyl-ester fiberglass pipe, 7:4-5

Visual leak detection system, 8:8

Wafer valve, 10:7-8, 11-12

WHAMO, 3:6

Wall relaxation, 8:2

Wall thickness, 2:6-7; 3:5, 14-17; 7:4
corrosion allowance, 3:15-16

Water hammer, 2:8, 15; 3:5-8, 17; 7:1; 11:7

Weight, system, 2:7

Welders, qualification of, 3:29

Welding
procedure specification, 3:29
tests, 3:29

Welds, examinations of, 3:29

Wheel load, 2:9-10; 7:4

Wind load, 2:8

Yield strength, 3:1, 29-30; 8:1